

Note: De-pressurize and vent system prior to riser tube installation.

- 1** Identify the manifold branch to be converted for use with liquid cylinders:

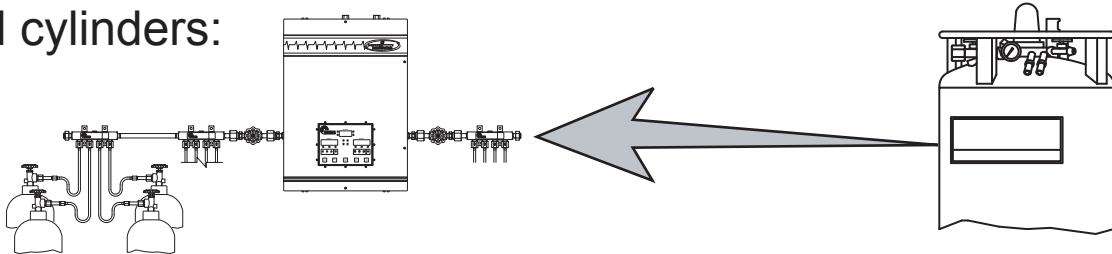

- 2** Remove the 1/2" NPT pipe plug on top of the last manifold block on the branch:

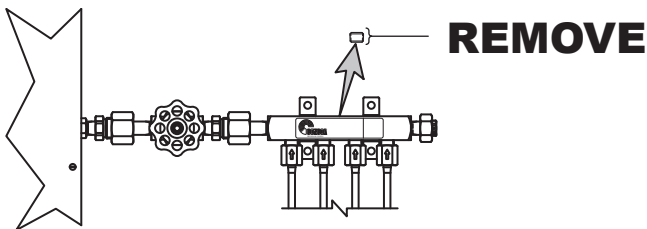

- 3** Clean PTFE tape out of the open port taking care to avoid tape falling into the manifold:

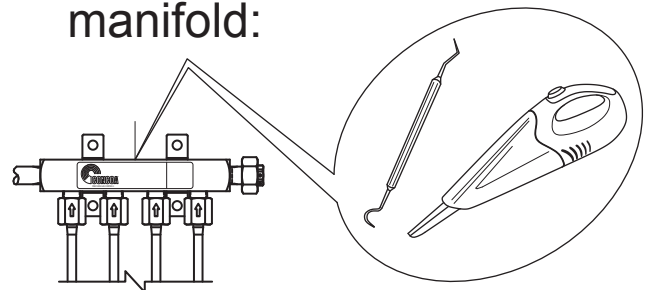

- 4** Check that appropriate inlet pressure appears on tube tag, and apply PTFE tape to NPT thread of riser tube:

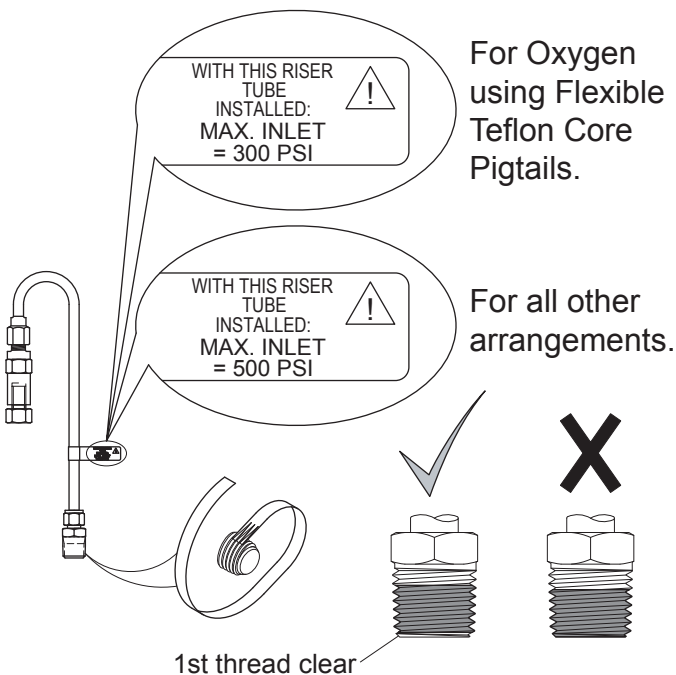

- 5** Fasten riser tube to manifold block:

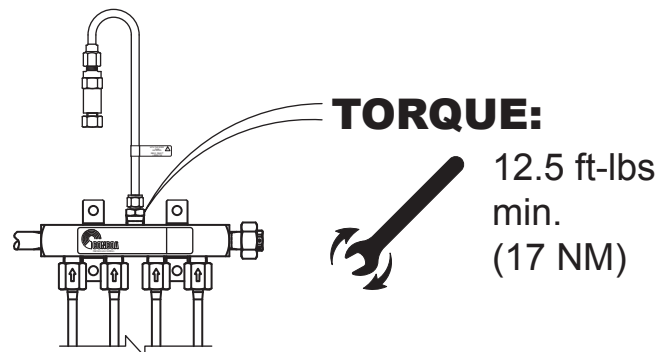

- 6** Leak test all models regardless of max. inlet shown on the tube tag using 500 psi test pressure.

