



Installation & Operation Instructions of 5651560 Series 65MM &150MM Glass Tube Flowmeters

Standard glass tube flowmeters are available in various ranges and configurations. The meters have 65 millimeter and 150 millimeter reference scales, and are supplied with flow curves for air. At your request, flow curves for other gases or liquids can be supplied, and direct read scales are available on a special order basis.

UNPACKING

We have taken precautions to prevent damage during shipment. However, if you receive this meter damaged, report it to the carrier immediately. Before installing, check to assure that you have the model and flow range you require.

INSTALLATION

This meter is designed to be panel mounted, or to be mounted on a leveling tripod base or mounted to a regulator (use 565 0001 Brass or 565 0002, 316 SS). It must be mounted vertically, unless otherwise specified, and in a manner which minimizes both external vibrations and internal flow variations. Panel mounting requires 2 holes with 19/32" diameters, drilled with centers as shown in Figure 1. The meter is held onto the panel with 2 pal nuts which are supplied with the meter. A leveling tripod (base) is available for free-standing use.

The meter is supplied with 1/8" FNPT non-rotating fittings. Use Teflon tape to ease installation, and to provide a better seal. When installing 1/8" MNPT fittings into the meter, torque only to 60 in-lbs maximum. Place the appropriate size wrench on the hex to prevent the inlet/outlet fitting from rotating, causing damage to fittings and meter back plate. Special care should be taken that connections to the unit's inlet/outlet fittings do not overly restrict the liquid or gas being metered. This could result in a reduced flow volume, preventing the meter from reaching its maximum flowrate; also, internal pressures could be affected, causing inaccurate flow readings.

Leak check prior to use. If metering fluids contain contaminants, install a filter upstream to reduce the amount of containment reaching the meter. On start-up, slowly purge any air/gas trapped in the meter. To obtain the correct flow reading, read the center of the ball float.

MAINTENANCE

Occasional cleaning may be required if dirt appears in the flow tube, or if float movement becomes restricted. The lens and tube assemblies can be disassembled for cleaning or parts replacement without removing it from the process line. Clean the tube and float with a mild liquid detergent and a soft brush or swab. **Rinse/flush** with clean water, and dry thoroughly with clean, dry air, or Nitrogen (Caution: handle with care, or tube will break).

DISASSEMBLY

Bleed off any pressure in the flowmeter, and turn off the control valve (if unit has one). With a 5/32" Allen wrench, turn the jackscrew counter clockwise until it reaches a stop. Move the lens cover up and down to break the seal, and then pull out horizontally. While supporting the tube, carefully remove the lens caps from the top and bottom of the tube. Remove the glass tube from the lens/shield. Using extreme care, remove in the following order: Top float stop, float, and bottom float stop. Be careful not to lose the float, and note which is the top and which is the bottom float stop. To remove a control valve, turn counter clockwise with a 1/2" open-end wrench. See maintenance for cleaning.

REASSEMBLY

Check that all parts are clean and dry. Install parts as follows: bottom float stop from bottom of glass tube. Ball float, and top float stop are to be installed from the top of the glass tube. Position the float stops. Install the bottom lens cap over the bottom of the tube. Install the bottom lens cap over the bottom of the tube. Insert the tube in the lens/shield and install the top lens cap. Check the top and bottom gaskets and replace, if necessary. Carefully slide the tube assembly back into the meter, making sure that it is properly positioned with scale facing forward. Tighten the jackscrew by turning clockwise with the Allen wrench until the gaskets make contact with the tube. Carefully tighten a maximum of 1/2-3/4 turn more or torque to 3-4 in-lbs to achieve positive seal. Do not over tighten. Replace the control valve by turning clockwise with a 1/2" open-end wrench. Close the valve before start-up. Slowly pressurize the meter. Check for leaks before resuming operation.

If you have any questions, feel free to call CONCOA Customer Service 1-800-225-0473.

CAUTION

THIS FLOWMETER IS DESIGNED FOR USE WITH NONHAZARDOUS FLUIDS AT PRESSURES UP TO 200 PSIG (13.8 BAR), AND TEMPERATURES UP TO 93° C (200°F). DO NOT USE HAZARDOUS FLUIDS, AND DO NOT EXCEED TEMPERATURE OR PRESSURE LIMITS. USE OF HAZARDOUS FLUIDS, OR EXCEEDING PRESSURE AND TEMPERATURE LIMITS MAY CAUSE FAILURE, WHICH COULD RESULT IN INJURY.

SPECIFICATIONS		
ACCURACY:	+/-5% F.S. 65 MM +/-3% F.S. 150 MM	
FLOATS:	BLACK GLASS, SAPPHIRE, STAINLESS STEEL, TUNGSTEN CARBIDE & TANTALUM	
FRAME BACKPLATE:	ALUMINUM	
PRESSURE:	200 PSIG MAX/13.8 BAR	
TEMPERATURE:	200 °F/93 °C MAX	
TUBE:	BOROSILICATE GLASS	
END BLOCKS	ALUMINUM	W/ BUNA "N"
STD. SEALS	BRASS	W/ BUNA "N"
& FITTINGS:	STAINLESS STEEL	W/ VITON "V"

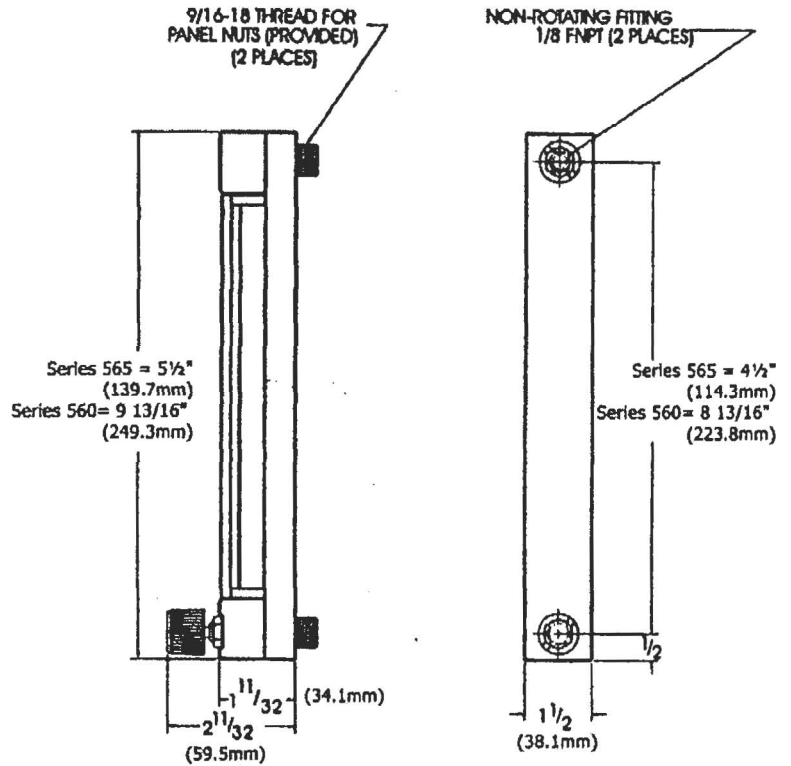
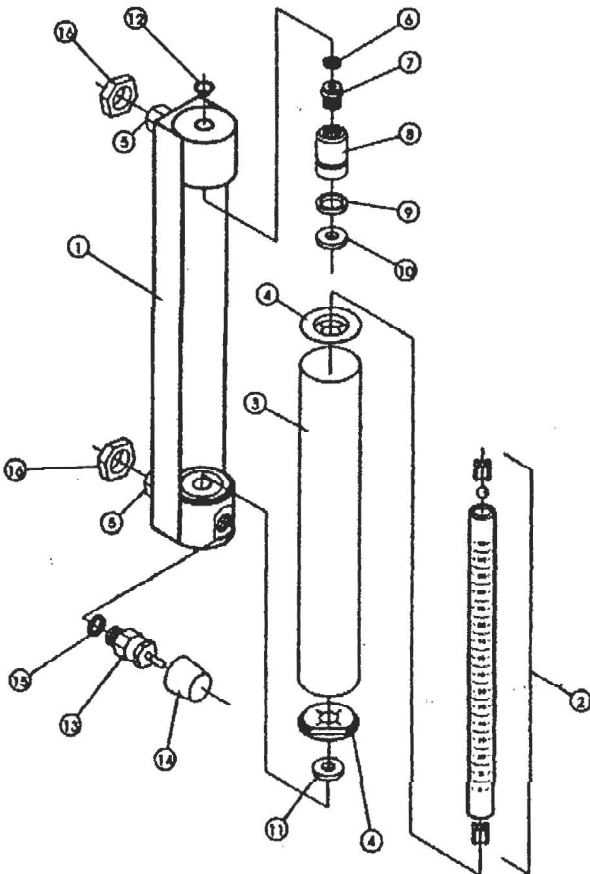

FIGURE 1



ITEM	DESCRIPTION
1	FRAME ASSEMBLY
2	TUBE ASSEMBLY
3	LENS
4	LENS END CAP
5	FITTING
6	JACKSCREW O-RING 009
7	JACKSCREW
8	JACK PLUG
9	JACK PLUG O-RING 014
10	TOP GASKET
11	BOTTOM GASKET
12	RETAINING CUP
13	OPTIONAL VALVE
14	VALVE KNOB
15	VALVE O-RING 903
16	PANELNUTS

CONTINUED PRODUCT IMPROVEMENT MAY RESULT IN SPECIFICATION REVISIONS

WHEN ORDERING PARTS PLEASE INCLUDE PART DESCRIPTION, ITEM NUMBER & TYPE OF MATERIAL REQUIRED.