



536/537 Series Autoswitch Systems

For use with
Liquid Cylinders and
High Pressure Gases
in High Purity Applications

INSTALLATION AND OPERATION INSTRUCTIONS

Before Installing or Operating, Read and Comply with These Instructions

Controls Corporation of America
1501 Harpers Road Virginia Beach, VA 23454
To Order Call 1-800-225-0473 or 757-422-8330 • Fax 757-422-3125
www.concoa.com

May 2003
Supersedes October 2002

THIS PAGE INTENTIONALLY LEFT BLANK

DESCRIPTION OF PRODUCT

The 536/537 Series autoswitches are automatic switchover systems designed to provide a continuous supply of high purity gas. These units may be configured with or without the connections to connect to both high pressure and liquid cylinders. The primary bank (left side) of the autoswitch system is configured for use with liquid cylinders (pressure up to 600 PSI). The reserve bank (right side) is configured for high pressure cylinders filled up to 3000 PSI. The standard autoswitch system will maintain a regulated line pressure within the values shown in the table below:

MODEL	RANGE
536 2XXX	0-50 PSI (0-3.5 BAR)
537 2XXX	0-50 PSI (0-3.5 BAR)
536 3XXX	0-100 PSI (0-7 BAR)
536 3XXX	0-100 PSI (0-7 BAR)

The continuous working inlet pressure on the primary bank (liquid cylinder) must be above 140 PSI for the system to operate properly. When the primary bank falls below this value, gas will be pulled from the reserve side.

These Models can be configured to be used in conjunction with an optional Remote Alarm. They cannot be connected directly to AC line voltage. In addition to a Power Indicator light, the autoswitch is equipped with LED status lights to indicate the condition of the gas cylinders. A green indicator light signifies a “Normal” condition while a red light indicates an “Alarm” (Gas cylinder empty) condition. The autoswitch system includes a separate connector that mates to the connector on the bottom of the unit. This will be needed to construct an interface cable between the Remote Alarm and the autoswitch. Please refer to the ADI Manual that is included with the Remote Alarm for wiring and operating instructions.

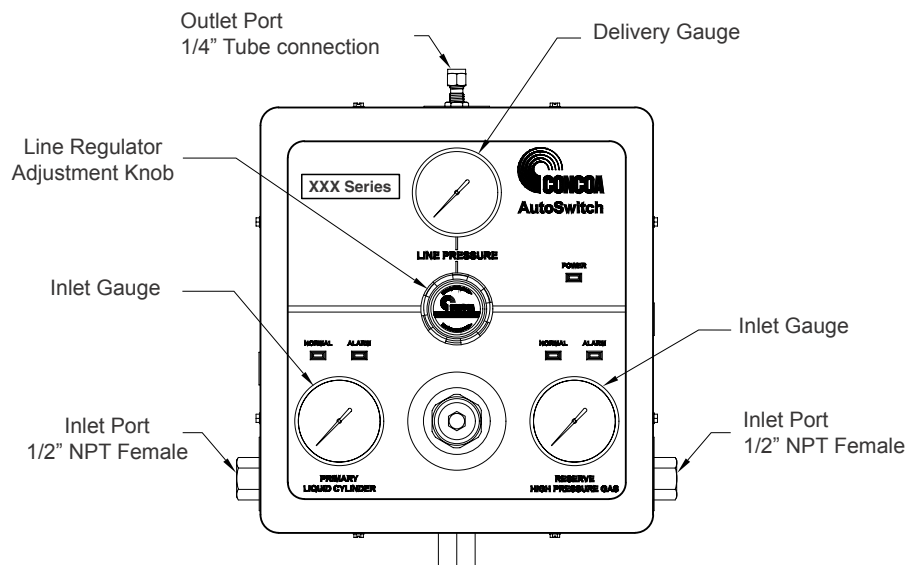

Figure 1

INTENDED USE OF PRODUCT

The brass 536 Series autoswitch system is intended for use in high purity, non-corrosive gas applications. The 537 stainless steel autoswitch is for use in ultra-high purity applications. Please note the safety information shown in the later sections.

USER RESPONSIBILITY

The User of this equipment should follow all installation and operation instructions when using this equipment. It is recommended that the user review all safety precautions listed in the safety section of this manual.

This equipment must be checked periodically. Improperly working equipment should not be used. Broken, worn, distorted, contaminated, or missing components should be replaced immediately.

CUSTOMER ASSISTANCE

In the event of equipment failure, call the CONCOA Customer Assistance Line: 1-800-225-0473. Please be prepared to provide the model number and serial number of the equipment involved, in addition to some details regarding its application. This would include inlet and outlet pressures, flow rate, environmental conditions, and gas service.

SAFETY

Carefully read and comply with these instructions before installing or operating any high pressure gas manifold. These manifolds are designed, manufactured, and tested to conform to industry standards for safety for high pressure gas manifolds for maximum inlet pressure of 3000 pounds per square inch (200 bar), working pressure on the reserve (right) side. The primary (left) side is rated up to 600 PSI (40 bar).

Always observe the following safety practices:

- √ Store cylinders with valve caps screwed on, and cylinders chained to a supporting wall or column.
- √ Handle cylinders carefully and only with valve caps screwed on. The cap will prevent the cylinder valve from breaking off at the top of the cylinder if the cylinder is accidentally dropped or falls over. The cap also protects the cylinder valve from damage to screw threads, which could cause leaky connections.
- √ Always open valves slowly when high-pressure gases are being used. Open valves all the way.
- √ Always be sure that a cylinder contains the correct gas before connecting it to any manifold.
- √ Always leak-test any manifold or distribution pipeline before using.
- √ Always be sure that the gas in a pipeline is the correct gas for the intended use.
- √ Always install a blind gland and nut or piping plug on any manifold inlet fitting if no cylinder is connected to the fitting before opening any cylinder valve which is already connected to the manifold.
- √ Always close all cylinder valves before disconnecting cylinders from a manifold.
- √ Always remove all empty cylinders from a manifold before connecting full cylinders.
- √ Always test cylinders to be sure they are full before connecting to a manifold.
- √ NOTE: Use of Teflon® lined pigtailed for oxygen installations is not recommended unless they are equipped with a Distance Volume Piece (DVP). Components in the manifold system can create a dead end passage. The combination of a dead end passage coupled with a rapid pressurization may lead to adiabatic compression of the contained oxygen and subsequent failure of the pigtail by ignition.
- √ All gas distribution piping systems must meet appropriate industrial standards for the intended service, and must be thoroughly cleaned before using.
- √ Keep all cylinders away from any source of high temperature (not over 120° F, 50° C) or possible fire hazards. High-pressure gas contained in a closed cylinder becomes increasingly dangerous when exposed to high temperature because pressure increases and the strength of the cylinder decreases.
- √ No smoking should be permitted near oxygen nitrous oxide, flammable gases and flammable mixtures and in area where cylinders are stored.
- √ Where oxygen or nitrous oxide is used, the manifold and cylinders must be kept clean. No oil, grease, or combustible substances should come in contact with oxygen or nitrous oxide storage or handling equipment. Such materials in contact with oxygen or nitrous oxide are readily ignitable and when ignited, will burn intensely.
- √ Never lift gas cylinders with a magnetic lifting device.
- √ Never use an open flame when leak testing.

Comply with all safety rules and precautions of the following:

1. American National Standards Institute standard Z49.1 or Safety in Welding and Cutting, American Welding Society, 2501 NW Seventh Street, Miami, FL 33125.
2. N.F.P.A. Standard 51, Oxygen-Fuel Gas Systems for Welding and Cutting, N.F.P.A., 470 Atlantic Avenue, Boston, MA 02210.
3. N.F.P.A. Standard 51B, Cutting and Welding Processes, (see Address in #2)
4. CONCOA Publication ADE 872, Safety Precautions in Welding and Cutting.
5. Local ordinances.
6. O.S.H.A.
7. C.G.A. Pamphlet C-4, American National Standard Method of Marking Portable Compressed Gas Containers to Identify the Material Contained.*
8. C.G.A. Pamphlet G-4, Oxygen-Information on the properties, manufacture, transportation, storage, handling, and use of oxygen.
9. C.G.A. Pamphlet G-4.1, Equipment Cleaned for Oxygen Service.
10. C.G.A. Pamphlet C-4.4, Industrial Practices for Gaseous Oxygen Transmission and Distribution Piping Systems.
11. C.G.A. Pamphlet G-5, Hydrogen - Information on the properties, manufacture, transportation, storage, handling, and use of hydrogen.
12. C.G.A. Pamphlet G-6, Carbon Dioxide - Information on the properties, manufacture, transportation, storage, handling, and use of carbon dioxide.
13. C.G.A. Pamphlet G-6.1, Standard for Low Pressure Carbon Dioxide Systems at Consumer Sites.

INSTALLATION

The site chosen for the installation of the system shall be level, well ventilated, and at a safe distance from sources of flames, sparks, and excessive heat. The system should not be placed in an area that may subject it to damage from passing trucks, cranes, or other heavy machines. Any oxygen system must not be installed under shafting, belting, or other places where oil can drip on it. Refer to the Manifold ADI for Manifold installation instructions.

- a. Be sure to consider all factors when selecting materials.
- b. Do not use oil or grease on fittings.
- c. Be sure that all fittings are secure and leak tight. Teflon tape should be used on pipe threads. See Figure 6.
- d. Relief valve: The purpose of the relief valve is to protect the autoswitch system and its components only (Figure 2). If there is pressure sensitive equipment downstream of the autoswitch system, it is recommended that an appropriately sized relief valve be installed in the line to protect this equipment.
- e. Purge devices: These devices can be purchased as accessories. Purge devices are used to remove toxic, corrosive, or flammable gases from the customer's system to a safe discharge area. This is particularly helpful when an internal problem occurs (such as regulator malfunction).

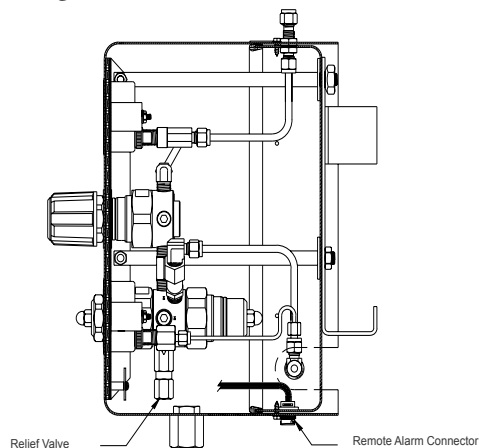

Figure 2

WALL MOUNTING

Follow Compressed Gas Association, OSHA and all applicable local codes. Manifolds should not be placed in locations where the temperature will exceed 102°F (49°C) or fall below 0°F (-18°C). Manifolds installed in open locations should be protected from weather conditions. During winter, protect the manifold from ice and snow. In summer, shade the manifold and cylinders from continuous exposure to direct sunlight. Always leave access to the manifold for cylinder replacement.

1. Determine and mark the vertical center line for installation of the AutoSwitch Console. (Figure 3).
2. Measure from the floor 72" in height* of this center line. This height will place the manifold header approximately 66" from the floor. Using a level, mark a horizontal line at this point extending approximately 10 inches to the left and right of center.
3. Remove the mounting bracket from the rear of the AutoSwitch Console by removing the retaining nuts at the bottom of the mounting bracket (Figure 5). Place the upper edge of the bracket cross-member on the horizontal line so that it is centered with the vertical line. Holding the bracket with the slotted extensions away from the wall, mark the location of the two mounting bolts (Figure 4).
4. Using appropriate hardware based on wall construction, anchor the mounting bracket to the wall (Figure 4).
5. Place the autoswitch system so that the mounting bracket slots align with the shoulder nuts. With the autoswitch box hanging on the shoulder nuts, align the retaining bolts so that they protrude through the bracket. Replace the mounting nuts that were removed in step 3.

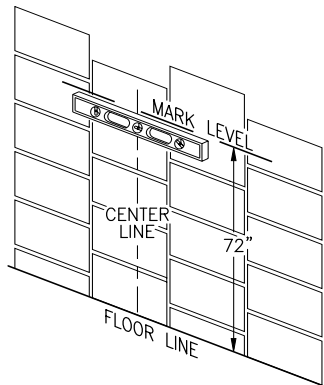

Figure 3 - Center-line Mark

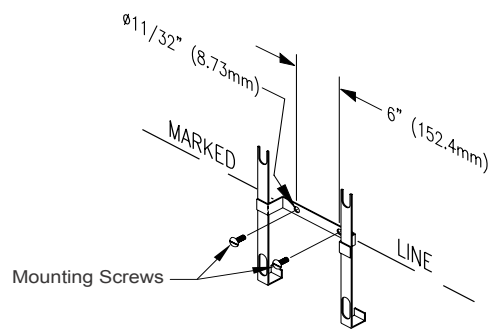

Figure 4 - Mounting Bracket

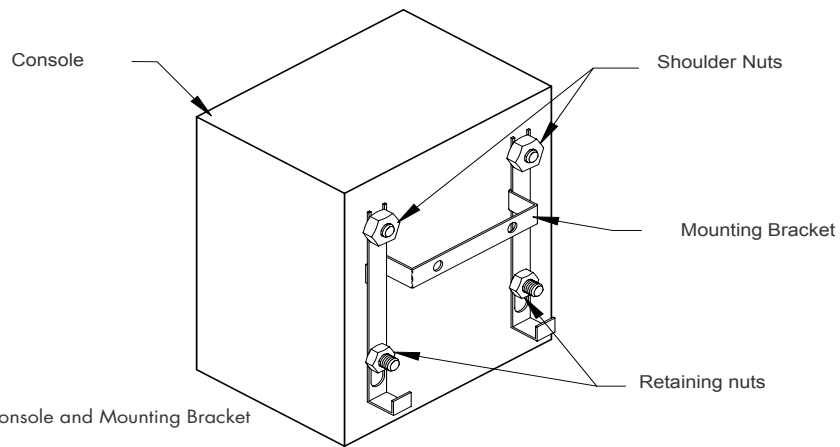

Figure 5 - Console and Mounting Bracket

INLET AND OUTLET CONNECTIONS

General:

Use an open-end wrench, not a pipe wrench, to install accessories to the autoswitch system. **ALWAYS hold the bulkhead fitting with a wrench when installing the accessories to the autoswitch system. Do not allow the bulkhead fitting to turn; otherwise, connections inside the box may be loosened.** NPT connections require the use of Teflon tape on the threads to make a gas tight seal. (See Figure 6.) On stainless steel connections, the thread sealant helps prevent the connections from galling together when tightening or loosening. CONCOA uses Teflon tape on all of its NPT connections. Follow these rules when using Teflon tape.

Inspect the NPT threads and if necessary, clean the fitting to remove any dirt or thread sealant that remains on the threads. Start the Teflon tape on the second thread as shown in Figure 6; make sure the tape does not overlap the end of the fitting. As the tape is wrapped in the direction of the thread spiral, pull tightly on the end of tape so that the tape conforms to the threads. Wrap the tape around the threads twice. Cut off the excess tape and press the end firmly into the threads.

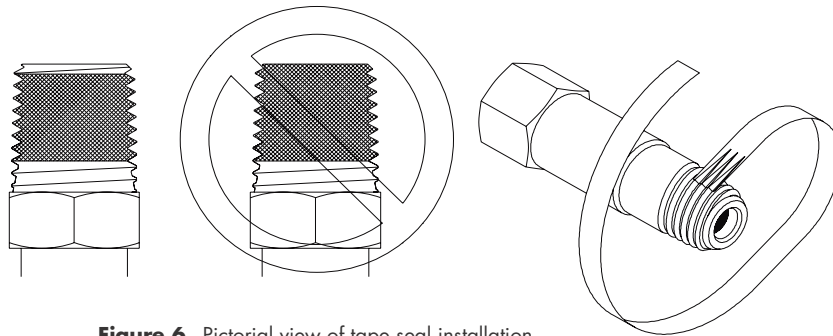

Figure 6 - Pictorial view of tape seal installation

Installing the inlet connection:

Warning: The left bank of the autoswitch system has a maximum working pressure of 600 PSI. Do not install high pressure cylinders to the left bank of the autoswitch system.

When using a Maniflex system:

The 1/2 male NPT end of the manifold connector will need to be installed in the inlet port of the autoswitch. The other end of the manifold connector will be connected to the starter block of the 528 series Maniflex system. Please follow the instructions provided with the Maniflex system when connecting and operating the manifold system.

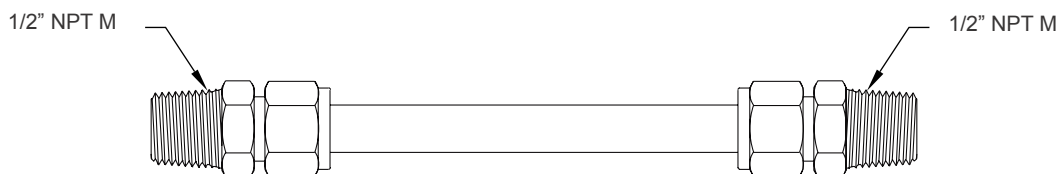

Figure 7 - Manifold connector for the Maniflex system

For Non-manifold Use:

If purchased with pigtails, the male 1/2 NPT end of the elbows is installed into the inlet ports of the switchover system. Install the male 1/4 NPT end of the pigtails into the 1/4 NPT ports of the diaphragm valve. The connection available at the other end of the pigtail will depend on how the system was purchased. If the pigtail does not have a cylinder connection installed, there will be a female 1/4 NPT on the end of the pigtail. The female 1/4 NPT pigtail end will connect to the user's system. If configured with a CGA connection or foreign inlet connection, the connection will be specific to the particular cylinder of gas to be used. Some connections do require the use of a gasket. Please note that the material of the gasket must also be compatible with the type of gas being used. Be familiar with the type of connection being used, and its proper procedures for installation.

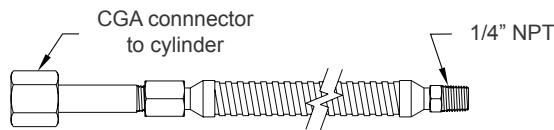

Figure 8 - Pigtail

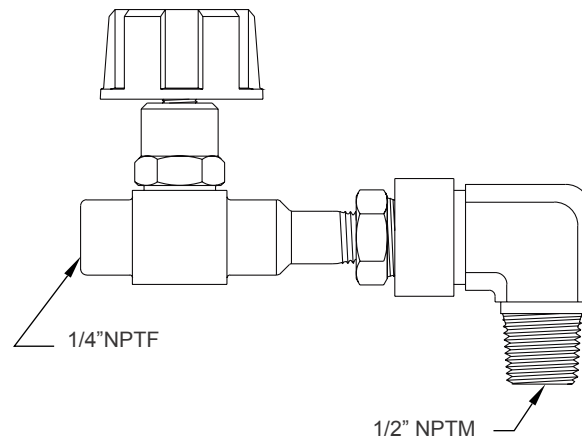

Figure 9 - Diaphragm valve with 1/2" NPT street elbow

Connecting to a cylinder:

1. Before removing the cylinder cap, move the cylinder of gas to the work site:
 - a. Secure cylinder to the floor, wall, or bench with appropriate chain, strap, or stand to prevent toppling.
 - b. Remove the cylinder cap.
 - c. Be sure the cylinder valve is tightly closed (clockwise)
 - d. Remove the cylinder valve plug, if any.
 - e. Inspect the cylinder valve and threads for damage or contamination.
2. Secure the cylinder connection to the cylinder in the following manner:
 - a. Do not force. Tightening the nut onto the cylinder connection should be easy. If it is not, the connection may be wrong for the type of gas being used.
 - b. Left-hand threads are used on some cylinder connections. A notch in the middle of the hex nut typically indicates a left-hand thread.
 - c. Gaskets are used on some inlet connections. Be sure the gasket is in good shape. Do not over-tighten to avoid squashing the gasket into the gas line. Keep extra gaskets on hand.
 - d. Never use oil or grease on regulator or cylinder fittings, as it may contaminate pure gases, or create a fire hazard.

Installing the Outlet Connection:

The autoswitch system has the outlet connection at the top of the box. The connection is a 1/4" tube connection. Connect tubing to the autoswitch that is compatible with the application and is capable of handling the pressure required.

Pressurizing the system for the first time (non-manifold use):

Before system startup, it is recommended that all systems be pressure tested, leak tested, and purged with an inert gas such as nitrogen. To accomplish this with connections other than a CGA 580, it will be necessary to use an adapter. The recommended use of an adapter is for temporary use only, for system start up and checks. Adapters should never be used on a permanent basis.

1. Wear safety glasses and gloves.
2. Be sure that both ends of all hoses or pigtails are secured before pressurizing. Turn the line regulator knob counterclockwise until the knob stops turning.
3. When first pressurizing, do not stand in front of or contact the switchover system. Slowly open the cylinder valve. Observe the high pressure gauge for a rise in pressure up to full cylinder pressure.
4. Keep the hand wheel or wrench on the open cylinder valve at all times, to allow prompt emergency shut-off.
5. Inspect all connections for leaks and fix any leaks. A leak detection solution may be applied to the connections (if compatible with the application) which indicates leaks by bubbling. To further check for leaks, or if the leak detection solution can not be used, close the cylinder valve for a period of time (recommended 24 hours), and observe the high pressure gauge for a drop in pressure. If so indicated, recheck the CGA connection and all other high-pressure port connections. Never attempt to fix a leak under pressure. If leaks are detected, depressurize the system and retighten the connection. Begin again at step 3.

WARNING: While CONCOA assembles the autoswitch system components to exacting leak-tight standards, the customer should also inspect for any loosening of internal parts that may occur in shipping or installation by completing the pressure decay test detailed above. If all external leaks have been found, corrected, and the system still indicates a leak, disassemble the front cover from the autoswitch after removing the eight screws shown in Figure 10. Check for leaks on the system's fittings as described above.

6. Slowly turn the line regulator knob clockwise. This will increase the pressure of the line. Adjust to the desired working pressure and again check for leaks using the methods described above.

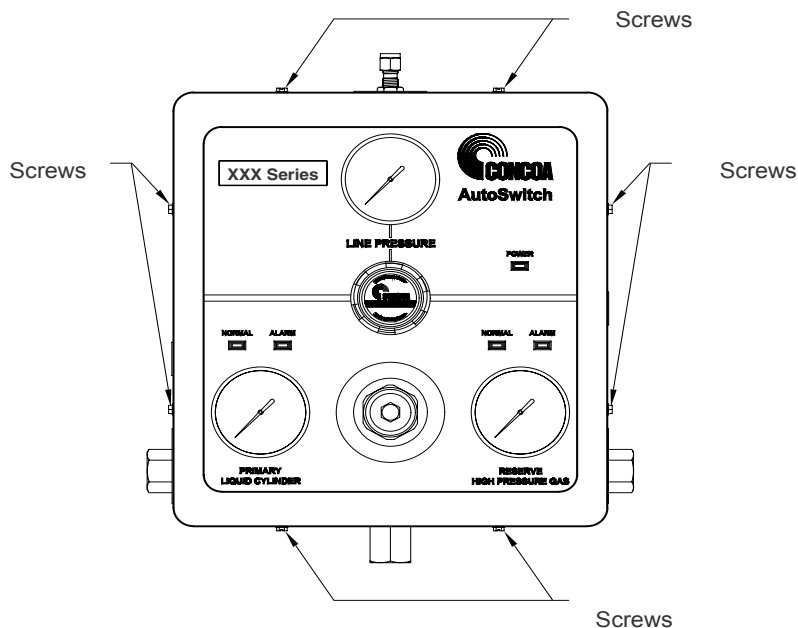

Figure 10

OPERATION

As the gas in the primary side (liquid cylinders) is depleted, there will not be a drop in gas pressure on the left gauge until the cylinders are empty. When the inlet pressure drops to the pressure setting of the reserve side regulator, flow will begin from the reserve cylinder. The inlet pressure on the primary side will stabilize at 130-140 PSI. This is called a changeover. At this point, the gas pressure on the reserve side will drop. This indicates that it is time to change the liquid cylinders on the primary side. Before removing the cylinder, be sure to close the cylinder valve and any other valves that connect the cylinder to the system. Remove the depleted cylinder(s) and replace with a full cylinder(s). Note: While changing cylinders on one side, there will be no interruption in flow.

WARNING: After several changeover cycles, it is possible that the reserve cylinder may not have sufficient reserve capacity. Periodically check the pressure of the reserve high pressure cylinders. Maintain enough gas in the high pressure cylinders so that when a changeover occurs, the system will not run out of gas before the liquid cylinders are replaced.

Adjusting the alarm set point, does not affect the switchover point of the autoswitch. The alarm is used to provide an audible and visual warning that a changeover is about to occur. If the nearly depleted cylinders are changed when the alarm LED's illuminate, the cylinders will not be as empty as if the actual changeover had occurred. Slide the red tab seen on the inlet gauge to adjust the alarm set point. The lowering of the alarm set point pressure may cause the alarm not to work properly. When adjustments are made, check the function of the system. Pressurize the system and shut off the inlet pressure to both sides. Allow the inlet pressure to decrease by allowing a small flow (50 CFH). Observe both inlet gauges. When the left bank is low (below the set point on the gauge), the red LED will illuminate. Make sure the left, red LED illuminates before the pressure on the opposite side starts to decrease. Allow the system inlet pressure to decrease further until the right, red LED illuminates. This should happen before both inlet pressures start falling together.

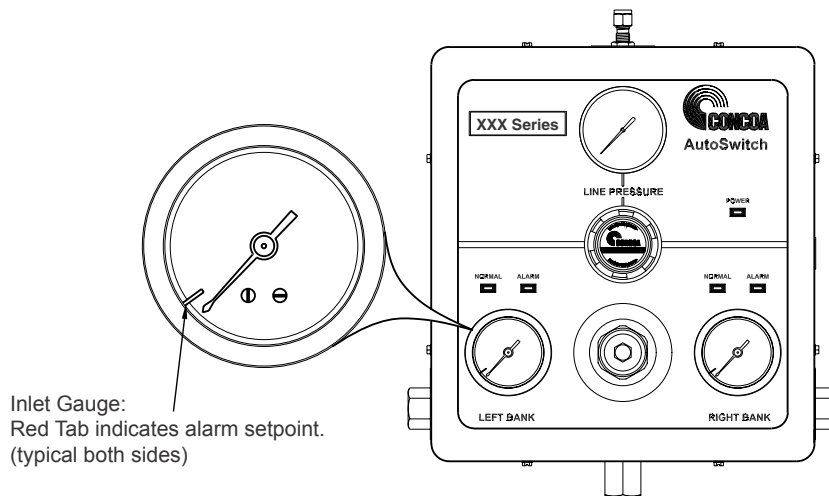

Figure 11

MAINTENANCE

On regular intervals, the system should be checked for leaks and proper function (see trouble shooting). Any leaks in the system should be corrected immediately. The pigtail check valve should also be checked for leaks when a depleted cylinder is removed. Note: the system inlet and pigtail should be pressurized when checking for leaks. At no time should the preset regulator's pressure settings be changed.

TROUBLESHOOTING

Symptom	Cause
<ol style="list-style-type: none"> 1. Gas leakage at the line regulator outlet when the adjusting knob of the line regulator is completely backed out. 2. With no flow through the system (downstream valves closed and adjusting screw in) line pressure steadily increases above set pressure. 3. Gas leakage from spring case (adjusting screw/knob end of regulator). 4. Gas leakage from any joint. 5. Excessive drop in working pressure with regulator flowing gas. 6. Gas leakage from relief valve. 7. Gas leakage from any gauge. 8. Gauge does not return to zero when not under gas pressure. 9. Gauge does not consistently repeat the same reading. 10. The system makes a noise or hums. 	<ol style="list-style-type: none"> 1. Regulator(s) have malfunctioned. Replace or repair.
<ol style="list-style-type: none"> 1. Inlet gauges not reading pressure. 	<ol style="list-style-type: none"> 1. Check that the valves on the cylinders are opened. 2. If using a manifold system, check that the valve on the manifold is opened.
<ol style="list-style-type: none"> 1. Switchover system seems to be using gas from the primary and reserve cylinders (pressure is decreasing on both inlet gauges at the same time.) 	<ol style="list-style-type: none"> 1. Observe the inlet pressure. It may be necessary to do this during times of the heaviest use. If the inlet pressure is <u>less</u> than the values listed below, replace the high pressure cylinders. <ul style="list-style-type: none"> 536 2XXX 140PSI (10 BAR) 536 3XXX 140PSI (10 BAR) 537 2XXX 140PSI (10 BAR) 537 3XXX 140PSI (10 BAR) <p>If the inlet pressure increases significantly when the system is not in use, then the system is over-withdrawing the liquid cylinders. Additional capacity may be added to the system to prevent this.</p>
<ol style="list-style-type: none"> 1. Power light is not on. 	<ol style="list-style-type: none"> 1. Check that connector to remote alarm is properly plugged into the autoswitch and the alarm. 2. Check that the remote alarm is powered on. 3. Check that cable between autoswitch and remote alarm is wired correctly.
<ol style="list-style-type: none"> 1. Status lights are not on. 	<ol style="list-style-type: none"> 1. Check that connector to remote alarm is properly plugged into the autoswitch and the alarm. 2. Check that the remote alarm is powered on. 3. Check that cable between autoswitch and remote alarm is wired correctly.

TROUBLESHOOTING (Continued)

Symptom	Cause
1. Green status light(s) is lit when the pressure is below the set point on the gauges. 2. Red status light(s) is lit when the pressure is above the set point on the gauges.	1. Cable to remote alarm wired incorrectly. Follow instructions in remote alarm ADI to correct problem.
1. With full tank pressure, red alarm light(s) is on.	1. Check that the setpoint on the gauges is set properly.

SERVICE

A Unit that is not functioning properly should not be used and should be returned to CONCOA for service. A Return Material Authorization (RMA) number must be issued for any product returned to CONCOA for service. Please contact a Customer Service Representative at 1-800-225-0473 to receive this number. You will be asked to provide:

1. Model Number
2. Gas Service
3. Inlet pressure and type of gas supply
4. Outlet pressure
5. Approximate gas usage

When shipping product back to CONCOA for repair the following steps should be followed:

1. Package the product sufficiently to prevent damage. If possible return product in its original packing.
2. Include RMA number on the outside of the carton.
3. Ship prepaid.
4. Include a written description of the problem you encountered with the product inside the package.
5. Include a statement of the gas service the product was used in.
6. Purge all equipment before shipping to protect the transporter and service personnel. Purging is especially important if the equipment has been in hazardous or corrosive gas service.

THIS PAGE INTENTIONALLY LEFT BLANK

THIS PAGE INTENTIONALLY LEFT BLANK

Warranty Information

This equipment is sold by CONTROLS CORPORATION OF AMERICA under the warranties set forth in the following paragraphs. Such warranties are extended only with respect to the purchase of this equipment directly from CONTROLS CORPORATION OF AMERICA or its Authorized Distributors as new merchandise and are extended to the first Buyer thereof other than for the purpose of resale.

For a period of one (1) year from the date of original delivery (90 days in corrosive service) to Buyer or to Buyer's order, this equipment is warranted to be free from functional defects in materials and workmanship and to conform to the description of this equipment contained in this manual and any accompanying labels and/or inserts, provided that the same is properly operated under conditions of normal use and that regular periodic maintenance and service is performed or replacements made in accordance with the instructions provided. The foregoing warranties shall not apply if the equipment has been repaired: other than by CONTROLS CORPORATION OF AMERICA or a designated service facility or in accordance with written instructions provided by CONTROLS CORPORATION OF AMERICA, or altered by anyone other than CONTROLS CORPORATION OF AMERICA, or if the equipment has been subject to abuse, misuse, negligence or accident.

CONTROLS CORPORATION OF AMERICA's sole and exclusive obligation and Buyer's sole and exclusive remedy under the above warranties is limited to repairing or replacing, free of charge, at CONTROLS CORPORATION OF AMERICA's option, the equipment or part, which is reported to its Authorized Distributor from whom purchased, and which if so advised, is returned with a statement of the observed deficiency, and proof of purchase of equipment or part not later than seven (7) days after the expiration date of the applicable warranty, to the nearest designated service facility during normal business hours, transportation charges prepaid, and which upon examination, is found not to comply with the above warranties. Return trip transportation charges for the equipment or part shall be paid by Buyer.

CONTROLS CORPORATION OF AMERICA SHALL NOT BE OTHERWISE LIABLE FOR ANY DAMAGES INCLUDING BUT NOT LIMITED TO: INCIDENTAL DAMAGES, CONSEQUENTIAL DAMAGES, OR SPECIAL DAMAGES, WHETHER SUCH DAMAGES RESULT FROM NEGLIGENCE, BREACH OF WARRANTY OR OTHERWISE.

THERE ARE NO EXPRESS OR IMPLIED WARRANTIES WHICH EXTEND BEYOND THE WARRANTIES HEREINABOVE SET FORTH. CONTROLS CORPORATION OF AMERICA MAKES NO WARRANTY OF MERCHANTABILITY OR FITNESS FOR A PARTICULAR PURPOSE WITH RESPECT TO THE EQUIPMENT OR PARTS THEREOF.

ADI #3198C



Controls Corporation of America
1501 Harpers Road Virginia Beach, VA 23454
To Order Call 1-800-225-0473 or 757-422-8330 • Fax 757-422-3125
www.concoa.com