



623 Series Dome Load Regulators

INSTALLATION AND OPERATION INSTRUCTIONS

This Equipment is intended to be installed and operated by trained personnel.

Before Installing or Operating, Read and Comply with These Instructions

Controls Corporation of America
1501 Harpers Road • Virginia Beach, VA 23454
To Order Call 1-800-225-0473 or 757-422-8330 • Fax 757-422-3125
www.concoa.com

Warning: An appropriately sized pressure relief device downstream of the regulator should be installed in your system to prevent damage to equipment and/or injury to personnel should an internal failure of the regulator occur.

Warning: Maximum allowable working pressure indicated on product labeling is for the regulator only. Ratings for peripherals/accessories may be less than the pressure indicated on the product label. Do not exceed the pressure ratings of the attached peripherals/accessories and the regulator's maximum allowable working pressure. Please contact your gas supplier for more information.

Warning: for regulators with tube fittings, select the appropriate tubing. Use seamless tubing with the proper consideration given to wall thickness and material. Please contact your gas supplier for more information.

USER RESPONSIBILITY

This equipment will perform in conformity with the description contained in this manual and accompanying labels and/or inserts when installed, operated, maintained, and repaired in accordance with the instructions provided. This equipment must be checked periodically. Improperly working equipment should not be used. Parts that are broken, missing, worn, distorted or contaminated, should be replaced immediately. CONCOA recommends that a telephone or written request for service advice be made to CONCOA Customer Service in Virginia Beach, Virginia, PHONE: 1-800-225-0473, FAX: 1-757-422-3125, or E-MAIL: e-mail@concoa.com.

This equipment or any of its parts should not be altered without prior written approval by CONCOA. The user of this equipment shall have the sole responsibility for any malfunction that results from improper use, faulty maintenance, damage, improper repair, or alteration by anyone other than CONCOA or a service facility designated by CONCOA.

CUSTOMER SERVICE

In the event of equipment failure, call CONCOA Customer Service. Please be prepared to provide the model number and serial number of the equipment involved, in addition to some details regarding its application.

Things to consider before removing the regulator from the box....

1. Know the properties and special handling requirements of the gas being used. Many gases are quite dangerous (flammable, toxic, corrosive, simple asphyxiant, or oxidizers). Equipment failure or misuse may lead to problems such as a release of gas through the relief valve or regulator diaphragm. Proper safety measures should be established to handle these and other component failures.
2. Be sure that the assembly purchased is suitable for the gas and type of service intended. The system label provides the following information:
 - a. Model number
 - b. Serial number
 - c. Maximum inlet pressure

Be sure that the equipment received conforms to the order specifications. The user is responsible for selecting equipment compatible

with the gas in use, and conditions of pressure, temperature, flow, etc. Selection information can be found in CONCOA technical data sheets. In addition, CONCOA representatives are trained to aid in the selection process.

3. Inspect the assembly upon receipt to be sure that there is no damage or contamination. Pay particular attention to connecting threads. While CONCOA assembles system components to exacting leak-tight standards, the customer should also inspect for any loosening of parts that may occur in shipping or installation. Loose parts may be dangerously propelled from an assembly. If there are adverse signs (leakage or other malfunction), return the assembly to the supplier. While it is advised that soiled regulators be returned for cleaning, simple external dust or grease may be removed by a clean cloth and if required with aqueous detergent suitable for the application. If there are signs of internal contamination, return to the supplier.
4. Before system start-up, it is recommended that all systems be pressure tested, leak tested, and purged with an inert gas such as nitrogen.

If the regulator includes gas specific inlet connections, their purpose is to prevent usage on the wrong gases. Adaptation or alteration for use on other gases can be dangerous and is not recommended.

GENERAL SAFETY PRACTICES

Specific procedures for the safe use of this equipment are listed below. Refer to CONCOA ADE 872, latest revision, Safe Practices in Welding and Cutting.

- a. Never use the regulator for gases other than those specified. Never use an oxygen regulator in any other gas service.
- b. All connections to the regulator must be clean before connecting to a pressure source. Ordinary dirt can be wiped off with clean, lint-free cloth. Remove oil or grease from external surfaces of the regulator and metal connecting part.
- c. Do not allow oil, oil-bearing materials, or other combustibles which ignite readily in the presence of oxygen, to come in contact with oxygen regulators. While it is advised that soiled regulators be returned for cleaning, simple external dust or grease may be removed by a clean cloth and if required with aqueous

- detergent suitable for the application. If there are signs of internal contamination, return to the supplier.
- d. Use oxygen regulator only with equipment suitable for and used only for oxygen service. If equipment is ever contaminated in handling or used for any other service it must be thoroughly cleaned by qualified personnel to prevent explosion and/or fire before it is placed back into oxygen service.
 - e. Never pressurize a regulator that has loose or damaged parts or is in questionable condition. Never loosen a connection or attempt to remove a part until gas pressure has been relieved. Under pressure, gas can dangerously propel a loose part.
 - f. The regulator is not equipped with a relief valve. Provide a relief valve or other positive overpressure protective device in any system where there is possibility of exceeding the allowable pressure of the regulator or other equipment.
 - g. Never discharge fuel gas near welding or cutting work, sparks, flame, or other source of ignition.
 - h. Check the regulator and ALL connections for external leaks after installation, periodically thereafter, and for external and seat leaks after any service in which parts or connections were loosened. Check for leaks by applying a leak detection solution to all connections. Use O₂ compatible leak detection solution for O₂ service.

Comply with precautions listed in C.G.A. Pamphlet P-1, Safe Handling of Compressed Gases in Containers.

Consult the cylinder distributor for the proper use of cylinders and for any restrictions on their use (such as flow rate and temperature requirements).

Never use an open flame when leak testing.

Always open valves slowly when high-pressure gases are being used.

Always be sure that a cylinder contains the correct gas before connecting it to any regulator.

Always leak-test any manifold or distribution pipeline before using.

Always be sure that the gas in the system is the correct gas for the intended use.

For the United States, some applicable safety rules and precautions are listed below:

1. American National Standards Institute standard Z49.1, Safety in Welding and Cutting, American Welding Society, 2501 NW Seventh Street, Miami, Florida 33125
2. N.F.P.A. Standard 51, Oxygen-Fuel Gas systems for Welding and Cutting, N.F.P.A., 470 Atlantic Avenue, Boston, Massachusetts 02210
3. N.F.P.A. Standard 51B, Cutting and Welding Processes (same address as #2).
4. CONCOA publication ADE 872, Safety Precautions in Welding and Cutting.
5. Local Ordinances
6. O.S.H.A. Standard 29 CFR
7. C.G.A. Pamphlet C-4, American National Standard Method of Marking Portable Compressed Gas Containers to Identify the Material Contained.
8. C.G.A. Pamphlet G-4, Oxygen – Information on the properties, manufacture, transportation, storage, handling, and use of oxygen.
9. C.G.A. Pamphlet G-4.1, Equipment Cleaned for oxygen service.
10. C.G.A. Pamphlet G-4.4, Industrial Practices for Gaseous Oxygen Transmission and Distribution Piping Systems.
11. C.G.A. Pamphlet G-5, Hydrogen – Information on the properties, manufacture, transportation, storage, handling, and use of hydrogen.
12. C.G.A. Pamphlet G-6, Carbon Dioxide – Information on the properties, manufacture, transportation, storage, handling, and use of carbon dioxide.
13. C.G.A. Pamphlet G-6.1, Standard for Low Pressure Carbon Dioxide Systems at Consumer Sites.
14. C.G.A. Pamphlet P-1, Safe Handling of Compressed Gases in Containers.
15. C.G.A. Safety Bulletin SB-2, Oxygen Deficient Atmospheres.

*C.G.A. pamphlets can be obtained from the Compressed Gas Association, 1235 Jefferson Davis Highway, Arlington, VA 22202-3239, (703) 979-0900. Publications: (703) 979-4341. Fax: (703) 979-0134.

INTRODUCTION

Scope

This manual provides installation, operation, and service information for the CONCOA Dome-Loaded regulators.

Description

The regulators are designed to control and reduce gas pressure, from high inlet pressure to a suitable working pressure as required by the equipment in use.

They are pilot-operated gas-loaded regulators with an internal bleed. Each has a control system (usually including a pilot regulator) which introduces gas into the dome to increase the regulated pressure.

CAUTION

If the working pressure rating of any downstream equipment is less than the maximum delivery pressure of the regulator, a pressure relief device such as a relief valve or bursting disc must be installed downstream of the regulator. The setting of such a device must be below the working pressure rating of any downstream equipment. Failure to provide such means of pressure relief could result in damage to the system and personal injury.

For flammable gas, provide ducting to lead relieved gas away from a confined area or ignition source to a safe area, to prevent fire and/or explosion.

The gas used to pressurize the dome must be the same as the gas flowing through the regulator.

Specifications

Gas Service: Oxygen, nitrogen, argon, helium, hydrogen, carbon dioxide, or air.

Maximum Delivery Pressure: 750 PSIG/50 BAR, 500 PSIG/34 BAR

Maximum Inlet Pressure: 3000 PSIG/200 BAR, 4500 PSIG/300 BAR, or 600 PSIG/40 BAR.*

Connections ½" National Pipe Threads, Female.

**See regulator label.*

INSTALLATION

CAUTION

Any regulator which has been contaminated through handling or used in gas service other than oxygen, must not be used for oxygen service. Failure to comply with this precaution may result in fire and/or explosion.

Typical Control Circuits

Conventional Control Circuits

Conventional spring loaded regulator (pilot regulator, "A") is supplied with gas from the inlet side of the dome-loaded regulator. A bleed flows out of the dome to the downstream system, to permit a decrease in regulated pressure. Since the flow is small, the pilot regulator need not have a high flow capacity. The pilot regulator must be suitable for the particular gas used and have the appropriate pressure range.

Flow through the entire system may be started or stopped by opening or closing valve C1 or C2 as desired, or by operating the adjusting screw on the pilot regulator "A".

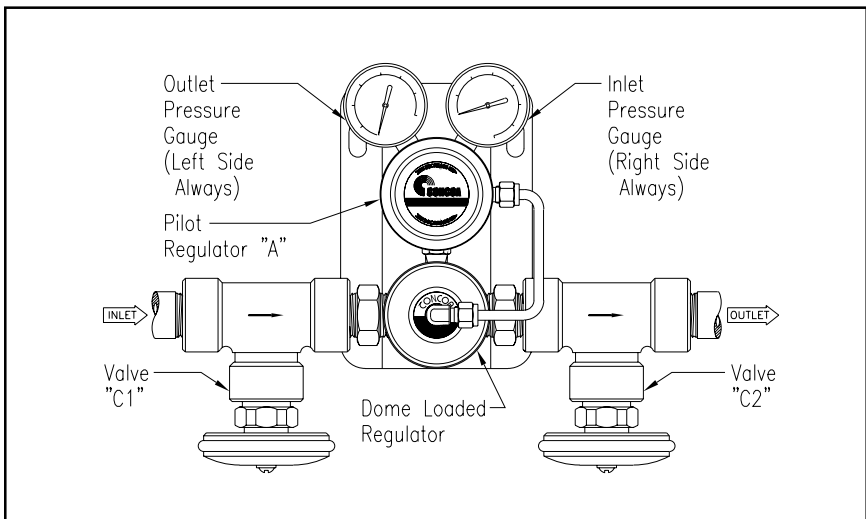

Figure 1. 623 Series Dome Load Regulator and Valves,
(Shown in left hand configuration).

Feedback Control Circuit

This circuit requires a special pilot regulator suitable for the particular gas service and having the diaphragm sensing region separated from the delivery outlet. A bleed flow out of the dome to the downstream system through the sensing line, to permit a decrease in the regulated pressure.

INSTALLATION NOTES

CAUTION

DO NOT INSTALL THIS REGULATOR DIRECTLY TO ANY HIGH PRESSURE CYLINDER OR OTHER SOURCE OF PRESSURE HIGHER THAN THE RATED INLET PRESSURE!

Service Shutoff Valves

A shutoff valve (Figures 1, items C1 and C2) on each side of the regulator will permit servicing.

Pressure Gauges

Install pressure gauges where required for the system.

Oxygen Systems

For oxygen systems use only Teflon[®] pipe thread tape or equivalent pipe thread sealants, approved for oxygen service. Teflon[®]-lined pigtails for oxygen service include a Distance Volume Piece (DVP) at each end to dissipate heat from adiabatic compression.

CAUTION

To avoid fire and/or explosion, every component in an oxygen system (gauges, pipes, fittings) must be clean, and free of any oil or combustible material.

OPERATION

a. Observe precautions in GENERAL SAFETY PRACTICES section, and remember that Maximum Inlet Pressure, depending upon model, is 3000 PSIG/200 BAR, 4500 PSIG/300 BAR, or 600 PSIG/40 BAR. This applies for both pilot and dome-loaded regulators.

b. Begin with regulator, pilot regulator, valves and gauges properly installed in pipeline; downstream equipment connected; valves closed; and adjusting screw of pilot regulator completely released counterclockwise (CCW).

c. Admit inlet pressure to pilot and dome-loaded regulator by opening upstream valve slowly, to avoid sudden pressure surge against dome-loaded regulator.

d. Slowly turn adjusting screw of pilot regulator clockwise (CW) until downstream pressure gauge indicates the desired pressure.

e. Test connections for leaks with a leak testing solution as described in the GENERAL SAFETY PRACTICES section. If no leaks are detected, the system is ready to for use.

f. To shut down the system, close upstream valves and release pilot regulator adjusting screw by turning CCW.

SERVICE

General

A unit which is not functioning properly should not be used until all required repairs have been completed and the unit has been tested to ascertain that it is in proper operating order.

It is recommended that all servicing be done by a service facility authorized by CONCOA. Contact the CONCOA Customer Service Department in Virginia Beach or the nearest CONCOA District Sales Office for assistance.

If so advised, the unit should be sent to a service facility authorized by CONCOA, adequately packaged, in the original shipping container if possible, and shipped prepaid, with a statement of observed deficiency. The gas service that the equipment has been subjected to must be clearly identified. All equipment must be purged before shipment to protect the transporter and service personnel. The purging is especially important if the equipment has been in hazardous or corrosive gas service. Return trip transportation charges are to be paid by Buyer. In all cases other than where warranty is applicable, repairs will be made at current list price for the replacement part(s) plus a reasonable labor charge.

Test regulator for leaks on a routine schedule.

Warranty Information

This equipment is sold by CONTROLS CORPORATION OF AMERICA under the warranties set forth in the following paragraphs. Such warranties are extended only with respect to the purchase of this equipment directly from CONTROLS CORPORATION OF AMERICA or its Authorized Distributors as new merchandise and are extended to the first Buyer thereof other than for the purpose of resale.

For a period of one (1) year from the date of original delivery (90 days in corrosive service) to Buyer or to Buyer's order, this equipment is warranted to be free from functional defects in materials and workmanship and to conform to the description of this equipment contained in this manual and any accompanying labels and/or inserts, provided that the same is properly operated under conditions of normal use and that regular periodic maintenance and service is performed or replacements made in accordance with the instructions provided. The foregoing warranties shall not apply if the equipment has been repaired: other than by CONTROLS CORPORATION OF AMERICA or a designated service facility or in accordance with written instructions provided by CONTROLS CORPORATION OF AMERICA, or altered by anyone other than CONTROLS CORPORATION OF AMERICA, or if the equipment has been subject to abuse, misuse, negligence or accident.

CONTROLS CORPORATION OF AMERICA's sole and exclusive obligation and Buyer's sole and exclusive remedy under the above warranties is limited to repairing or replacing, free of charge, at CONTROLS CORPORATION OF AMERICA's option, the equipment or part, which is reported to its Authorized Distributor from whom purchased, and which if so advised, is returned with a statement of the observed deficiency, and proof of purchase of equipment or part not later than seven (7) days after the expiration date of the applicable warranty, to the nearest designated service facility during normal business hours, transportation charges prepaid, and which upon examination, is found not to comply with the above warranties. Return trip transportation charges for the equipment or part shall be paid by Buyer.

CONTROLS CORPORATION OF AMERICA SHALL NOT BE OTHERWISE LIABLE FOR ANY DAMAGES INCLUDING BUT NOT LIMITED TO: INCIDENTAL DAMAGES, CONSEQUENTIAL DAMAGES, OR SPECIAL DAMAGES, WHETHER SUCH DAMAGES RESULT FROM NEGLIGENCE, BREACH OF WARRANTY OR OTHERWISE.

THERE ARE NO EXPRESS OR IMPLIED WARRANTIES WHICH EXTEND BEYOND THE WARRANTIES HEREINABOVE SET FORTH. CONTROLS CORPORATION OF AMERICA MAKES NO WARRANTY OF MERCHANTABILITY OR FITNESS FOR A PARTICULAR PURPOSE WITH RESPECT TO THE EQUIPMENT OR PARTS THEREOF.



Controls Corporation of America
1501 Harpers Road • Virginia Beach, VA 23454
To Order Call 1-800-225-0473 or 757-422-8330 • Fax 757-422-3125
www.concoa.com