

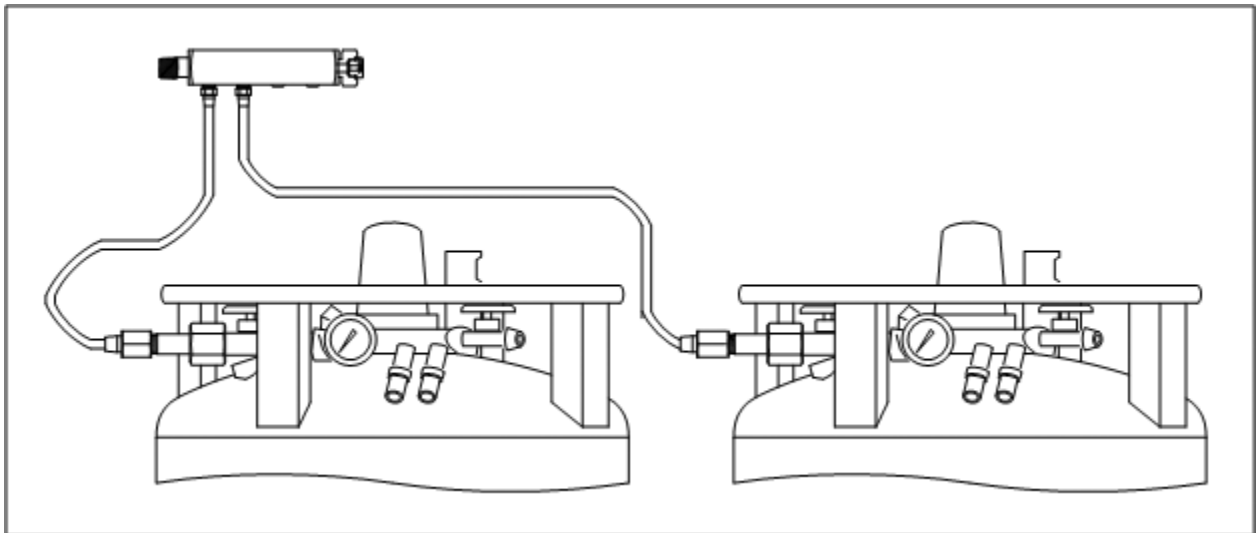

629 Series MicroManifold & Vent Kit System



INSTALLATION AND OPERATION INSTRUCTIONS

Before Installing or Operating, Read and Comply with These Instructions

Controls Corporation of America
1501 Harpers Road Virginia Beach, VA 23454
To Order Call 1-800-225-0473 or 757-422-8330 • Fax 757-422-3125
www.concoa.com

Date April 2005

THIS PAGE INTENTIONALLY LEFT BLANK

DESCRIPTION OF PRODUCT

The 629 Series gas distribution system is available in two configurations. First, the 629-1XXX Series gas manifold is designed to distribute gaseous product from either liquid cans or high-pressure cylinders (3,000 PSI maximum) to a CONCOA pressure control device.

The 629-2XXX Series vent manifold is to be used in conjunction with a 629-1XXX or 628 Series gas manifold. The vent manifold is designed to provide headspace equalization via a common connection for multiple liquid cylinder vent use valves. The 629-2XXX Series vent manifold kit utilizes 72" PTFE-lined stainless armor casing hose (529-0239-01-295 or 529-0239-01-440) with a ¼" MPT manifold connection and a vent use valve flare connection. The 629-2XXX Series vent manifold kit incorporates a flow restrictor at each hose manifold connection as an additional safety feature to prevent hose whip during a cylinder exchange.

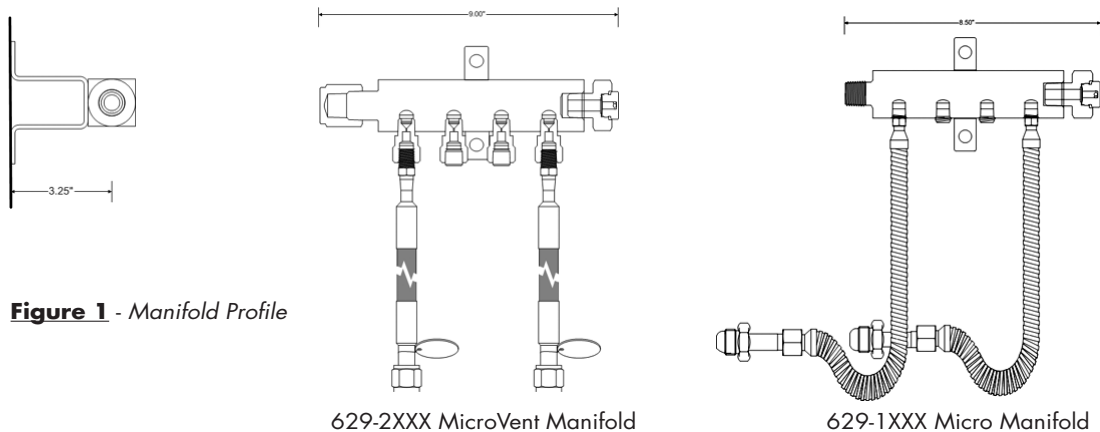

USER RESPONSIBILITY

This equipment will perform in conformity with the description contained in this manual and accompanying labels and/or inserts when installed, operated, maintained, and repaired in accordance with the instructions provided. This equipment must be checked periodically. Improperly working equipment should not be used. Parts that are broken, missing, worn, or distorted should be replaced immediately. CONCOA recommends that a telephone or written request for service advice be made to CONCOA Customer Service in Virginia Beach, Virginia, PHONE: 1-800-225-0473, FAX: 1-757-422-3125, or E-MAIL: e-mail@concoa.com.

This equipment or any of its parts should not be altered without prior written approval by CONCOA. The user of this equipment shall have the sole responsibility for any malfunction that results from improper use, faulty maintenance, damage, improper repair, or alteration by anyone other than CONCOA or a service facility designated by CONCOA.

CUSTOMER ASSISTANCE

In the event of equipment failure, call the CONCOA Customer Assistance Line: 1-800-225-0473. Please be prepared to provide the model number and serial number of the equipment involved, in addition to some details regarding its application. This would include inlet and outlet pressures, flow rate, environmental conditions, and gas service.

Things to consider before removing the system from the box....

1. Know the properties and special handling requirements of the gas being used. Many specialty gases are quite dangerous (flammable, toxic, corrosive, simple asphyxiant, or oxidizers). Equipment failure or misuse may lead to the sudden release of service gas into the surrounding area. Proper safety measures should be established to handle these and other component failures.

2. Be sure that the assembly purchased is suitable for the gas and type of service intended. The label provides the following information:
 - a. Model number
 - b. Serial number

Be sure that the equipment received conforms to the order specifications. The user is responsible for selecting equipment compatible with the gas in use, and conditions of pressure, temperature, flow, etc. Selection information can be found in CONCOA technical data sheets. In addition, CONCOA representatives are trained to aid in the selection process.

3. Inspect the assembly upon receipt to be sure that there is no damage or contamination. Pay particular attention to connecting threads. While CONCOA assembles system components to exacting leak-tight standards, the customer should also inspect for any loosening of parts that may occur in shipping or installation. Loose parts may be dangerously propelled from an assembly. If there are adverse signs (leakage or other malfunction), return the assembly to the supplier. While it is advised that soiled regulators be returned for cleaning, simple external dust or grease may be removed by a clean cloth and if required with aqueous detergent suitable for the application. If there are signs of internal contamination, return to the supplier.
4. Before system startup, it is recommended that all systems be pressure tested, leak tested, and purged with an inert gas such as nitrogen. To accomplish this with connections other than a CGA 580, it will be necessary to use an adapter. The recommended use of an adapter is for temporary use, for start-up and system checks only. Adapters should never be used on a permanent basis.

Comply with precautions listed in C.G.A. Pamphlet P-1, Safe Handling of Compressed Gases in Containers.

GENERAL SAFETY PRACTICES

Under no circumstances should liquid product be allowed into the hoses or manifold

The vent manifold kit hoses (5290239-01-295 and 5290239-01-440) are intended to connect to the liquid can's gaseous vent use valve only. Use with any other gas phase is not safe. A typical liquid has a common flare connection for both the liquid use and vent use valves. Extreme caution must be taken to avoid cryogenic phase exposure to these hoses. Potential personal injury may be a result.

Do not remove the flow restrictors installed into the vent manifold. The restrictors are designed to prevent the hose from whipping while being depressurized.

Consult the cylinder distributor for the proper use of cylinders and for any restrictions on their use (such as flow rate and temperature requirements).

Store cylinders with valve caps screwed on, and cylinders chained to a supporting wall or column.

Handle cylinders carefully and only with valve caps screwed on. The cap will reduce the chance that the cylinder valve will break off if the cylinder is accidentally dropped or falls over. The cap also protects the cylinder valve from damage to screw threads, which could cause leaky connections.

All manifolds used with flammable gases should be provided with approved flashback arrestors to stop any burning gas in the pipeline from getting back to the manifold or cylinders.

No smoking should be permitted near oxygen, nitrous oxide, any other oxidizer, flammable gases, or flammable mixtures, or in areas where cylinders are stored.

Where oxygen or nitrous oxide is used, the manifold and cylinders must be kept clean. No oil, grease, or combustible substances should come in contact with oxygen or nitrous oxide storage or handling equipment. Such materials in contact with oxygen or nitrous oxide are readily ignitable and when ignited, will burn intensely.

Never use an open flame when leak testing.

Always open valves slowly when high-pressure gases are being used.

Always be sure that a cylinder contains the correct gas before connecting it to any manifold.

Always leak-test any manifold or distribution pipeline before using.

Always be sure that the gas in a pipeline is the correct gas for the intended use.

Always close all cylinder valves before disconnecting cylinders from a manifold.

Always remove all empty cylinders from a manifold before connecting full cylinders.

Always test cylinders to be sure the cylinders are full before connecting to a manifold.

Always secure cylinders, whether in use or in reserve.

All gas distribution piping systems must meet the appropriate industrial standards for the intended service and must be thoroughly cleaned before using. For the United States, some applicable safety rules and precautions are listed below:

1. American National Standards Institute standard Z49.1, Safety in Welding and Cutting, American Welding Society, 2501 NW Seventh Street, Miami, Florida 33125
2. N.F.P.A. Standard 51, Oxygen-Fuel Gas systems for Welding and Cutting, N.F.P.A., 470 Atlantic Avenue, Boston, Massachusetts 02210
3. N.F.P.A. Standard 51B, Cutting and Welding Processes (same address as #2).
4. CONCOA publication ADE 872, Safety Precautions in Welding and Cutting.
5. Local Ordinances
6. O.S.H.A. Standard 29 CFR
7. C.G.A. Pamphlet C-4, American National Standard Method of Marking Portable Compressed Gas Containers to Identify the Material Contained.
8. C.G.A. Pamphlet G-4, Oxygen – Information on the properties, manufacture, transportation, storage, handling, and use of oxygen.
9. C.G.A. Pamphlet G-4.1, Equipment Cleaned for oxygen service.
10. C.G.A. Pamphlet G-4.4, Industrial Practices for Gaseous Oxygen Transmission and Distribution Piping Systems.
11. C.G.A. Pamphlet G-5, Hydrogen – Information on the properties, manufacture, transportation, storage, handling, and use of hydrogen.
12. C.G.A. Pamphlet G-6, Carbon Dioxide – Information on the properties, manufacture, transportation, storage, handling, and use of carbon dioxide.
13. C.G.A. Pamphlet G-6.1, Standard for Low Pressure Carbon Dioxide Systems at Consumer Sites.
14. C.G.A. Pamphlet P-1, Safe Handling of Compressed Gases in Containers.
15. C.G.A. Safety Bulletin SB-2, Oxygen Deficient Atmospheres.

*C.G.A. pamphlets can be obtained from the Compressed Gas Association, 1235 Jefferson Davis Highway, Arlington, VA 22202-3239, (703) 979-0900. Publications: (703) 979-4341. Fax: (703) 979-0134.

Keep all cylinders and manifolds away from any source of high temperature over 120°F (50°C) or possible fire hazards. High-pressure gas contained in a closed cylinder becomes increasingly dangerous when exposed to high temperature because pressure increases and the strength of the cylinder decreases. Manifolds installed in open locations should be protected from weather conditions. During winter, protect the manifold from ice and snow. In summer, shade the manifold and cylinders from continuous exposure to direct sunlight. Always leave access to the manifold for cylinder replacement.

LOCATION

The site chosen for the manifold installation shall be level, well ventilated, and at a safe distance from sources of flames, sparks, and excessive heat. The manifold should not be placed in an area that may subject the manifold to damage from passing trucks, cranes, or other heavy machines. Oxygen manifolds must not be installed under shafting, belting, or other places where oil can drip on them. For other location guidelines, see NFPA standard 50 and 51.

INSTALLATION

Installing the system:

1. Be sure to consider all factors when selecting materials.
2. Do not use oil or grease on fittings.
3. Be sure that all fittings are secure and leak tight. Teflon tape should be used on pipe threads.
4. Purge devices: These devices can be purchased as accessories. Purge devices are used to remove toxic, corrosive, or flammable gases from the customer's system to a safe discharge area. This is particularly helpful when an internal problem occurs (such as regulator malfunction).

INSTALLING INLET AND OUTLET CONNECTIONS

Use an open-end wrench, not a pipe wrench, to install accessories to the system. The NPT connections require the use of Teflon tape on the threads to make a gas tight seal. On stainless steel connections, the Teflon tape helps prevent the connections from galling together when tightening or loosening. Follow these rules when using Teflon tape.

Taping procedure:

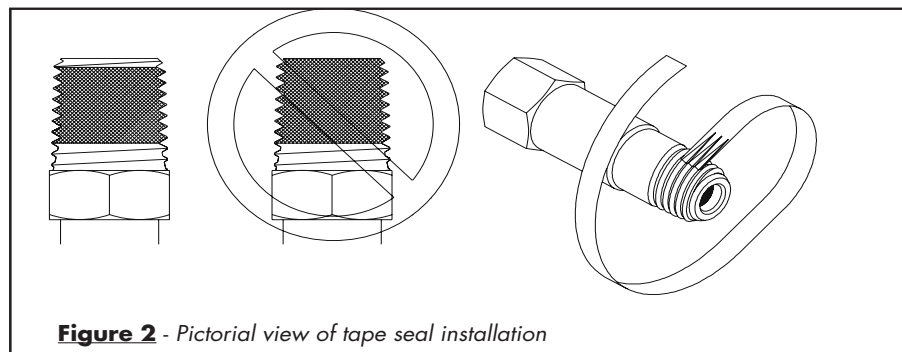

Before applying Teflon tape, inspect the NPT threads and if necessary, clean the fitting to remove any dirt or thread sealant that remains on the threads. Start the Teflon tape on the second thread as shown above; make sure the tape does not overlap the end of the fitting. As the tape is wrapped in the direction of the thread spiral, pull tightly on the end of tape so that the tape conforms to the threads. Apply two overlapping layers of Teflon tape. Cut off the excess tape and press the end firmly into the threads.

WALL MOUNTING

GAS MANIFOLD INSTALLATION FOR USE WITH INTELLISWITCH

1. Determine and mark the vertical center line for installation of the IntelliSwitch system.
2. Measure from the floor 73" and make a mark on the center line. Using a level, draw a horizontal line from the mark extending approximately 10 inches to the left and right of center. The height of 73" is recommended; the typical installation for high-pressure cylinders needs 66 inches between the floor and the "INLET" port. Leave enough space between the cylinder tops and the manifold. (See Figure 3)

Figure 3 - Wall mount installation

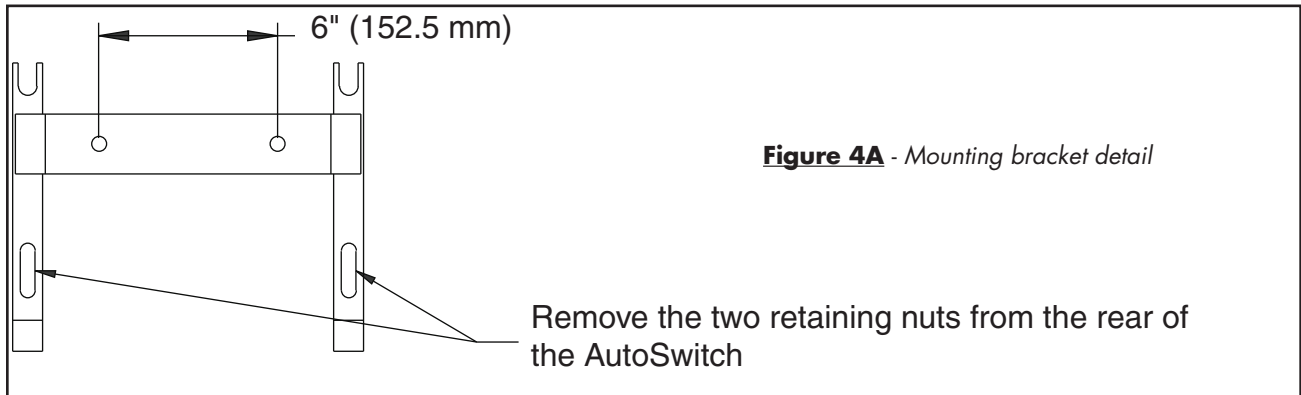
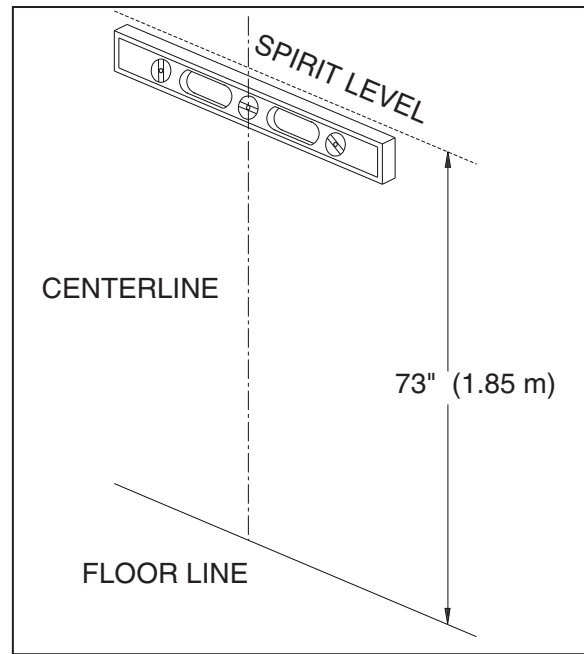

3. Tape the ½" MPT thread on the MicroManifold. Secure the bulkhead with a wrench while threading the male end of the MicroManifold into the IntelliSwitch.
4. If the manifold capacity is five or more cylinders, install a MicroManifold extension kit into the ½" FPT end of the previous MicroManifold. Remember to secure the switchover bulkhead fitting.
5. Tape the ½" MPT thread on the burst disk kit illustrated in Figure 5.
6. Secure the final MicroManifold with a wrench while threading the burst disk kit into the ½" FPT end of the MicroManifold.
7. Attach brackets to back of MicroManifold extension(s) with hardware provided.
8. If necessary, repeat steps 3 through 7 for opposite bank.
9. As illustrated in Figure 4B, the IntelliSwitch enclosure has the mounting bracket holes integrated at each corner. Position the IntelliSwitch, with attached MicroManifold(s), such that the inlet connections are centered on the horizontal line and the outlet on the vertical line.
10. Mark the location of each mounting hole for IntelliSwitch and MicroManifold bracket(s).
11. Using appropriate hardware, anchor the IntelliSwitch then the MicroManifold mounting bracket to the wall.

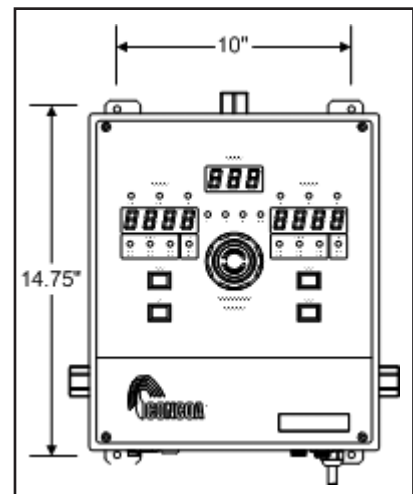

Figure 4B - IntelliSwitch®

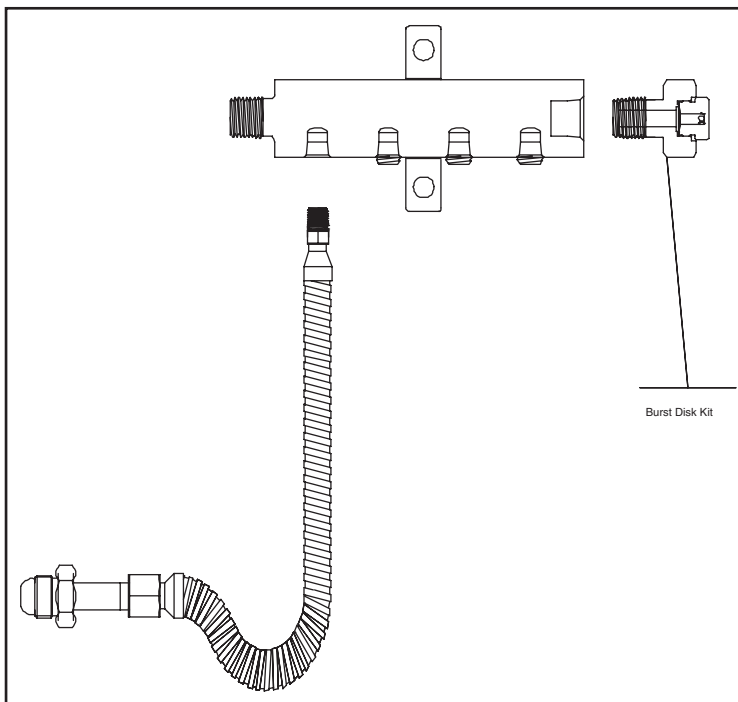

Figure 5 - Gas Manifold
with Burst Disk Kit

9. Make sure that all connections are tightened.
10. Apply PTFE tape to the ¼" MPT end of each pigtail.
11. Remove the desired number of ¼" FPT pipe plugs from the bottom of the MicroManifold block.
12. Install the pigtail into the MicroManifold ¼" FPT port as illustrated in Figure 5.
13. Refer to "Connecting a Cylinder" for directions on connecting the pigtail to the cylinder.
14. Refer to "Pressure Testing the System" to confirm that there are no leaks in the system.

GAS MANIFOLD INSTALLATION FOR USE WITH 635, 636 and 637 AUTOSWITCH SYSTEMS

1. Determine and mark the vertical center line for installation of the AutoSwitch system.
2. Measure from the floor 73" and make a mark on the center line. Using a level, draw a horizontal line from the mark extending approximately 10 inches to the left and right of center. The height of 73" is recommended; the typical installation for high-pressure cylinders needs 66 inches between the floor and the "INLET" port. Leave enough space between the cylinder tops and the manifold. (See Figure 3)
3. For the 637, 636 and 635 gas switchover systems separate the mounting bracket from the rear of the box by removing the nuts at the bottom of the bracket. Place the upper edge of the bracket cross-member on the horizontal line so that it is centered with the vertical line. Holding the bracket with the slotted extensions upright and away from the wall, mark the location of the two mounting bolt holes.
4. Using appropriate hardware, anchor the switchover mounting bracket to the wall. Make sure the bracket is level.
5. Tape the ½" MPT thread on the MicroManifold. Secure the bulkhead with a wrench while threading the male end of the MicroManifold into the switchover.
6. If the manifold capacity is five or more cylinders, install a MicroManifold extension kit into the ½" FPT end of the previous MicroManifold. Remember to secure the switchover bulkhead fitting.
7. Tape the ½" MPT thread on the burst disk kit illustrated in Figure 5.
8. Secure the final MicroManifold with a wrench while threading the burst disk kit into the ½" FPT end of the MicroManifold.
9. Attach brackets to back of MicroManifold extension(s) with hardware provided.
10. If necessary, repeat steps 5 through 9 for opposite bank.

11. Place the switchover unit on the wall bracket and then locate the MicroManifold mounting hardware behind the manifold. Mark the mounting bracket holes.
12. Replace the nuts removed in Step 3 on the back of the AutoSwitch.
13. Using appropriate hardware, anchor the MicroManifold mounting bracket to the wall.
14. Make sure that all connections are tightened.
15. Apply PTFE tape to the ¼" MPT end of each pigtail.
16. Remove the desired number of ¼" FPT pipe plugs from the bottom of the MicroManifold block.
17. Install the pigtail into the MicroManifold ¼" FPT port as illustrated in Figure 5.
18. Refer to "Connecting a Cylinder" for directions on connecting the pigtail to the cylinder.
19. Refer to "Pressure Testing the System" to confirm that there are no leaks in the system.

GAS MANIFOLD INSTALLATION FOR USE WITH ½" PORTED REGULATORS

1. Determine and mark the vertical center line for installation of the manifold.
2. Measure from the floor 73" and make a mark on the center line. Using a level, draw a horizontal line from the mark extending approximately 10 inches to the left and right of center. The height of 73" is recommended; the typical installation for high-pressure cylinders needs 66 inches between the floor and the "INLET" port. Leave enough space between the cylinder tops and the manifold.
3. Tape the ½" MPT thread on the MicroManifold. Secure the regulator while threading the male end of the MicroManifold into the ½" FPT inlet port.
4. Using appropriate hardware, anchor the manifold mounting bracket to the wall. Make sure the bracket is level.
5. Tape the ½" MPT thread on the MicroManifold. Secure the bulkhead with a wrench while threading the male end of the MicroManifold into the regulator.
6. If the manifold capacity has five or more cylinders, install the MicroManifold extension kit into the ½" FPT end of the previous MicroManifold.
7. Tape the ½" MPT thread on the burst disk kit illustrated in Figure 6.

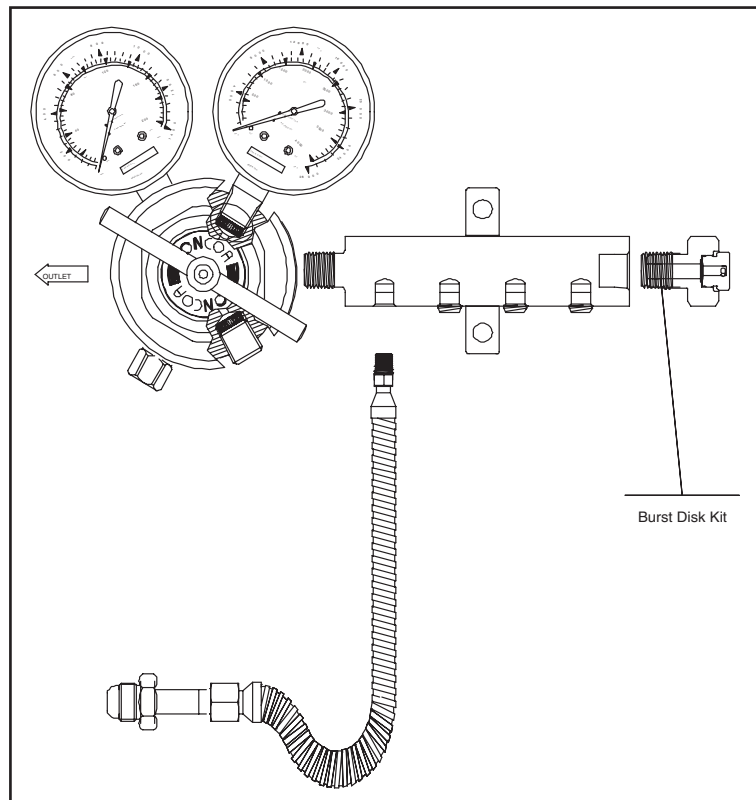
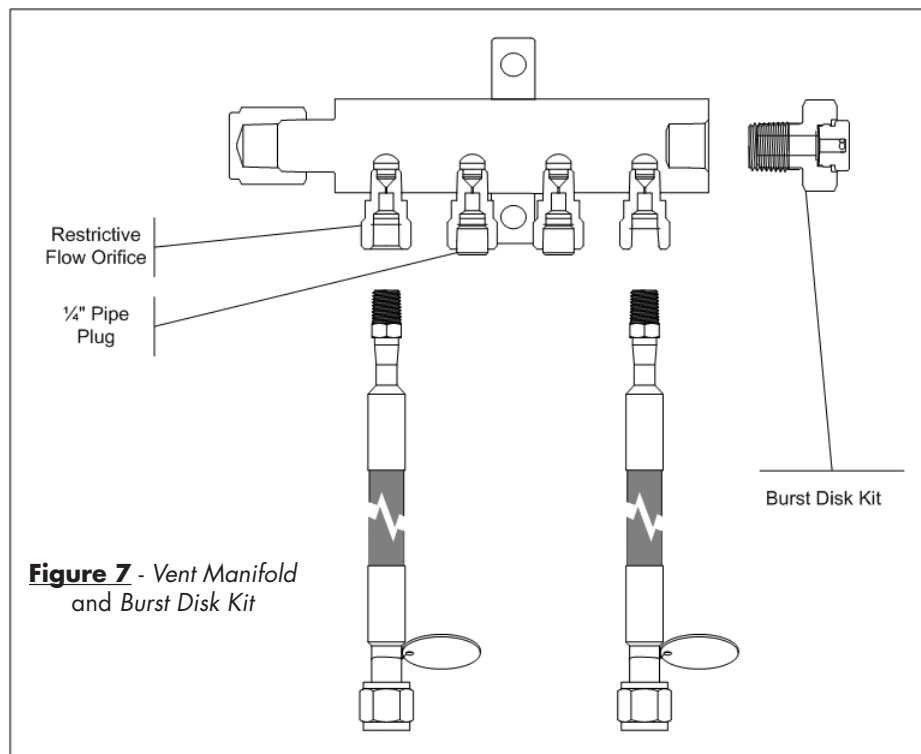

Figure 6 - Regulator and Gas Manifold with Burst Disk Kit

8. Secure the final MicroManifold with a wrench while threading the burst disk kit into the ½" FPT end of the MicroManifold.
9. If the regulator is a 623 Series, install the MicroManifold bracket on the manifold. Place on the wall. Mark the MicroManifold and regulator mounting bracket holes.
10. Using appropriate hardware, anchor the mounting bracket to the wall.
11. Make sure that all connections are tightened.
12. Apply PTFE tape to the ¼" MPT end of each pigtail.
13. Remove the desired number of ¼" FPT pipe plugs from the bottom of the MicroManifold block.
14. Install the pigtail into the MicroManifold ¼" FPT port as illustrated in Figure 6.
15. Refer to "Connecting a Cylinder" for directions on connecting the pigtail to the cylinder.
16. Refer to "Pressure Testing the System" to confirm that there are no leaks in the system.

LIQUID CYLINDER GAS VENT MANIFOLD INSTALLATION FOR USE WITH 629-1XXX OR 628 SERIES GAS MANIFOLDS

1. Center the vent manifold kit 12" above the 629-1XXX or 628 Series gas manifold.
2. If the manifold capacity is five or more liquid cylinders, install a vent manifold extension kit into the ½" FPT end of the previous vent manifold.
3. Secure the final vent manifold with a wrench while threading the burst disk kit into the ½" FPT end of the vent manifold.
4. Using appropriate hardware, anchor the mounting bracket to the wall. Make sure bracket is level.
5. Apply PTFE tape to the ¼" MPT end of each pigtail.
6. Remove the desired number of ¼" FPT pipe plugs from the bottom of the flow restrictor located in the vent manifold block. **Do not remove the flow restrictors.**
7. Install the pigtail into the vent manifold port as illustrated in Figure 7.



8. Repeat steps one through seven if opposite manifold bank is to be used with liquid cylinders.
9. Refer to "Connecting a Cylinder" for directions on connecting the pigtail to the liquid cylinder gas use valve.
10. Refer to "Pressure Testing the System" to confirm that there are no leaks in the system.

CONNECTING A CYLINDER

Read the next section before installing cylinders. The 629-1XXX Series MicroManifold is designed to deliver gaseous phase from either liquid or high-pressure cylinders (3,000 PSI maximum). Never connect both liquid and high-pressure cylinders to the same manifold.

Connecting the High-Pressure Cylinder to the 629-1XXX Gas Manifold

1. Before removing the cylinder cap, move the cylinder with a cylinder cart to the work site:
 - a. Secure cylinder to the floor, wall, stand or bench with the appropriate chain or strap, to prevent toppling.
 - b. Remove the cap if using a high-pressure cylinder.
 - c. Be sure the cylinder valve is tightly closed (clockwise)
 - d. Remove the cylinder valve plug, if any.
 - e. Inspect the cylinder valve and threads for damage or contamination.
2. If using a high-pressure cylinder, secure the pigtail cylinder connection to the cylinder valve in the following manner:
 - a. Thread the nut into the cylinder valve CGA connection. Do not cross thread or force. If it does not fit, the connection may be wrong for the type of gas being used.
 - b. Left-hand threads are used on left-hand cylinder connections. They can be identified by the notch in the middle of the hex nut.
 - c. PTFE gaskets or washers are used on some inlet connections, such as carbon dioxide CGA 320. Be sure the gasket is in good shape. Do not over-tighten to avoid deforming the gasket, which may create a leak or failure.
3. Open each cylinder gas use valve after all new cylinders have been properly connected and secured.
4. The micro manifold is ready for use.

Connecting the Liquid Cylinder to the 629-1XXX Gas Manifold

1. Before removing the cylinder cap, move the cylinder with a cylinder cart to the work site:
 - a. Secure cylinder to the floor, wall, stand or bench with the appropriate chain or strap, to prevent toppling.
 - b. The large diameter ring located at the top of a liquid cylinder protects the cylinder valves instead of a cap.
 - c. Be sure the cylinder valve is tightly closed (clockwise)
 - d. Remove the cylinder valve plug, if any.
 - e. Inspect the cylinder valve and threads for damage or contamination.
2. If the gas supply source is a liquid cylinder, identify the gas use valve before making a connection.
 - a. **WARNING: Connect ONLY to GAS USE Valve.**
 - b. **WARNING: The carbon dioxide liquid cylinder incorporates a CGA 320 connection on both the gas use and liquid fill valves. Premature pigtail failure may occur if a polymer lined pigtail is exposed to cryogenic liquid temperature.**
 - c. **WARNING: Never use oil or grease on regulator or cylinder fittings, as it may contaminate pure gases, or create a fire hazard.**
3. Secure the pigtail cylinder connection to the liquid cylinder gas phase use valve in the following manner:
 - a. Close the gas use valve (clockwise) of each liquid cylinder connected to the gas phase manifold.
 - b. If replacing an empty cylinder, loosen the pigtail flare connection to the cylinder's gas phase use valve a quarter turn to depressurize the vent manifold. A restrictive flow orifice has been installed between the manifold block and the pigtail to prevent whipping during a cylinder exchange.
 - c. Finish removing the cylinder connection.
 - d. Replace the empty cylinders.

4. Open each cylinder gas use valve after all new cylinders have been properly connected and secured.
5. If using a liquid cylinder, open the liquid cylinder pressure building (PB) valve and adjust the PB regulator at least 50 psi above the pressure control device line pressure. A greater pressure differential may be required for higher flow requirements
6. The micro manifold is ready for use.

Connecting the Liquid Cylinder to the 629-2XXX Vent Manifold

Read the next section before installing cylinders. The 629-2XXX Series vent manifold is to be used in conjunction with a 629-1XXX or 628 Series gas manifold. The vent manifold is designed to provide headspace equalization via a common connection for multiple liquid cylinder vent use valves.

1. Move the liquid cylinder with a cylinder cart to the work site:
 - a. Secure cylinder to the floor, wall, stand or bench with the appropriate chain or strap to prevent toppling.
 - b. The large diameter ring located at the top of the liquid cylinder protects the piping and valves.
 - c. Be sure all cylinder valves are tightly closed. (Clockwise)
 - d. Remove the cylinder valve plug, if any.
 - e. Inspect valves and threads for damage or contamination.
2. Secure the pigtail cylinder connection to the liquid cylinder vent use valve in the following manner:
 - a. Close the vent use valve (clockwise) of each liquid cylinder connected to the vent manifold.
 - b. If replacing an empty cylinder, loosen the pigtail flare connection to the cylinder's vent use valve a quarter turn to depressurize the vent manifold. A restrictive flow orifice has been installed between the manifold block and the pigtail to prevent whipping during a cylinder exchange.
WARNING: The operator should secure the pigtail with one hand until exhausting of gas has subsided.
 - c. Finish removing the flare connection.
 - d. Replace the empty cylinders.
 - e. Thread the pigtail flair nut onto the vent use valve CGA 295 or 440-flare connection of each cylinder. Do not cross thread or force. If it does not fit, the connection may be wrong for the type of gas being used.
WARNING: Connect ONLY to VENT USE Valve.
WARNING: Use extra caution when reconnecting the pigtail to the new liquid cylinder vent use valve. Both the vent and liquid use valves incorporate the same connection.
 - f. After all vent cylinders are attached to the vent manifold, open each vent use valve (counterclockwise).
 - g. Open the liquid cylinder pressure building (PB) valve and adjust the PB regulator at least 50 psi above the pressure control device line pressure. A greater pressure differential may be required for higher flow requirements.
 - h. The vent manifold is ready for use.

Pressure Testing the 629-1XXX Gas Manifold

Before system startup, it is recommended that all systems be pressure tested, leak tested, and purged with a clean, dry inert gas like helium or argon.

1. Wear safety glasses and gloves.
2. Connect last pigtail on the manifold to a test cylinder regulated to 50 psi as illustrated in Figure 8. Do not open the cylinder valve yet.
3. Make sure all pigtails have been properly secured to the 629-1xxx gaseous withdrawal manifold.
4. Isolate the outlet of the pressure control device (Regulator or Switchover) from the piping leading to the point of use. This will allow you to confirm that the manifold and pressure control device is leak free. It is not uncommon for there to be a small leak in the pipe line or point of use.

Figure 8 - Test Regulator and Cylinder

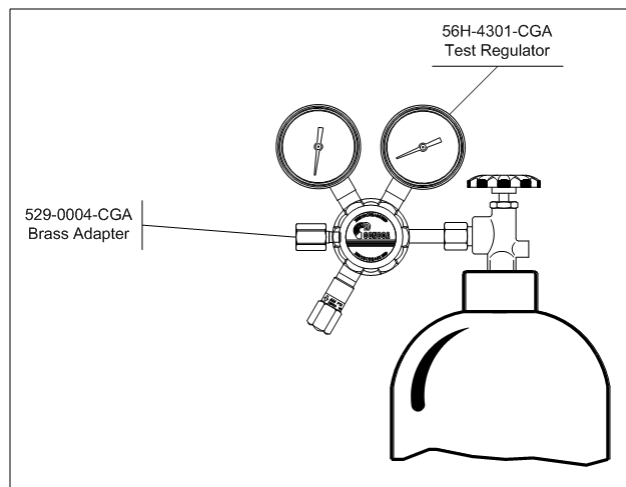

5. When first pressurizing, do not stand in front or in contact with regulator or switchover system.
Warning: If the attached regulator is preset, gas will escape from the delivery side of the pressure control device.
6. Turn the adjusting screw or knob of the test regulator counterclockwise until it disengages the adjusting spring.
7. Slowly, open the test cylinder valve.
8. Next, adjust the test regulator to 50 psi.
9. Wait 5-10 seconds for the system pressure to equalize.
10. Close the test cylinder valve.
11. Inspect all connections for leaks and fix any leaks. A leak detection solution may be applied to the connections (if compatible with the application) which indicates leaks by bubbling. To further check for leaks or if a leak detection solution can not be used, keep test cylinder valve closed for a period of time (24 hours) and observe the test regulator's low pressure gauge for a drop in pressure.
12. If a drop in pressure is observed, recheck all connections.
13. Depressurize the system at the point of use to atmosphere by opening the delivery line regulator and isolation valves. Once pressure is relieved, close regulator and isolation valve. Fix leaking connection. Never attempt to fix a leak under pressure.
14. Once all connections are secure and leak free continue to the next step.
15. Now set the outlet pressure of the pressure control device and open any isolation valve to allow the pipe line to pressurize.
16. Repeat steps 5-14.
17. When all leaks are fixed, close the test cylinder valve. Bleed system pressure to zero.
18. Disconnect the test cylinder and regulator.
19. Connect service gas cylinders to the manifold by following the section titled "Connecting a Cylinder".
20. Open service gas cylinder valves and repeat steps 11 - 15 until all leaks are eliminated.
21. System is ready for use.

Pressure Testing 629-2XXX Vent Manifold

Before system startup, it is recommended that all systems be pressure tested, leak tested, and purged with a clean, dry inert gas like helium or argon.

1. Wear safety glasses and gloves.
2. Follow the "Connecting a Cylinder" section and connect all cylinders to the vent manifold.*** Do not open the liquid cylinder gas use valves.
3. Make sure all pigtails have been properly secured to the 629-2xxx vent manifold.
4. Slowly, open the vent use valve on the last liquid cylinder.
5. Next, wait 5-10 seconds for the vent manifold system pressure to equalize.

6. Close the cylinder vent use valve.
7. Inspect all connections for leaks and fix any leaks. A leak detection solution may be applied to the connections (if compatible with the application) which indicates leaks by bubbling.
8. If a leak is observed, depressurize the system and fix leaking connection. Loosen the pigtail flare connection to the cylinder's vent use valve a quarter turn to depressurize the vent manifold. A restrictive flow orifice has been installed between the manifold block and the pigtail to prevent whipping during a cylinder exchange. Never attempt to fix a leak under pressure.
WARNING: The operator should secure the pigtail with one hand until exhausting of gas has subsided.
9. Once all connections are secure and leak free continue the vent manifold is ready for use.

OPERATION

Follow the instructions supplied with the regulator, IntelliSwitch, or AutoSwitch when operating these devices. When removing a cylinder from the manifold, the manifold header valve must be closed first.

MAINTENANCE

At regular intervals, the Manifold system should be checked for leaks and proper function (see Troubleshooting). The pigtail check valve should also be checked for leaks when a depleted cylinder is removed. Note: the system inlet and pigtail should be pressurized when checking for leaks. Any leaks in the system should be corrected immediately.

TROUBLESHOOTING

Typical symptoms listed below indicate MicroManifold system malfunctions needing repair. Replace immediately with a clean, repaired and tested, or new system.

1. Gas leakage from any joint.
2. Manifold master valve when closed does not cut off the gas supply to the regulator, IntelliSwitch, or AutoSwitch.
3. The system makes a noise or hums.

SERVICE

A Unit that is not functioning properly should not be used and should be returned to CONCOA for service. A Return Material Authorization (RMA) number must be issued for any product returned to CONCOA for service. Please contact a Customer Service Representative at 1-800-225-0473 to receive this number. You will be asked to provide:

1. Model Number
2. Gas Service
3. Inlet pressure and type of gas supply
4. Outlet pressure
5. Approximate gas usage

When shipping product back to CONCOA for repair the following steps should be followed:

1. Package the product sufficiently to prevent damage. If possible return product in its original packing.
2. Include RMA number on the outside of the carton.
3. Ship prepaid.
4. Include a written description of the problem you encountered with the product inside the package.
5. Include a statement of the gas service the product was used in.
6. Purge all equipment before shipping to protect the transporter and service personnel. Purging is especially important if the equipment has been in hazardous or corrosive gas service.

Return trip transportation charges are to be paid by the Buyer. In all cases where the warranty has expired, repairs will be made at current list price for the replacement part(s), plus a reasonable labor charge.

Warranty Information

This equipment is sold by CONTROLS CORPORATION OF AMERICA under the warranties set forth in the following paragraphs. Such warranties are extended only with respect to the purchase of this equipment directly from CONTROLS CORPORATION OF AMERICA or its Authorized Distributors as new merchandise and are extended to the first Buyer thereof other than for the purpose of resale.

For a period of one (1) year from the date of original delivery (90 days in corrosive service) to Buyer or to Buyer's order, this equipment is warranted to be free from functional defects in materials and workmanship and to conform to the description of this equipment contained in this manual and any accompanying labels and/or inserts, provided that the same is properly operated under conditions of normal use and that regular periodic maintenance and service is performed or replacements made in accordance with the instructions provided. The foregoing warranties shall not apply if the equipment has been repaired: other than by CONTROLS CORPORATION OF AMERICA or a designated service facility or in accordance with written instructions provided by CONTROLS CORPORATION OF AMERICA, or altered by anyone other than CONTROLS CORPORATION OF AMERICA, or if the equipment has been subject to abuse, misuse, negligence or accident.

CONTROLS CORPORATION OF AMERICA's sole and exclusive obligation and Buyer's sole and exclusive remedy under the above warranties is limited to repairing or replacing, free of charge, at CONTROLS CORPORATION OF AMERICA's option, the equipment or part, which is reported to its Authorized Distributor from whom purchased, and which if so advised, is returned with a statement of the observed deficiency, and proof of purchase of equipment or part not later than seven (7) days after the expiration date of the applicable warranty, to the nearest designated service facility during normal business hours, transportation charges prepaid, and which upon examination, is found not to comply with the above warranties. Return trip transportation charges for the equipment or part shall be paid by Buyer.

CONTROLS CORPORATION OF AMERICA SHALL NOT BE OTHERWISE LIABLE FOR ANY DAMAGES INCLUDING BUT NOT LIMITED TO: INCIDENTAL DAMAGES, CONSEQUENTIAL DAMAGES, OR SPECIAL DAMAGES, WHETHER SUCH DAMAGES RESULT FROM NEGLIGENCE, BREACH OF WARRANTY OR OTHERWISE.

THERE ARE NO EXPRESS OR IMPLIED WARRANTIES WHICH EXTEND BEYOND THE WARRANTIES HEREINABOVE SET FORTH. CONTROLS CORPORATION OF AMERICA MAKES NO WARRANTY OF MERCHANTABILITY OR FITNESS FOR A PARTICULAR PURPOSE WITH RESPECT TO THE EQUIPMENT OR PARTS THEREOF.

AD13221-A



Controls Corporation of America
1501 Harpers Road Virginia Beach, VA 23454
To Order Call 1-800-225-0473 or 757-422-8330 • Fax 757-422-3125
www.concoa.com