



# The 530 Series Automatic Switchover System

For use with  
Non-Oxidizing,  
Non-Toxic and  
Non-Corrosive Gases  
(Not For Use with O<sub>2</sub>, N<sub>2</sub>O or CO<sub>2</sub>)

## **INSTALLATION AND OPERATION INSTRUCTIONS**

Before Installing or Operating, Read and Comply with These Instructions

Controls Corporation of America  
1501 Harpers Road • Virginia Beach, VA 23454  
To Order Call 1-800-225-0473 or 757-422-8330 • Fax 757-422-3125

[www.concoa.com](http://www.concoa.com)

August 2001

## DESCRIPTION OF PRODUCT

The 530 Series switchover is an automatic switchover system designed to provide a continuous supply of high pressure gas. This unit may be used with up to two cylinders per side. The inlet of the switchover system always includes shut-off valves and may be purchased with flexible pigtails.

With 530 XXX3 or XXX4 models, an optional remote alarm provides an audible and visual warning that a changeover is about to occur. Pressing a button on the front of the remote alarm silences the audible alarm. The LED's on the remote alarm indicate the status of the left and right banks.

Model Number	Outlet Pressure (with Line Regulator)	
530 1XXX	1000 PSIG	70 BAR
530 2XXX	1500 PSIG	100 BAR
530 3XXX	2500 PSIG	170 BAR
530 4XXX	3500 PSIG	240 BAR

### System Configuration With Line Regulator

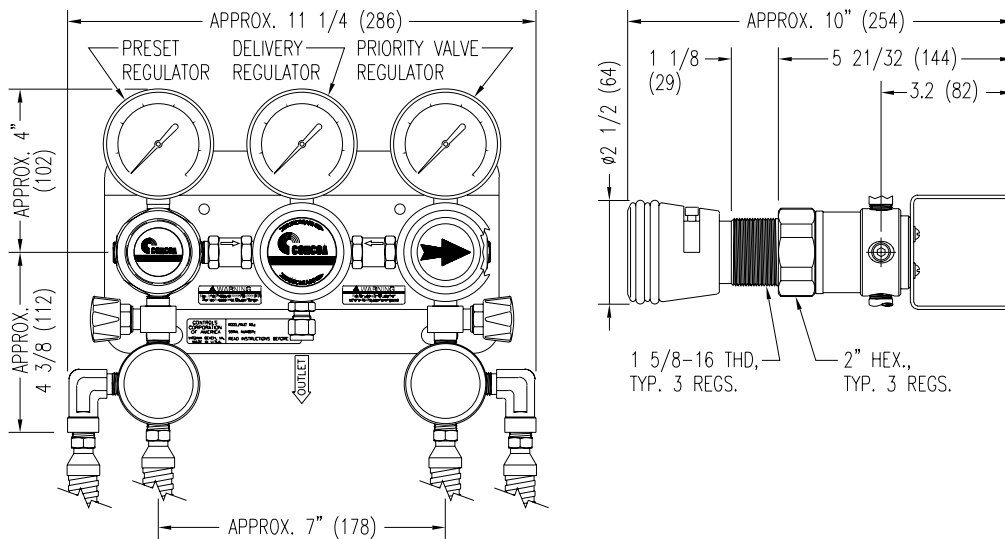

Pigtail with  
Cylinder Connection

Figure 1. System Configurations and Parts

## INTENDED USE OF PRODUCT

The chrome-plated brass switchover system (530 series) is intended for use in non-oxidizing, non-corrosive, non-toxic gas applications (Not for use in O<sub>2</sub>, N<sub>2</sub>O, or CO<sub>2</sub>). Please note the safety information shown in the later sections. System is designed to operate at flows less than 4000 SCFH.

## USER RESPONSIBILITY

This equipment will perform in conformity with the description contained in this manual and accompanying labels and/or inserts when installed, operated, maintained, and repaired in accordance with the instructions provided. This equipment must be checked periodically. Improperly working equipment should not be used. Parts that are broken, missing, worn, distorted or contaminated, should be replaced immediately. CONCOA recommends that a telephone or written request for service advice be made to CONCOA Customer Service in Virginia Beach, Virginia. PHONE: 1-800-225-0473, FAX: 1-757-422-3125, or E-MAIL: e-mail@concoa.com.

This equipment or any of its parts should not be altered without prior written approval by CONCOA. The user of this equipment shall have the sole responsibility for any malfunction that results from improper use, faulty maintenance, damage, improper repair, or alteration by anyone other than CONCOA or a service facility designated by CONCOA.

## CUSTOMER ASSISTANCE

In the event of equipment failure, call CONCOA Customer Service. Please be prepared to provide the model number and serial number of the equipment involved, in addition to some details regarding its application. This would include inlet and outlet pressures, flow rate, environmental conditions, and gas service.

### Things to consider before removing the system from the box....

1. Know the properties and special handling requirements of the gas being used. Many specialty gases are quite dangerous (flammable, asphyxiant, etc.). Equipment failure or misuse may lead to problems such as a release of gas through the regulator cartridge. Proper safety measures should be established to handle these and other component failures.
2. Be sure that the assembly purchased is suitable for the gas and type of service intended. The regulator label provides the following information:
  - a. Model number
  - b. Serial number
  - c. Maximum inlet pressure

Be sure that the equipment received conforms to the order specifications. The user is responsible for selecting equipment compatible with the gas in use, and conditions of pressure, temperature, flow, etc. Selection information can be found in CONCOA's *Pressure and Flow Control Specialty Gas Catalog*. In addition, CONCOA representatives are trained to aid in the selection process.

3. Inspect the assembly upon receipt to be sure that there is no damage or contamination. Pay particular attention to connecting threads. While CONCOA assembles system components to exacting leak-tight standards, the customer should also inspect for any loosening of parts that may occur in shipping or installation. Loose parts may be dangerously propelled from an assembly. If there are adverse signs (leakage or other malfunction), return the assembly to the supplier. While it is advised that soiled regulators be returned for cleaning, simple external dust or grease may be removed by a clean cloth and if required with aqueous detergent suitable for the application. If there are signs of internal contamination, return to the supplier.

4. Before system startup, it is recommended that all systems be pressure tested, leak tested, and purged with an inert gas such as nitrogen. To accomplish this with connections other than a CGA 580, it will be necessary to use an adapter. The recommended use of an adapter is for temporary use, for start-up and system checks only. Adapters should never be used on a permanent basis.

## GENERAL SAFETY PRACTICES



### C A U T I O N

- √ Comply with precautions listed in C.G.A. Pamphlet P-1, Safe Handling of Compressed Gases in Containers.
- √ Consult the cylinder distributor for the proper use of cylinders and for any restrictions on their use (such as flow rate and temperature requirements).
- √ Store cylinders with valve caps screwed on, and cylinders chained to a supporting wall or column.
- √ Handle cylinders carefully and only with valve caps screwed on. The cap will reduce the chance that the cylinder valve will break off if the cylinder is accidentally dropped or falls over. The cap also protects the cylinder valve from damage to screw threads, which could cause leaky connections.
- √ All manifolds used with flammable gases should be provided with approved flashback arrestors to stop any burning gas in the pipeline from getting back to the manifold or cylinders.
- √ No smoking should be permitted near oxygen, nitrous oxide, any other oxidizer, flammable gases, or flammable mixtures, or in areas where cylinders are stored.
- √ Never lift gas cylinders with a magnetic lifting device.
- √ Never use an open flame when leak testing.
- √ Before disconnecting nearly empty cylinders, always rotate the priority valve 180° so that the arrow on the knob is pointing to the in-use (full) side of the switchover.



### C A U T I O N

- √ Always close all manifold station and cylinder valves on the nearly empty side of the switchover before disconnecting the pigtail CGA fitting.
- √ Always stand to the side and slowly open the pigtail cylinder connection nut.
- √ Always tighten the CGA on all new cylinders before opening any valves.
- √ Always open valves slowly when high-pressure gases are being used.
- √ Always be sure that a cylinder contains the correct gas before connecting it to any manifold.
- √ Always leak-test any manifold or distribution pipeline before using.
- √ Always be sure that the gas in a pipeline is the correct gas for the intended use.
- √ Always close all cylinder valves before disconnecting cylinders from a manifold.
- √ Always test cylinders to be sure the cylinders are full before connecting to a manifold.

All gas distribution piping systems must meet the appropriate industrial standards for the intended service and must be thoroughly cleaned before using. For the United States, some applicable safety rules and precautions are listed below:

1. American National Standards Institute Standard Z49.1, Safety in Welding and Cutting, American Welding Society, 2501 NW Seventh Street, Miami, Florida 33125
2. N.F.P.A. Standard 51, Oxygen-Fuel Gas systems for Welding and Cutting, N.F.P.A., 470 Atlantic Avenue, Boston, Massachusetts 02210
3. N.F.P.A. Standard 51B, Cutting and Welding Processes (same address as #2).
4. CONCOA publication ADE 872, Safety Precautions in Welding and Cutting.
5. Local Ordinances
6. O.S.H.A. Standard 29 CFR
7. C.G.A. Pamphlet C-4, American National Standard Method of Marking Portable Compressed Gas Containers to Identify the Material Contained.
8. C.G.A. Pamphlet G-5, Hydrogen – Information on the properties, manufacture, transportation, storage, handling, and use of hydrogen.
9. C.G.A. Pamphlet G-6, Carbon Dioxide – Information on the properties, manufacture, transportation, storage, handling, and use of carbon dioxide.
10. C.G.A. Pamphlet G-6.1, Standard for Low Pressure Carbon Dioxide Systems at Consumer Sites.
11. C.G.A. Pamphlet P-1, Safe Handling of Compressed Gases in Containers.
12. C.G.A. Safety Bulletin SB-2, Oxygen Deficient Atmospheres.

\*C.G.A. pamphlets can be obtained from the Compressed Gas Association, 1235 Jefferson Davis Highway, Arlington, VA 22202-3239, (703) 979-0900. Publications: (703) 979-4341. Fax: (703) 979-0134.

## INSTALLATION

Keep all cylinders and manifolds away from any source of high temperature over 120°F (50°C) or possible fire hazards. High-pressure gas contained in a closed cylinder becomes increasingly dangerous when exposed to high temperature because pressure increases and the strength of the cylinder decreases. Manifolds installed in open locations should be protected from weather conditions. During winter, protect the manifold from ice and snow. In summer, shade the manifold and cylinders from continuous exposure to direct sunlight. Always leave access to the manifold for cylinder replacement.

The site chosen for the manifold installation shall be level, well ventilated, and at a safe distance from sources of flames, sparks, and excessive heat. The manifold should not be placed in an area that may subject the manifold to damage from passing trucks, cranes, or other heavy machines. For other location guidelines, see NFPA standard 51.

Consider the following when installing the system.

- a. Be sure to consider all factors when selecting materials, particularly pressure rating and gas compatibility.
- b. Do not use oil or grease on fittings.
- c. Be sure that all fittings are secure and leak tight. Teflon tape should be used on pipe threads.

Mount the switchover system to a flat surface using the appropriate hardware at hole locations provided in the bracket. Dimensions for these holes are shown in Figure 2 (next page).

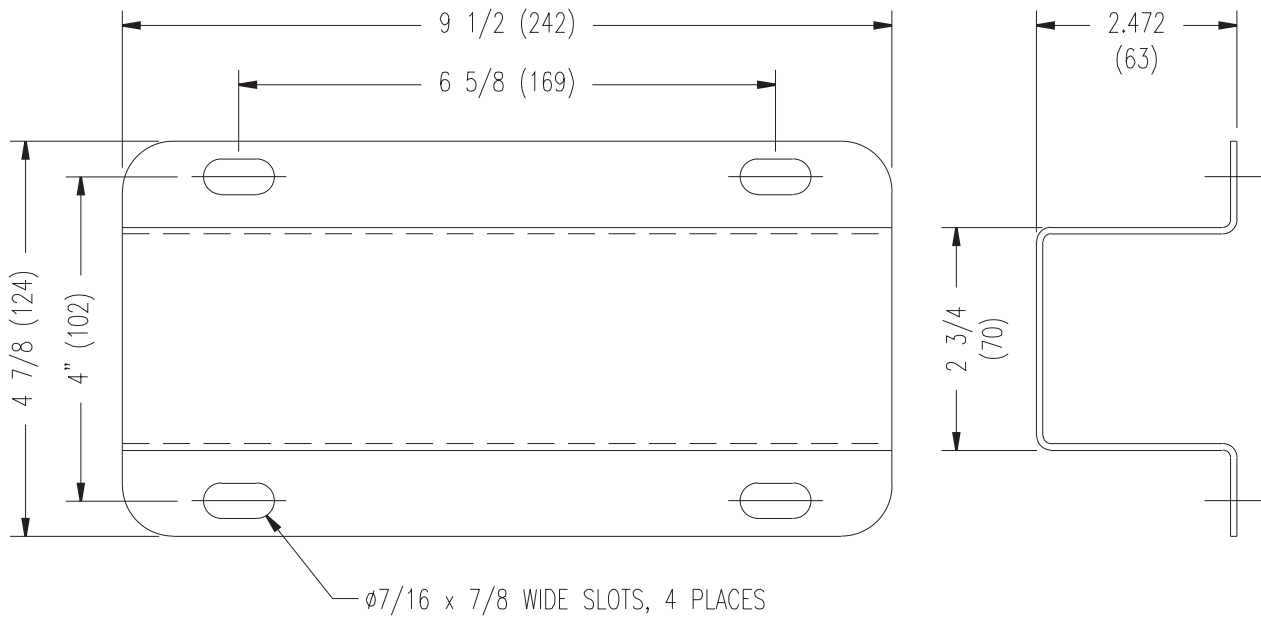

Figure 2. Installation Bracket

Install inlet and outlet connections to the switchover. Use an open-end wrench, not a pipe wrench, to install accessories to the autoswitch system. 1/4" NPT connections require the use of Teflon tape on the threads to make a gas tight seal. CONCOA uses Teflon tape on all of its regulator NPT connections. Follow these rules when using Teflon tape.

Inspect the NPT threads and if necessary, clean the fitting to remove any dirt or thread sealant that remains on the threads. Start the Teflon tape on the second thread as shown in Figure 3; make sure the tape does not overlap the end of the fitting. As the tape is wrapped in the direction of the thread spiral, pull tightly on the end of tape so that the tape conforms to the threads. Wrap the tape around the threads twice. Cut off the excess tape and press the end firmly into the threads. (See Figure 3 below.)

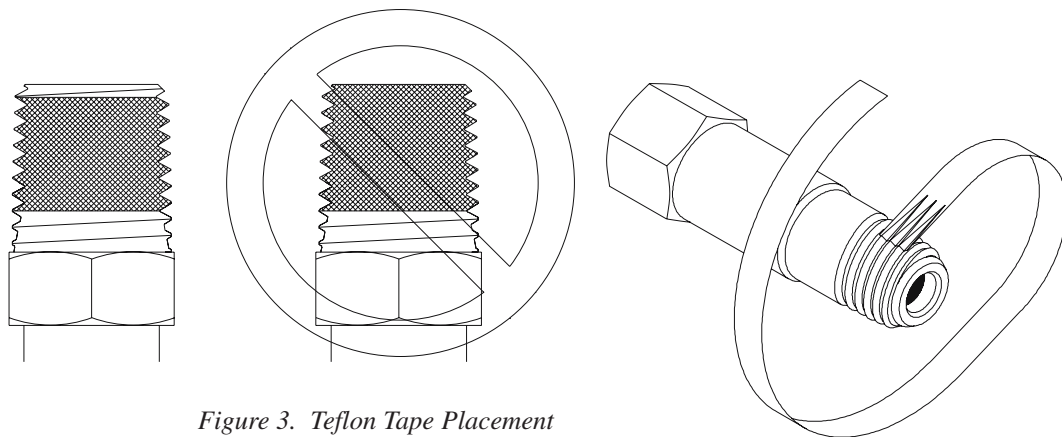

Figure 3. Teflon Tape Placement

Installing the inlet connection:

If purchased with pigtails, the male  $\frac{1}{4}$ " NPT end of the pigtail is installed into the "INLET" port or in the open, female port of the valve.

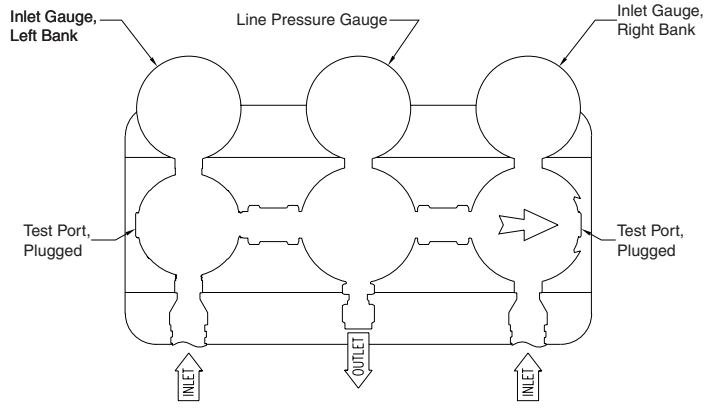

Figure 4. System configuration for installing the inlet connection.

The connection available at the other end of the pigtail will depend on how the system was purchased. If the pigtail does not have a cylinder connection installed, there will be a female  $\frac{1}{4}$ " NPT on the end of the pigtail. The female  $\frac{1}{4}$ " NPT pigtail end will connect to the user's system. If configured with a CGA connection or international inlet connection, the connection will be specific to the particular cylinder of gas to be used. Some connections do require the use of a gasket. Please note that the material of the gasket must also be compatible with the type of gas being used. Be familiar with the type of connection being used, and its proper procedures for installation.

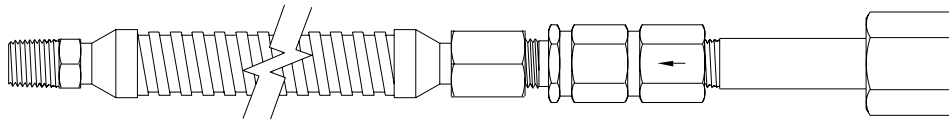

Figure 5. Pigtail with Cylinder Connection

Connecting to a cylinder:

1. Before removing the cylinder cap, move the cylinder of gas to the work site:
  - a. Secure cylinder to the floor, wall, or bench with appropriate chain, strap, or stand to prevent toppling.
  - b. Remove the cylinder cap.
  - c. Be sure the cylinder valve is tightly closed (clockwise)
  - d. Remove the cylinder valve plug, if any.
  - e. Inspect the cylinder valve and threads for damage or contamination.
2. Secure the cylinder connection to the cylinder in the following manner:
  - a. Do not force. Tightening the nut onto the cylinder connection should be easy. If it is not, the connection may be wrong for the type of gas being used.

- b. Left-hand threads are used on some cylinder connections. A notch in the middle of the hex nut typically indicates a left-hand thread.
- c. Gaskets are used on some inlet connections. Be sure the gasket is in good shape. Do not over-tighten to avoid squashing the gasket into the gas line. Keep extra gaskets on hand.
- d. Never use oil or grease on regulator or cylinder fittings, as it may contaminate pure gases, or create a fire hazard.

Installing the outlet connection:

The standard system has the outlet connection at the bottom of the switchover system. The connection is a ¼ 316 stainless steel Swagelok® tube fitting. Insert appropriate ¼"OD tubing until it bottoms out in the fitting. Turn the nut clockwise until hand tight. Continue tightening with an open end wrench. Full make up is 1¼ turns from the handtight position.

Pressurizing the system for the first time:

Before system startup, it is recommended that all systems be pressure tested, leak tested, and purged with an inert gas such as nitrogen. To accomplish this with connections other than a CGA 580, it will be necessary to use an adapter. The recommended use of an adapter is for temporary use only, for system start up and checks. Adapters should never be used on a permanent basis.

1. Wear safety glasses and gloves.
2. Be sure that both ends of all hoses or pigtailed are secured before pressurizing. Turn the line regulator (center regulator) knob counterclockwise until the knob stops turning.
3. When first pressurizing, do not stand in front of or contact the switchover system. Slowly open the cylinder valve. Observe the high pressure gauge for a rise in pressure up to full cylinder pressure.
4. Keep the hand wheel or wrench on the open cylinder valve at all times, to allow prompt emergency shut-off.
5. Inspect all connections for leaks and fix any leaks. A leak detection solution may be applied to the connections (if compatible with the application) which indicates leaks by bubbling. To further check for leaks, or if the leak detection solution can not be used, close the cylinder valve for a period of time (recommended 24 hours), and observe the high pressure gauge for a drop in pressure. If so indicated, recheck the CGA connection and all other high-pressure port connections.
6. Never attempt to fix a leak under pressure. If leaks are detected, depressurize the system and retighten the connection. Begin again at step 3.
7. Slowly turn the line regulator knob clockwise. This will increase the pressure of the line. Adjust to the desired working pressure and again check for leaks using the methods described above.

## OPERATION

The arrow on the priority valve always points to the primary side; the bank opposite the primary side is considered the reserve side. Starting with the arrow pointing to the right side, gas will flow from the right side cylinder. As the gas in the primary side is depleted, the gas pressure will drop on the gauge of the primary regulator. When the pressure drops to the pressure setting of the reserve side regulator, flow will begin from the reserve cylinder; the inlet pressure on the primary side will stabilize. This is called a changeover. At this point, the gas pressure on the reserve side (preset regulator) will drop. This indicates that its time to change the cylinders on the primary side. Before removing the nearly depleted primary cylinder, the priority valve should be rotated 180°. This makes the reserve cylinder the primary source. Remove the depleted cylinder and replace with a full cylinder. Before removing the cylinder be sure to close the cylinder valve and any other valves that connect the cylinder to the system. Do not open any cylinder valves until all cylinders are replaced. The full, replacement cylinder is now the reserve cylinder. Note: while changing cylinders on one side, there will be no interruption in flow. A depleted cylinder will have the following gas pressure remaining:



Model Number	Cylinder Pressure	
530 1XXX	1250-1750 PSIG	86-120 BAR
530 2XXX	1800-2300 PSIG	124-159 BAR
530 3XXX	2800-3300 PSIG	193-228 BAR
530 4XXX	3800-4300 PSIG	262-297 BAR

Gas will continue to flow from the primary side until the outlet pressure of the primary regulator matches the pressure setting of the reserve regulator. (The pressure setting of the priority valve regulator changes when the knob is turned 180°). When the gas pressure stops dropping on the primary side regulator and starts to drop on the reserve side regulator, it is time to change the primary cylinder. The knob is rotated 180° to the reserve side changing priority before the depleted cylinder is changed. It is helpful to maintain a log of cylinder pressure, noting which direction the arrow is pointing on the priority valve. When the pressure gauge is very low and the reserve side indicates that gas has begun to flow from the reserve cylinder, it is time to rotate the knob and attach a full cylinder in reserve.

If the knob is not rotated before the empty cylinder is changed, two things can happen. First, gas may flow from the changed cylinder to the existing cylinder. This is because the pressure setting of the regulator on the primary side allows the regulator main valve to remain open. Second, when the cylinder is changed, gas will begin to flow from the new cylinder, stopping flow from the existing cylinder. This means the existing cylinder may be partially empty. After several cycles, it is possible that the reserve cylinder may empty shortly after a switchover occurs. Always remember to rotate the knob on the priority valve regulator **before** changing a depleted cylinder.

## MAINTENANCE

On regular intervals, the system should be checked for leaks and proper function (see trouble shooting). Any leaks in the system should be corrected immediately. The pigtail check valve should also be checked for leaks when a depleted cylinder is removed. **NOTE: the system inlet and pigtail should be pressurized when checking for leaks.** At no time should the preset regulator's or priority valve regulator's pressure settings be changed.

## TROUBLE SHOOTING

Typical symptoms listed below indicate regulator malfunctions needing repair. Replace immediately with a clean, repaired and tested, or new system.

1. Gas leakage at the line regulator outlet when the adjusting screw of the line regulator is completely backed out.
2. With no flow through the system (downstream valves closed and adjusting screw in) line pressure steadily increases above set pressure.
3. Gas leakage from spring case (adjusting screw/knob end of regulator).
4. Gas leakage from any joint.
5. Excessive drop in working pressure with regulator flowing gas.
6. Gas leakage from gauge
7. Gauge does not return to zero when not under gas pressure
8. Gauge does not consistently repeat the same reading.
10. The system makes a noise or hums.

If the switchover system seems to be using gas from the primary **and** reserve cylinders (pressure is decreasing on both inlet gauges at the same time), please contact a CONCOA customer service personnel. Please be prepared to give the following:

- Model number
- Gas service
- Inlet pressure and type of gas supply
- Outlet pressure
- Approximate gas usage

**NOTE: Maximum rated flow for these systems is 4000 SCFH.**

## **SERVICE**

A unit that is not functioning properly should not be used. It is recommended that all servicing be done by a service facility authorized by CONCOA. Contact CONCOA Customer Service in Virginia Beach, Virginia for systems still covered by the warranty. For items not covered by the warranty, contact the nearest CONCOA District Sales Office for assistance.

If so advised, the unit should be sent to a service facility authorized by CONCOA. Do the following before shipping:

1. Adequately package the system. If possible package in the original shipping container.
2. Ship prepaid.
3. Include a statement of the observed deficiency.
4. Indicate the gas service that the equipment was used on.
5. Purge all equipment before shipment to protect the transporter and service personnel. The purging is especially important if the equipment has been in hazardous or corrosive gas service.

Return trip transportation charges are to be paid by the Buyer. In all cases where the warranty has expired, repairs will be made at current list price for the replacement part(s), plus a reasonable labor charge.

# Warranty Information

This equipment is sold by CONTROLS CORPORATION OF AMERICA under the warranties set forth in the following paragraphs. Such warranties are extended only with respect to the purchase of this equipment directly from CONTROLS CORPORATION OF AMERICA or its Authorized Distributors as new merchandise and are extended to the first Buyer thereof other than for the purpose of resale.

For a period of one (1) year from the date of original delivery (90 days in corrosive service) to Buyer or to Buyer's order, this equipment is warranted to be free from functional defects in materials and workmanship and to conform to the description of this equipment contained in this manual and any accompanying labels and/or inserts, provided that the same is properly operated under conditions of normal use and that regular periodic maintenance and service is performed or replacements made in accordance with the instructions provided. The foregoing warranties shall not apply if the equipment has been repaired: other than by CONTROLS CORPORATION OF AMERICA or a designated service facility or in accordance with written instructions provided by CONTROLS CORPORATION OF AMERICA, or altered by anyone other than CONTROLS CORPORATION OF AMERICA, or if the equipment has been subject to abuse, misuse, negligence or accident.

CONTROLS CORPORATION OF AMERICA's sole and exclusive obligation and Buyer's sole and exclusive remedy under the above warranties is limited to repairing or replacing, free of charge, at CONTROLS CORPORATION OF AMERICA's option, the equipment or part, which is reported to its Authorized Distributor from whom purchased, and which if so advised, is returned with a statement of the observed deficiency, and proof of purchase of equipment or part not later than seven (7) days after the expiration date of the applicable warranty, to the nearest designated service facility during normal business hours, transportation charges prepaid, and which upon examination, is found not to comply with the above warranties. Return trip transportation charges for the equipment or part shall be paid by Buyer.

**CONTROLS CORPORATION OF AMERICA SHALL NOT BE OTHERWISE LIABLE FOR ANY DAMAGES INCLUDING BUT NOT LIMITED TO: INCIDENTAL DAMAGES, CONSEQUENTIAL DAMAGES, OR SPECIAL DAMAGES, WHETHER SUCH DAMAGES RESULT FROM NEGLIGENCE, BREACH OF WARRANTY OR OTHERWISE.**

**THERE ARE NO EXPRESS OR IMPLIED WARRANTIES WHICH EXTEND BEYOND THE WARRANTIES HEREINABOVE SET FORTH. CONTROLS CORPORATION OF AMERICA MAKES NO WARRANTY OF MERCHANTABILITY OR FITNESS FOR A PARTICULAR PURPOSE WITH RESPECT TO THE EQUIPMENT OR PARTS THEREOF.**



Controls Corporation of America  
1501 Harpers Road • Virginia Beach, VA 23454  
To Order Call 1-800-225-0473 or 757-422-8330 • Fax 757-422-3125  
[www.concoa.com](http://www.concoa.com)