



IntelliSwitch[™] Electronic Switchover

PATENT PENDING

INSTALLATION AND OPERATING INSTRUCTIONS

Carefully Read These Instructions Before Operating

Controls Corporation of America
1501 Harpers Road • Virginia Beach, VA 23454
To Order Call 1-800-225-0473 or 757-422-8330 • Fax 757-422-3125
www.concoa.com

November 2006
Supersedes March 2006

DESCRIPTION OF PRODUCT

The IntelliSwitch is a device used to monitor, control and switch the flow of gas from cryogenic or high pressure cylinders from either of two independent sources to a single point of use.

It consists of two controllable valves that direct the flow of gas into a delivery regulator.

Pressure coming into the IntelliSwitch is monitored and displayed on two independent 4-digit displays. The outlet pressure of the system is monitored and displayed on a 3-digit display. Outlet pressure adjustment is available using a knob on the front panel.

A series of indicator lights show the status of the system at any given time.

The status of the IntelliSwitch may be monitored remotely via a serial port. In addition, the IntelliSwitch can interface with any of the CONCOA Remote Alarms.

There are two basic models of the IntelliSwitch. One uses the delivery gas to activate the valves used for bank switching. The other uses compressed air or an inert gas to activate the valves used for bank switching.

Each model features several different versions targeted at the pressures and flows of specific applications.

FEATURES

Operation from Multiple Gas Sources

The IntelliSwitch is capable of operating from 230, 350, and 500 PSI liquid cylinders, 3000 and 4500 (641 option only) PSI high pressure cylinders, or any combination.

Look Back

The IntelliSwitch switches from one bank to the other based upon the pressure supplied to the selected bank. When the volume of the liquid in the cylinder becomes low or the gas flow becomes particularly high, it is not uncommon for the pressure to drop below the switching point even if there is plenty of gas left in the cylinder. When a typical switchover enters such a state, two undesirable situations may occur. First, the system may switch to the reserve temporarily until pressure builds on the primary enough to cause the system to switch back. This situation often leads to depleting both sides at the same time as the system rapidly alternates drawing from both sides or even draws both sides at the same time. Second, the system may permanently switch to the reserve leaving unused product in the primary and triggering a false alarm.

To avoid either of these situations, the IntelliSwitch has a Look Back feature that allows the system to switch banks and wait a predetermined time period before checking the former primary cylinder. If the pressure has recovered enough, the system will switch back to the former primary cylinder. This look back time allows the pressure building circuit to recover and build sufficient pressure to supply the system and fully draw down the primary cylinder before an alarm is triggered indicating the cylinder is empty, allowing maximum utilization of cylinder contents.

Switchback Delay

Using the Look Back feature alone can result in the switchover switching back several times well after the cylinder can provide a useful gas supply. To prevent this, the Switchback Delay feature keeps track of how often the IntelliSwitch switches back to a liquid cylinder that has been used and whose pressure has been restored to be used again.

If the system switches away from the priority side before the Switchback Delay timer has timed out, the system determines that all the useful gas has been extracted from the cylinder and switches to the auxiliary side and draws from it.

Hysteresis

This feature is a pressure value added to the switchover pressure value to determine the pressure at which the IntelliSwitch will switch back to a cylinder after the “Look Back” time has expired. This feature provides added protection against inadvertently drawing from the reserve bank when the primary still has gas.

Economizer Function

When using liquid cylinders in switchover application, it is common for the reserve cylinder to build pressure due to the vaporization of liquid within the cylinder. When this pressure reaches the set point of the relief valve on the liquid cylinder, the relief valve will open, venting gas to the atmosphere. The IntelliSwitch constantly monitors the reserve cylinder and, at a predetermined pressure, will change the valving to allow gas from the headspace of the reserve cylinder to feed the system, thus drawing down the pressure in the reserve cylinder. There are three pressure ratings for liquid cylinder relief valves, 230 PSIG, 350 PSIG and 500 PSIG; the IntelliSwitch has predetermined settings for all three types that may be selected on the front panel of the system.

Settable Switchover Pressure

The IntelliSwitch can be configured to switch at pressures ranging from 100 to 500 PSI. This value is factory set but can be changed in the field. To change this value refer to the section on changing the switchover pressure.

Manual Bank Switching

It is possible to manually change the side that gas is being drawn from by pressing the “BANK SELECT” button provided that there is sufficient pressure on the side being switched to.

Selectable Units of Measure

The default units of measure for the IntelliSwitch are PSI. Alternate units of BAR or MPA can be selected by changing internal DIP switch settings. To change units of measure refer to the section on changing units of measure.

Security Lockout

The IntelliSwitch has the ability to electronically lockout the front panel buttons to discourage tampering. The factory default setting is OFF or disabled. Refer to section on Keypad Security Lockout for details.

Alarm Notification

The IntelliSwitch is designed to interface with CONCOA Remote Alarms and comes with the necessary mating connector for their use. Refer to the section on connecting a remote alarm for more information.

Serial Port

The IntelliSwitch is capable of communicating to peripheral equipment via a standard serial port. For more information on the serial port refer to the section on connecting to a serial port.

Burst Disk Overpressure Protection

The IntelliSwitch is equipped with a replaceable burst disk for each bank to protect the system from extreme pressure increases and liquid withdrawal.

NEMA 12 Enclosure

Designed for indoor use that provides a limited degree of protection against falling dirt, circulating dust, fibers and against drippings or indirect light splashing of noncorrosive liquids.

USER RESPONSIBILITY

Service to this product should only be performed by CONCOA or an authorized CONCOA agent. Requests for service may be made through CONCOA CUSTOMER SERVICE at 1-800-225-0473. Written requests may be made using CONCOA's FAX number at 1-757-422-3125 or CONCOA's E-MAIL at info@concoa.com

CONCOA accepts no responsibility for damage or injury if this product is modified in any way.

CONCOA assumes/accepts no liability or responsibility for damage to individuals or equipment that may occur when using this product.

SAFETY

THIS PRODUCT IS NOT INTENDED FOR USE WITH TOXIC GASES, FLAMMABLE GASES OR CORROSIVE GASES.

Basic safety precautions must be followed to reduce the risk of fire, electrical shock or injury.

- Connect the IntelliSwitch to the correct line voltage. A label on the product identifies what voltage it is wired for. CONNECTION TO AN INCORRECT VOLTAGE CAN CAUSE SERIOUS DAMAGE TO THE PRODUCT AND WILL VOID ANY WARRANTY.
- While the IntelliSwitch Switchover is dust and moisture resistant, it is NOT water-proof or completely sealed. It should be installed where it will not be subjected to rain or high concentrations of dust. Never pour or spray liquids directly onto the product.
- Install IntelliSwitch where the ambient temperature range is between 0° F and 140° F.
- Do not install this product in a hazardous environment.
- If product appears damaged in any way, do not use and request service from CONCOA.
- Do not attempt to operate the IntelliSwitch with the front panel off.
- Consult the cylinder distributor for the proper use of cylinders and for any restrictions on their use (such as flow rate and temperature requirements).
- Store cylinders with valve caps screwed on, and chain cylinders to a supporting wall or column.
- Handle cylinders carefully and only with valve caps screwed on. The cap will reduce the chance that the cylinder valve will break off if the cylinder is accidentally dropped or falls over. The cap also protects the cylinder valve from damage to screw threads, which could cause leaky connections.
- All manifolds used with flammable gases should be provided with approved flashback arrestors to stop any burning gas in the pipeline from getting back to the manifold or cylinders.
- No smoking should be permitted near oxygen, nitrous oxide, any other oxidizer, flammable gases, or flammable mixtures, or in areas where cylinders are stored.
- Where an oxidizer (such as nitrous oxide or oxygen) is used, the manifold and cylinders must be kept clean. No oil, grease, or combustible substances should come in contact with oxygen or nitrous oxide storage or handling equipment. Such materials in contact with oxygen or nitrous oxide are readily ignitable and, when ignited, will burn intensely.
- Never lift gas cylinders with a magnetic lifting device.
- Never use an open flame when leak testing.
- Always open valves slowly when high-pressure gases are being used.

- Always be sure that a cylinder contains the correct gas before connecting it to any manifold.
- Always leak-test any manifold or distribution pipeline before using.
- Always be sure that the gas in a pipeline is the correct gas for the intended use.
- Always close all cylinder valves before disconnecting cylinders from a manifold.
- Always remove all empty cylinders from a manifold before connecting full cylinders.
- Always test cylinders to be sure the cylinders are full before connecting to a manifold.

All gas distribution piping systems must meet the appropriate industrial standards for the intended service and must be thoroughly cleaned before using. For the United States, some applicable safety rules and precautions are listed below:

1. American National Standards Institute standard Z49.1, Safety in Welding and Cutting, American Welding Society, 2501 NW Seventh Street, Miami, Florida 33125
2. N.F.P.A. Standard 51, Oxygen-Fuel Gas systems for Welding and Cutting, N.F.P.A., 470 Atlantic Avenue, Boston, Massachusetts 02210
3. N.F.P.A. Standard 51B, Cutting and Welding Processes (same address as #2).
4. CONCOA publication ADE 872, Safety Precautions in Welding and Cutting.
5. Local Ordinances
6. O.S.H.A. Standard 29 CFR
7. C.G.A. Pamphlet C-4, American National Standard Method of Marking Portable Compressed Gas Containers to Identify the Material Contained.
8. C.G.A. Pamphlet G-4, Oxygen – Information on the properties, manufacture, transportation, storage, handling, and use of oxygen.
9. C.G.A. Pamphlet G-4.1, Equipment Cleaned for oxygen service.
10. C.G.A. Pamphlet G-4.4, Industrial Practices for Gaseous Oxygen Transmission and Distribution Piping Systems.
11. C.G.A. Pamphlet G-5, Hydrogen – Information on the properties, manufacture, transportation, storage, handling, and use of hydrogen.
12. C.G.A. Pamphlet G-6, Carbon Dioxide – Information on the properties, manufacture, transportation, storage, handling, and use of carbon dioxide.
13. C.G.A. Pamphlet G-6.1, Standard for Low Pressure Carbon Dioxide Systems at Consumer Sites.
14. C.G.A. Pamphlet P-1, Safe Handling of Compressed Gases in Containers.
15. C.G.A. Safety Bulletin SB-2, Oxygen Deficient Atmospheres.

C.G.A. Pamphlets can be obtained from the Compressed Gas Association, 1235 Jefferson Davis Highway, Arlington, VA 22202-3239, (703) 979-0900. Publications: (703) 979-4341. Fax: (703) 979-0134.

CONNECTING THE INTELLISWITCH

The key to any successful system installation is understanding the application and sizing the components properly.

The inlets and outlet on the IntelliSwitch are 1/2" Female NPT fittings. These fittings have an anti-rotation plate around them to keep them from twisting during installation. However, it is strongly recommended that two wrenches be used when tightening external devices to these fittings.

The IntelliSwitch uses four mounting tabs for mounting to a wall or panel. Refer to Figure 8 for the dimensions of the system. Anchor the IntelliSwitch securely to a wall or panel at a height adequate to conveniently connect a manifold or pigtail.

If using an external air-driven IntelliSwitch, connect the air source to the air inlet on the bottom of the system.

Note: Air used for this system must not contain moisture or oil. Air pressure should be in the range of 65-85 PSIG and must not exceed 100 PSIG.

Figure 1 shows a typical installation.

Once all mechanical connections are made, connect the Remote Alarm, and serial device to the IntelliSwitch.

If using an external air-driven IntelliSwitch, turn the air source on at this time.

Finally connect AC power to the IntelliSwitch. The system is factory set to operate at either 115VAC 60hz or 230 VAC 60hz. Connection of the IntelliSwitch to the incorrect input voltage will damage the product and void any warranty.

Pressurize both sides of the system; if using internal process gas-driven IntelliSwitch, pressurize the right side first. The inlet pressure readings will appear on the two 4-digit displays. If necessary use the Bank Select pushbutton to choose the side considered to be the primary gas source. If gas pressures are on before the system is powered up, the IntelliSwitch will default to the left side as the primary side.

Using the outlet pressure adjustment knob, set the desired delivery pressure. The value will appear on the 3-digit display.

Figure 1

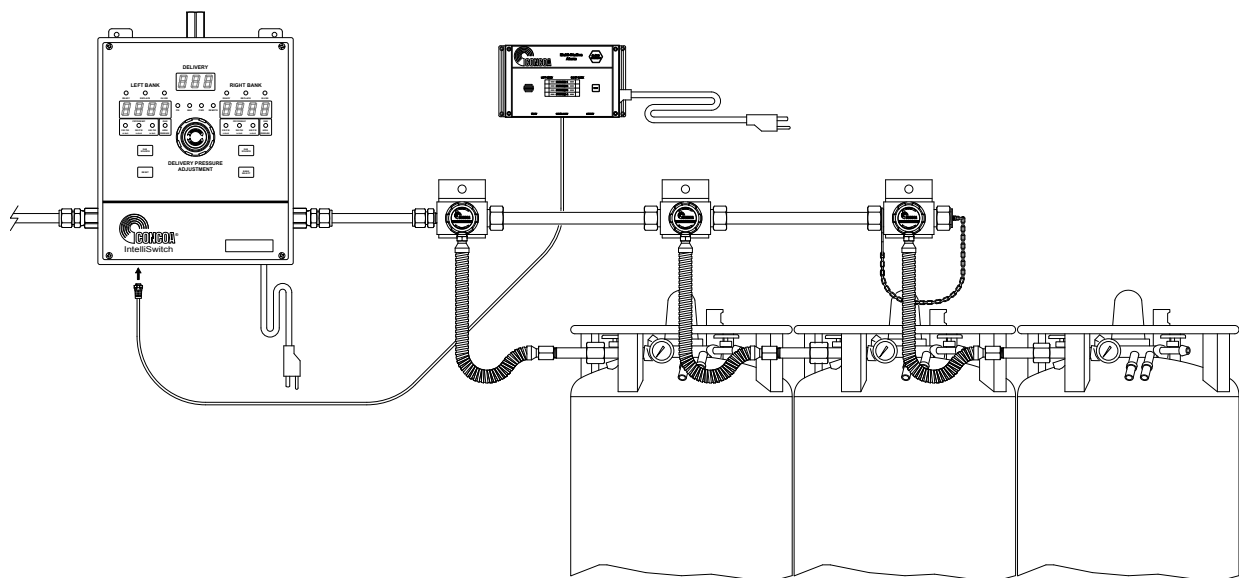

Normal operation of the IntelliSwitch can now begin. The “primary” or “active” side of the system, whether left or right, will have the green Ready light ON and the In Use light ON. The “secondary” side or the “inactive” side will have only the green Ready light ON.

Lighted green lights above the Source Select buttons should match the types of cylinders being used by each side.

All switching is automatic. If the primary side drops below the set switchover point, the system will transfer to the reserve side and the status lights will indicate the transition. The Replace status light and alarm indicate the need to replenish a bank. In the case of high pressure cylinders, the system will reset when pressure has been restored to the depleted bank. In the case of liquid cylinders, the system will reset when both pressure has been restored to the depleted bank and the Reset button has been depressed.

OPERATING THE INTELLISWITCH

Figure 2 identifies and locates the various front panel and external system features.

Selecting a Gas Source

The Source Select buttons on the front panel provide flexibility in the choices of liquid or high pressure cylinders used in an application. Further, they provide choices of liquid cylinders with different pressure ratings. There are two Source Select buttons, allowing each side to be controlled independently. Green indicator lights above the two buttons identify which cylinder choice is currently selected for the side. Each time a Source Select Button is pressed, the indicator lights above the button will shift to the next choice as long as the option is viable given the switchover pressure setting.

Cylinder Sizes

There are three liquid cylinder pressure ratings that can be selected. For each cylinder pressure, the IntelliSwitch has a preset value it uses to determine when the cylinder has reached an overpressure condition. Table 1 provides the cylinder pressure choices.

Table 1 — Cylinder Relief Valve Pressure

Cylinder Relief Valve Pressure
230
350
500

If a liquid cylinder's pressure rises to the "activation" value, the IntelliSwitch will redirect itself to draw the pressure down through the delivery stream. Once the pressure reaches a "normal" value, it will return to drawing from the previous side.

Bank Selection

The Bank Select button on the front panel allows for manually switching the active bank. Status indicator lights provide the feedback to indicate which side is selected.

Reset

The Reset button is primarily used to reset "alarm" or "replace" conditions. The Replace status light can only be cleared if the side with the condition has its pressure restored to a value above the trip point plus the hysteresis value AND the Reset button is pushed. If the button is pushed while the condition still occurs, the system will attempt to clear the alarm but will reinstate the indicators automatically.

Testing

Holding the Reset button in for 5 seconds will place the system in test mode. This diagnostic and troubleshooting tool performs 13 different tests. Each time the Reset button is pushed again, the system will perform a different test. If after the test mode has been entered and there is no pushbutton activity for one minute, the system will return to the normal display operation. Gas flow is maintained during the test mode. Refer to the Troubleshooting Section for details on testing

Keypad Lockout

See Section "User Selectable Features" for explanation on enabling/disabling and using this feature.

Figure 2

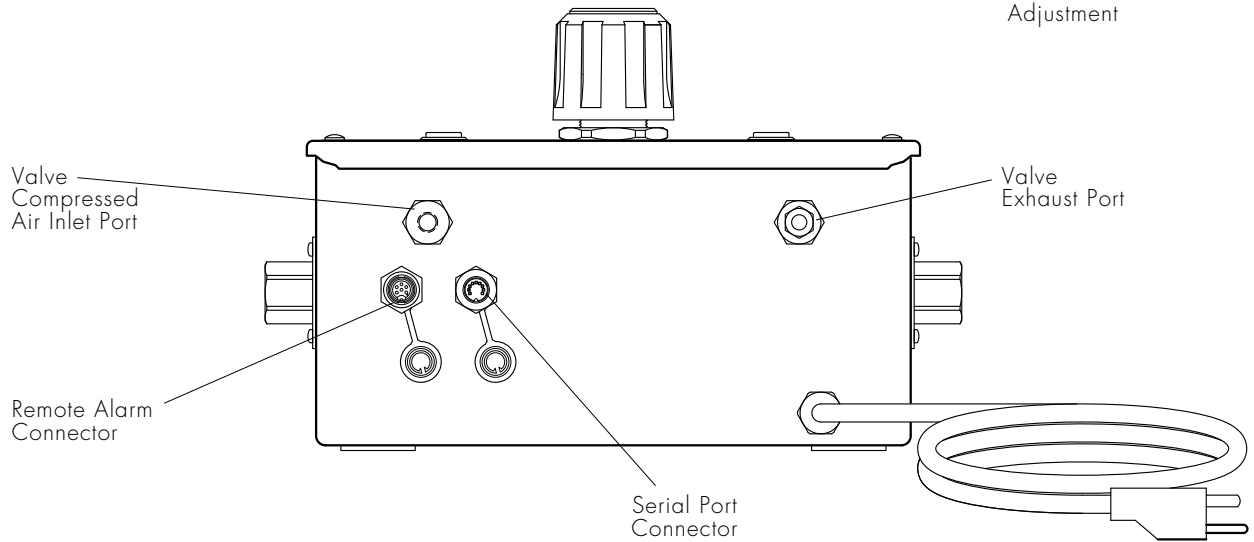
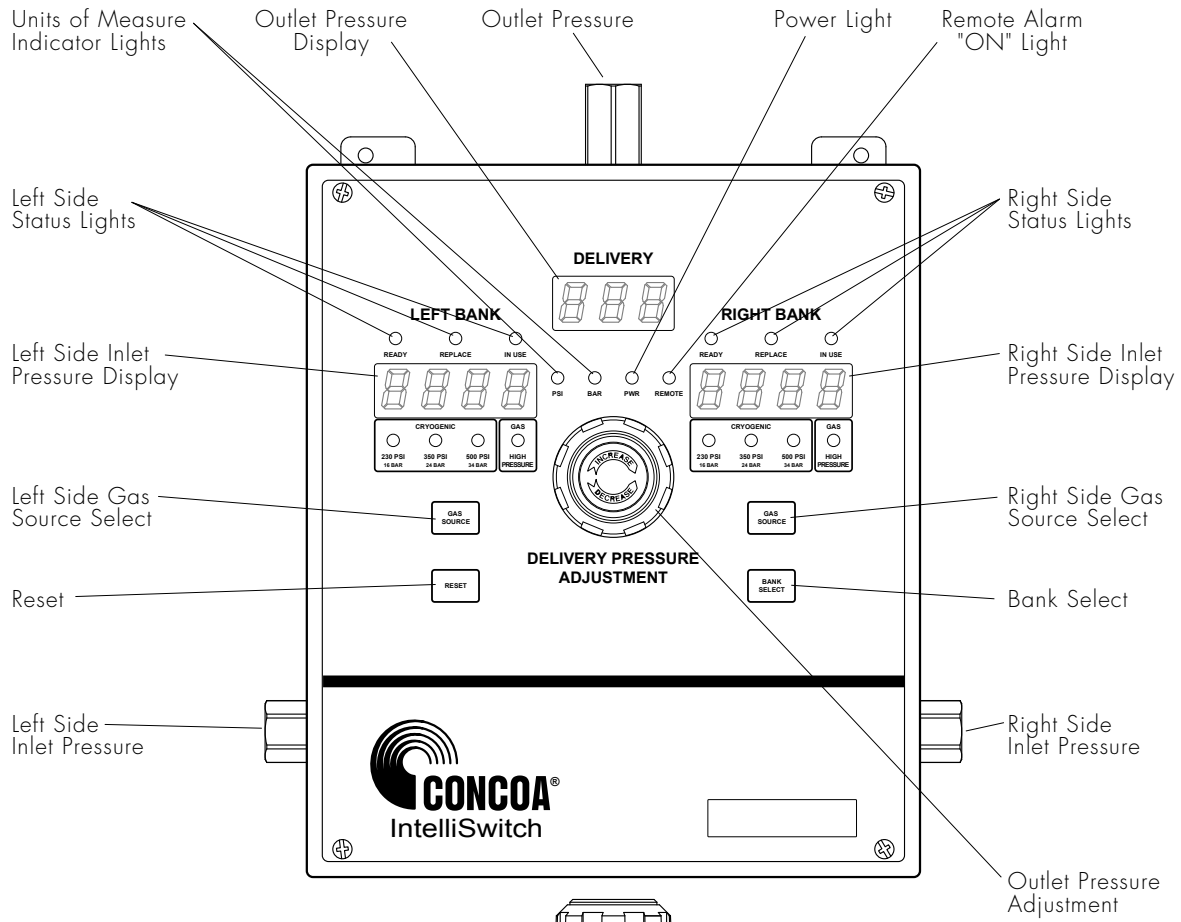

USER SELECTABLE FEATURES

The IntelliSwitch allows various system parameters to be set in the field. They are:

- a. Switchover Pressure
- b. Units of Measure
- c. Keypad Security Lockout
- d. Serial Port Enable

Switchover Pressure

The switchover pressure is factory set to optimize performance based on the outlet pressure range of the system. These factory settings are shown in Table 3 in grey highlight. The switchover pressure can be changed by setting DIP switches SW1-1 through SW1-9 on the Electronic Circuit Board inside the IntelliSwitch. The switchover pressure can be field set up to 500 PSIG. It is important that the switchover pressure be set higher than the desired outlet pressure required by the application, but not higher than the pressure capability of the gas source. Table 3 shows the DIP switch settings to establish the desired switchover value.

To access the DIP switches, REMOVE AC power from the system. Remove the knob on the outlet pressure adjustment regulator by carefully lifting the center label on the knob and removing the nut. Using a Phillips screwdriver, remove the 4 screws and washers holding the front panel. Unscrew the nut on the outlet pressure adjustment regulator being careful not to allow the front panel to fall. There are two long studs attached to the inside of the front panel that will allow hanging of the panel to the bottom of the enclosure.

Table 3 shows some typical switchover settings. To set values other than those in Table 3, use Table 2 or contact CONCOA Customer Service for assistance. Using Table 3 and Figure 3, set the switchover pressure DIP switches to the desired value. When completed, place the front panel back into place being careful not to pinch any wires. Attach the large nut to the Outlet Pressure Adjustment Regulator first. This only needs to be finger tight. Re-install the 4 screws and washers holding the front panel. Attach the knob to the regulator using the nut and reapply the label. The nut holding the knob should be tightened securely.

Re-apply AC power. The new switchover setting may be viewed in test mode.

Note: Table 3 shows values in PSI. To set values in BAR or MPA, convert the numbers in the table. For PSI to BAR, divide the PSI value by 14.5; for PSI to MPA divide the PSI value by 145.

Figure 3

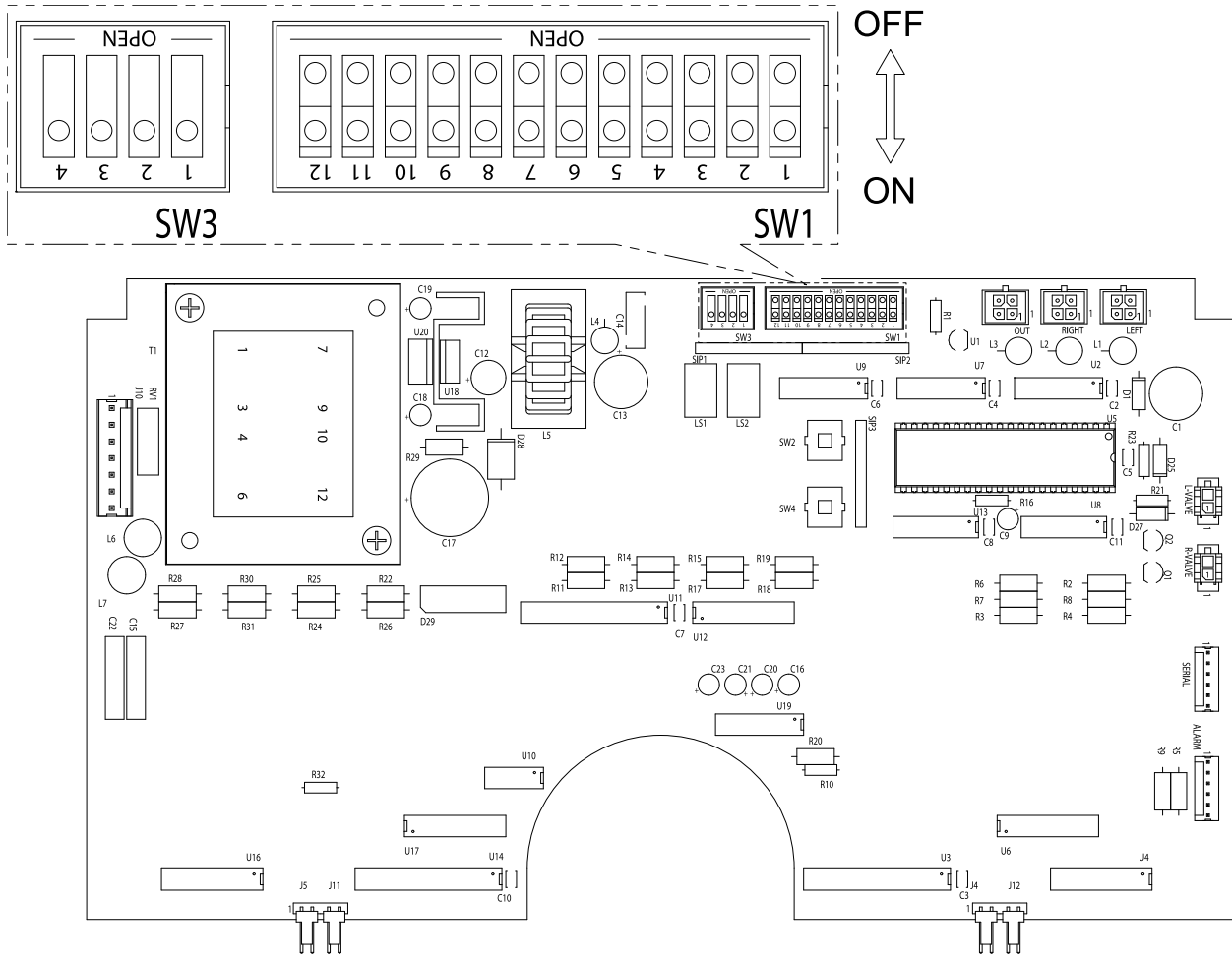

Table 2 – DIP Switch Settings

	Switch #	Function	Value
SW1	1	Switchover pressure set 1	1
	2	Switchover pressure set 2	2
	3	Switchover pressure set 3	4
	4	Switchover pressure set 4	8
	5	Switchover pressure set 5	16
	6	Switchover pressure set 6	32
	7	Switchover pressure set 7	64
	8	Switchover pressure set 8	128
	9	Switchover pressure set 9	256
	10	Reserved	
	11	PSI units set (if SW1-11 and SW2-11 both not set, units = MPA)	ON = set
	12	BAR units set (if SW1-11 and SW2-11 both not set, units = MPA)	ON = set
SW3	1	Serial communication enabled	ON = enabled
	2	Serial communication protocol (RS-232 or RS-485)	ON = RS-485
	3	Reserved	
	4	Keypad lockout	ON = enabled

Table 3 — Typical Switchover Pressure DIP Switch Settings

PSI	SW1-9	SW1-8	SW1-7	SW1-6	SW1-5	SW1-4	SW1-3	SW1-2	SW1-1
75	OFF	OFF	ON	OFF	OFF	ON	OFF	ON	ON
100	OFF	OFF	ON	ON	OFF	OFF	ON	OFF	OFF
125	OFF	OFF	ON	ON	ON	ON	ON	OFF	ON
135	OFF	ON	OFF	OFF	OFF	OFF	ON	ON	ON
150	OFF	ON	OFF	OFF	ON	OFF	ON	ON	OFF
175	OFF	ON	OFF	ON	OFF	ON	ON	ON	ON
200	OFF	ON	ON	OFF	OFF	ON	OFF	OFF	OFF
225	OFF	ON	ON	ON	OFF	OFF	OFF	OFF	ON
250	OFF	ON	ON	ON	ON	ON	OFF	ON	OFF
275	ON	OFF	OFF	OFF	ON	OFF	OFF	ON	ON
300	ON	OFF	OFF	ON	OFF	ON	ON	OFF	OFF
325	ON	OFF	ON	OFF	OFF	OFF	ON	OFF	ON
350	ON	OFF	ON	OFF	ON	ON	ON	ON	OFF
375	ON	OFF	ON	ON	ON	OFF	ON	ON	ON
400	ON	ON	OFF	OFF	ON	OFF	OFF	OFF	OFF
425	ON	ON	OFF	ON	OFF	ON	OFF	OFF	ON
450	ON	ON	ON	OFF	OFF	OFF	OFF	ON	OFF
475	ON	ON	ON	OFF	ON	ON	OFF	ON	ON
500	ON	ON	ON	ON	ON	OFF	ON	OFF	OFF

Units of Measure

The IntelliSwitch is capable of displaying pressure in PSI, BAR or MPA. The units of measure are factory set to PSI. Units of measure may be changed by setting DIP Switches 11 and 12 on the electronic circuit board inside the system.

To access the DIP switches, REMOVE AC power from the system. Remove the knob on the outlet pressure adjustment regulator by carefully lifting the center label on the knob and removing the nut. Using a Phillips screwdriver, remove the 4 screws and washers holding the front panel. Unscrew the nut on the outlet pressure adjustment regulator being careful not to allow the front panel to fall. There are two long studs attached to the inside of the front panel that will allow hanging of the panel to the bottom of the enclosure.

Using Table 4 and Figure 3, set the switchover pressure DIP switches to the desired value. When completed, place the front panel back into place being careful not to pinch any wires. Attach the large nut to the outlet pressure adjustment regulator first. This only needs to be finger tight. Re-install the 4 screws and washers holding the front panel. Attach the knob to the regulator using the nut and reapply the label. The nut holding the knob should be tightened securely.

Re-apply AC power.

Table 4 — Units of Measure

Units of Measure	SW1-11	SW1-12
PSI	ON	OFF
BAR	OFF	ON
MPA	OFF	OFF

The indicator lights on the front panel will show the units selected. For PSI and BAR the light will be ON. If MPA is selected neither the PSI or BAR light are ON signifying MPA.

Keypad Security Lockout

The IntelliSwitch has a built in feature that allows a user to lock the buttons on the front panel so the current setting cannot be changed. The factory default setting for this feature is disabled. This feature can be enabled by setting DIP Switch SW3-4 to “ON”. With the feature enabled and the system turned ON, the system starts a 5-minute timer. If no button is pressed for 5 minutes, an audible beep will sound 3 times after which the buttons will become inactive. To re-activate the buttons, the BANK SELECT button must be depressed for 5 seconds. After 5 seconds, the system will beep 3 times and the buttons will again be active.

To access the DIP switches, REMOVE AC power from the system. Remove the knob on the outlet pressure adjustment regulator by carefully lifting the center label on the knob and removing the nut. Using a Phillips screwdriver, remove the 4 screws and washers holding the front panel. Unscrew the nut on the outlet pressure adjustment regulator being careful not to allow the front panel to fall. There are two long studs attached to the inside of the front panel that will allow hanging of the panel to the bottom of the enclosure.

Using Table 5 and Figure 4, set the switchover pressure DIP switches to the desired value. When completed, place the front panel back into place being careful not to pinch any wires. Attach the large nut to the outlet pressure adjustment regulator first. This only needs to be finger tight. Re-install the 4 screws and washers holding the front panel. Attach the knob to the regulator using the nut and reapply the label. The nut holding the knob should be tightened securely.

Re-apply AC power. The new setting may be viewed in test mode.

Table 5 — Keypad Security Lockout

Function	SW3-4
Lockout Enabled	ON
Lockout Disabled	OFF

Serial Port Enable

The IntelliSwitch is configured at the factory with the serial communication enabled. Serial communication can be disabled by turning DIP Switch SW3-1 “OFF”

To access the DIP switches, REMOVE AC power from the system. Remove the knob on the outlet pressure adjustment regulator by carefully lifting the center label on the knob and removing the nut. Using a Phillips screwdriver, remove the 4 screws and washers holding the front panel. Unscrew the nut on the outlet pressure adjustment regulator being careful not to allow the front panel to fall. There are two long studs attached to the inside of the front panel that will allow hanging of the panel to the bottom of the enclosure.

Using Table 6 and Figure 4, set the switchover pressure DIP switches to the desired value. When completed, place the front panel back into place being careful not to pinch any wires. Attach the large nut to the outlet pressure adjustment regulator first. This only needs to be finger tight. Re-install the 4 screws and washers holding the front panel. Attach the knob to the regulator using the nut and reapply the label. The nut holding the knob should be tightened securely.

Re-apply AC power. The new setting may be viewed in test mode.

Table 6 — Serial Port

Function	SW3-1
Serial Port Enabled	ON
Serial Port Disabled	OFF

CONNECTING TO A REMOTE ALARM

The IntelliSwitch is capable of interfacing to any of CONCOA's Remote Alarms. The 6-pin remote alarm interface connector is located at the bottom of the IntelliSwitch cabinet (See Figure 1). There are two ways to connect the product to an alarm. The first is to build a cable assembly. For convenience, a mating 6-pin connector is provided to use in building this cable assembly. The Remote Alarm comes with a mating connector that is used to attach to the remote alarm side of the cable assembly. The recommended cable for this assembly is 22 AWG, 4-conductor stranded wire (Alpha # 1174C or equivalent). The length of this cable should be limited to 1500 feet. It is also possible to purchase a ready-made cable assembly. Contact your local CONCOA Distributor or call 1-800-225-0473 for information.

Cut the 4-conductor cable to length. Remove the outer jacket of the cable to expose approximately 3/4 inch of the internal conductors on both sides of the cable. Strip away 1/4-inch of the insulation on each of the conductors.

On the 6-pin connector, slide the protective cover, cable retainer, and locking nut over the end of the cable as shown in Figure 4.

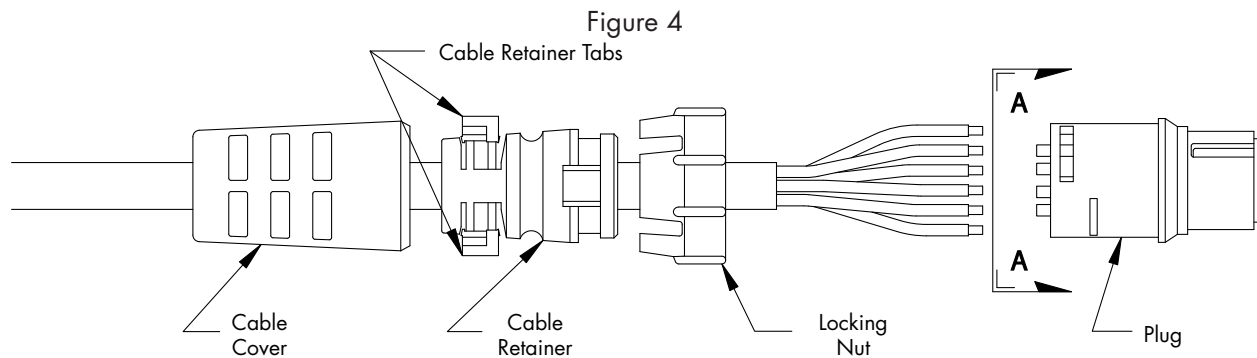

Using the pin assignments shown in Table 7 and the connector views in Figure 4 and Figure 5, solder the wires to the appropriate pins. After soldering is complete, slide the locking nut over the connector body. Snap the cable retainer into the body and then slide the protective cover over the cable retainer.

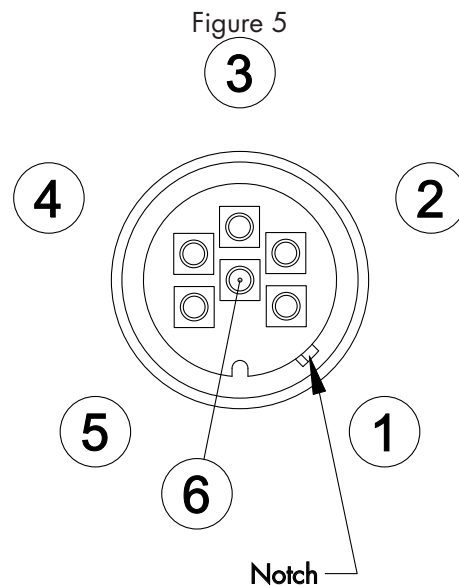

Rear view of 6-pin connector.
View is from the wire side of the connector.

Table 7 — Remote Alarm Pin Assignments

IntelliSwitch Pin Number	529-5106 Alarm Pin Number	529-5310 Alarm Pin Number	Function
1	1	14	Left Alarm Status
2	—	—	N.C.
3	3	3	+12v (provided by the remote alarm)
4	4	15	Right Alarm Status
5	—	—	N.C.
6	6	16	Ground (provided by the remote alarm)

If the IntelliSwitch is being connected to a 529-5106 Alarm, the pin connectors and procedure for the Alarm side of the cable are the same as described above. If the IntelliSwitch is being connected to a 529-5310 or 5295311 Alarm follow the instructions below.

Using the pin assignments shown in Table 7 and the connector views in Figure 6 and Figure 7, solder the wires to the appropriate pins. After soldering is complete, attach the connector cover to the 25 pin connector. Insert the small screws that come with the connector into the holes on the ears of the connector so that the heads of the screws face the wire side of the connector. Slide the retainer clips onto the ears of the connector to capture the screws.

Note: The pin outs shown for the 25-pin connector assume connection to channel 1 of the Alarm. Refer to the appropriate Alarm documentation for connections other than channel 1.

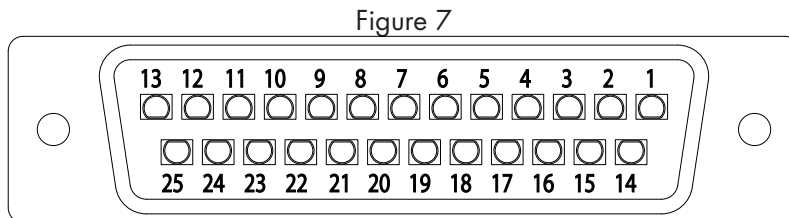
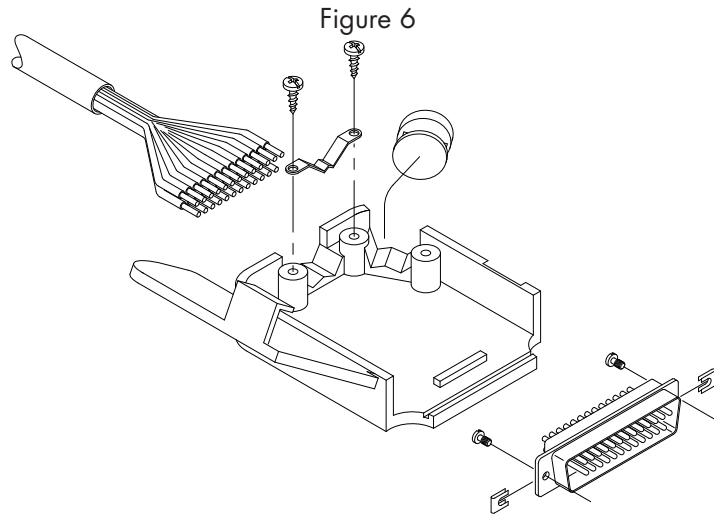

Rear View of 25-pin connector.
View is from the wire side of the connector

CONNECTING TO A SERIAL PORT

The IntelliSwitch is equipped with a serial port. This port is typically configured as an RS-232 Port but can be factory configured as an RS-485 Port.

The Serial Port is used to communicate with external serial devices, primarily a PC. There are a number of commands as well as data that can be communicated between the IntelliSwitch and the peripheral device. Contact your CONCOA representative for more information.

TROUBLESHOOTING

Symptom	Possible Cause	Possible Solution
No display or status lights ON.	<ul style="list-style-type: none"> No power to the system. Check that the power source is live. Check the system fuse. 	<ul style="list-style-type: none"> Restore power. Replace fuse. Replace electronic control board.
System will not switch from one side to the other automatically.	<ul style="list-style-type: none"> Check that the pressure on the destination side is greater than the switchover pressure setting. 	<ul style="list-style-type: none"> Restore pressure to proper operating level. Check that the switchover pressure setting is correct for the cylinder size and inlet pressures required.
There are pressure readings on both inlet displays but no delivery pressure.	<ul style="list-style-type: none"> Air supply is off or its pressure is too low. Internal regulator for the valve system is plugged or faulty 	<ul style="list-style-type: none"> Restore pressure Clean or replace internal regulator
There is a pressure reading on the left inlet display and no pressure on the right inlet display or outlet display.	<ul style="list-style-type: none"> In a system using delivery process gas activation, the right side must be pressurized for gas delivery. 	<ul style="list-style-type: none"> Restore a minimum of 80 PSI pressure to the right side.
Remote alarm does not work with the system.	<ul style="list-style-type: none"> Remote alarm is not powered. Wiring between the IntelliSwitch and the alarm is incorrect. 	<ul style="list-style-type: none"> Check the remote alarm LED on IntelliSwitch front panel. Check alarm is powered and on. Check wiring between alarm and IntelliSwitch
Outlet pressure from the system drops below the adjusted value.	<ul style="list-style-type: none"> Flow demands on the system are greater than the cylinders can supply. Cylinder pressures are too low. Switchover pressure set too low for the application. 	<ul style="list-style-type: none"> Replace or resize cylinders. Change switchover pressure on IntelliSwitch.
Gas from one side appears to be flowing to the other.	<ul style="list-style-type: none"> Dirty or bad check valve. 	<ul style="list-style-type: none"> Replace check valve.
Gas escaping from side of regulator block.	<ul style="list-style-type: none"> Failed burst disk. 	<ul style="list-style-type: none"> Replace burst disk.
Inlet display shows "Err2"	<ul style="list-style-type: none"> Inlet pressure greater than maximum inlet operating pressure. 	<ul style="list-style-type: none"> Reduce pressure to the inlet to maximum allowable.
Outlet display shows "Err2"	<ul style="list-style-type: none"> Outlet regulator failure. 	<ul style="list-style-type: none"> Replace outlet regulator.
Any display shows "Err3"	<ul style="list-style-type: none"> Switchover pressure value is greater than the cylinder size selected. 	<ul style="list-style-type: none"> Change cylinder size by pressing the "Source Select" button Change switchover pressure value.

PERFORMING SELF TEST

Through the use of the Reset button on the front panel, a number of items can be observed or analyzed. A number 1 - 13 which is displayed on the output pressure display identifies each test. To enter Test Mode press and hold the Reset button for 4 seconds. The system will beep 3 times and then enter Test Mode. A description of the tests follows.

“Reset” button pushed first time — Enter “Test” Mode and...

1. [TEST 1] Display Test — This test exercises all segments of the displays and all status lights except the power and remote alarm indication. If serial communication is selected, the system will output a code indicating that a self-test is being performed.

Next “Reset” button

2. [TEST 2] Display Date of Manufacture — The year of manufacture will be shown on the left inlet display and the month and day, respectively, of manufacture will be shown on the right inlet display.

Next “Reset” button

3. [TEST 3] Display Software Revision — The number on the left inlet display is the software revision the product is running. This should appear as a 3 digit number. Example: 137 is version 1.37.

Next “Reset” button

4. [TEST 4] Transducer Test — This test checks to determine if the transducer input channels are working. If they are working correctly, a value between 475 and 525 should appear on the three displays.

Next “Reset” button

5. [TEST 5] Turn ON Left Side Valve — This test forces the valve that controls flow from the left inlet to ON. This helps determine if there is gas flow from the left side. If gas is not flowing during this test, check that the cylinder(s) is turned on and full of gas. If there is gas, and the cylinder is turned on, it may be possible that the left side is plugged.

Next “Reset” button

6. [TEST 6] Turn ON Right Side Valve — This test forces the valve that controls flow from the right inlet to ON. This helps determine if there is gas flow from the right side. If gas is not flowing during this test, check that the cylinder(s) is turned on and full of gas. If there is gas, and the cylinder is turned on, it may be possible that the left side is plugged.

Next “Reset” button

7. [TEST 7] Turn ON Left Side Alarm — Activating this test should cause a connected remote alarm to show an alarm on the left side. If it does not, check the wiring to the alarm and the alarm’s power.

Next “Reset” button

8. [TEST 8] Turn ON Right Side Alarm — Activating this test should cause a connected remote alarm to show an alarm on the right side. If it does not, check the wiring to the alarm and the alarm’s power.

Next “Reset” button

9. [TEST 9] Display DIP Switch Settings — This test shows the settings of the internal DIP switches on the electronics circuit board. The left inlet display will show the switchover pressure in PSI. The right side 4 digit display will show the other switch settings including units of measure, serial port enable and security lockout.

If the switchover pressure needs to be changed, refer to the section on switchover pressure settings for instruction.

The right inlet display shows the settings of the auxiliary DIP switches including the units of measure, Serial Port Enable, and Security Lockout. To determine how these switches are set, refer to Table 9. Find the decimal number in the table in the left column. Find the columns to the right of the decimal number that say “ON”. Follow that column to the top of the table to determine what functions are enabled. To change these settings refer to section on user selectable features.

Next “Reset” button

10. [TEST 10] Button Test — This test checks that each button is functioning. The right inlet display will blank and the left inlet display will change its digits when the keys are pressed. Table 8 shows the number that will appear on the left inlet display when pressed and working properly. Pushing the Reset button will increment to the next test so it will not display a number.

Table 8 — Test 10

Button	Display
Left Source	0001
Right Source	0010
Bank Select	0100

Next “Reset” button

11. [TEST 11] Display Look Back Time Delay — The value shown on the left inlet display represents the time in minutes the IntelliSwitch allows a liquid cylinder to recover its pressure to a predetermined value (Hysteresis Pressure) above the set switchover pressure point (as viewed in Test 9). This number is factory set between 0 and 60 minutes.

Next “Reset” button

12. [TEST 12] Display Switchback Delay Time — The left inlet display will show a time in minutes. When the IntelliSwitch switches back to a side that has recovered sufficient pressure after a look back time, a timer set to the minutes in the display will start. If the side loses pressure and switches again before this time expires, it is interpreted as having insufficient pressure and the system will alarm. This number is factory set between 1 and 60 minutes.

Next “Reset” button

13. [TEST 13] Display Hysteresis Pressure — The left inlet display will show a pressure in PSI that represents the amount of pressure above the switchover pressure point that is used to determine when a side is ready to use again.
14. [TEST 14] Display Calibration Values — The left inlet display will show a number that represents the internal calibration value for the left transducer. The right inlet display will show a number that represents the internal calibration value for the right transducer. These are factory set.

Next “Reset” button

End Test Mode — Restores displays and places the system back into normal operating mode.

Table 9 — DIP Switch Settings

Display Number	Security Lockout	Reserved	RS-485 selected	Serial Enabled	BAR	PSI	Reserved
	SW3				SW1		
	DIP Switch Position						
	4	3	2	1	12	11	10
0	OFF	OFF	OFF	OFF	OFF	OFF	OFF
1	OFF	OFF	OFF	OFF	OFF	OFF	ON
2	OFF	OFF	OFF	OFF	OFF	ON	OFF
3	OFF	OFF	OFF	OFF	OFF	ON	ON
4	OFF	OFF	OFF	OFF	ON	OFF	OFF
5	OFF	OFF	OFF	OFF	ON	OFF	ON
8	OFF	OFF	OFF	ON	OFF	OFF	OFF
9	OFF	OFF	OFF	ON	OFF	OFF	ON
10	OFF	OFF	OFF	ON	OFF	ON	OFF
11	OFF	OFF	OFF	ON	OFF	ON	ON
12	OFF	OFF	OFF	ON	ON	OFF	OFF
13	OFF	OFF	OFF	ON	ON	OFF	ON
24	OFF	OFF	ON	ON	OFF	OFF	OFF
25	OFF	OFF	ON	ON	OFF	OFF	ON
26	OFF	OFF	ON	ON	OFF	ON	OFF
27	OFF	OFF	ON	ON	OFF	ON	ON
28	OFF	OFF	ON	ON	ON	OFF	OFF
29	OFF	OFF	ON	ON	ON	OFF	ON
32	OFF	ON	OFF	OFF	OFF	OFF	OFF
33	OFF	ON	OFF	OFF	OFF	OFF	ON
34	OFF	ON	OFF	OFF	OFF	ON	OFF
35	OFF	ON	OFF	OFF	OFF	ON	ON
36	OFF	ON	OFF	OFF	ON	OFF	OFF
37	OFF	ON	OFF	OFF	ON	OFF	ON
40	OFF	ON	OFF	ON	OFF	OFF	OFF
41	OFF	ON	OFF	ON	OFF	OFF	ON
42	OFF	ON	OFF	ON	OFF	ON	OFF
43	OFF	ON	OFF	ON	OFF	ON	ON
44	OFF	ON	OFF	ON	ON	OFF	OFF
45	OFF	ON	OFF	ON	ON	OFF	ON
56	OFF	ON	ON	ON	OFF	OFF	OFF
57	OFF	ON	ON	ON	OFF	OFF	ON
58	OFF	ON	ON	ON	OFF	ON	OFF
59	OFF	ON	ON	ON	OFF	ON	ON
60	OFF	ON	ON	ON	ON	OFF	OFF
61	OFF	ON	ON	ON	ON	OFF	ON

Display Number	Security Lockout	Reserved	RS-485 selected	Serial Enabled	BAR	PSI	Reserved
	SW3				SW1		
	DIP Switch Position						
	4	3	2	1	12	11	10
64	ON	OFF	OFF	OFF	OFF	OFF	OFF
65	ON	OFF	OFF	OFF	OFF	OFF	ON
66	ON	OFF	OFF	OFF	OFF	ON	OFF
67	ON	OFF	OFF	OFF	OFF	ON	ON
68	ON	OFF	OFF	OFF	ON	OFF	OFF
69	ON	OFF	OFF	OFF	ON	OFF	ON
72	ON	OFF	OFF	ON	OFF	OFF	OFF
73	ON	OFF	OFF	ON	OFF	OFF	ON
74	ON	OFF	OFF	ON	OFF	ON	OFF
75	ON	OFF	OFF	ON	OFF	ON	ON
76	ON	OFF	OFF	ON	ON	OFF	OFF
77	ON	OFF	OFF	ON	ON	OFF	ON
88	ON	OFF	ON	ON	OFF	OFF	OFF
89	ON	OFF	ON	ON	OFF	OFF	ON
90	ON	OFF	ON	ON	OFF	ON	OFF
91	ON	OFF	ON	ON	OFF	ON	ON
92	ON	OFF	ON	ON	ON	OFF	OFF
93	ON	OFF	ON	ON	ON	OFF	ON
96	ON	ON	OFF	OFF	OFF	OFF	OFF
97	ON	ON	OFF	OFF	OFF	OFF	ON
98	ON	ON	OFF	OFF	OFF	ON	OFF
99	ON	ON	OFF	OFF	OFF	ON	ON
100	ON	ON	OFF	OFF	ON	OFF	OFF
101	ON	ON	OFF	OFF	ON	OFF	ON
104	ON	ON	OFF	ON	OFF	OFF	OFF
105	ON	ON	OFF	ON	OFF	OFF	ON
106	ON	ON	OFF	ON	OFF	ON	OFF
107	ON	ON	OFF	ON	OFF	ON	ON
108	ON	ON	OFF	ON	ON	OFF	OFF
109	ON	ON	OFF	ON	ON	OFF	ON
112	ON	ON	ON	ON	OFF	OFF	OFF
113	ON	ON	ON	ON	OFF	OFF	ON
114	ON	ON	ON	ON	OFF	ON	OFF
115	ON	ON	ON	ON	OFF	ON	ON
124	ON	ON	ON	ON	ON	OFF	OFF
125	ON	ON	ON	ON	ON	OFF	ON

MOUNTING DETAIL

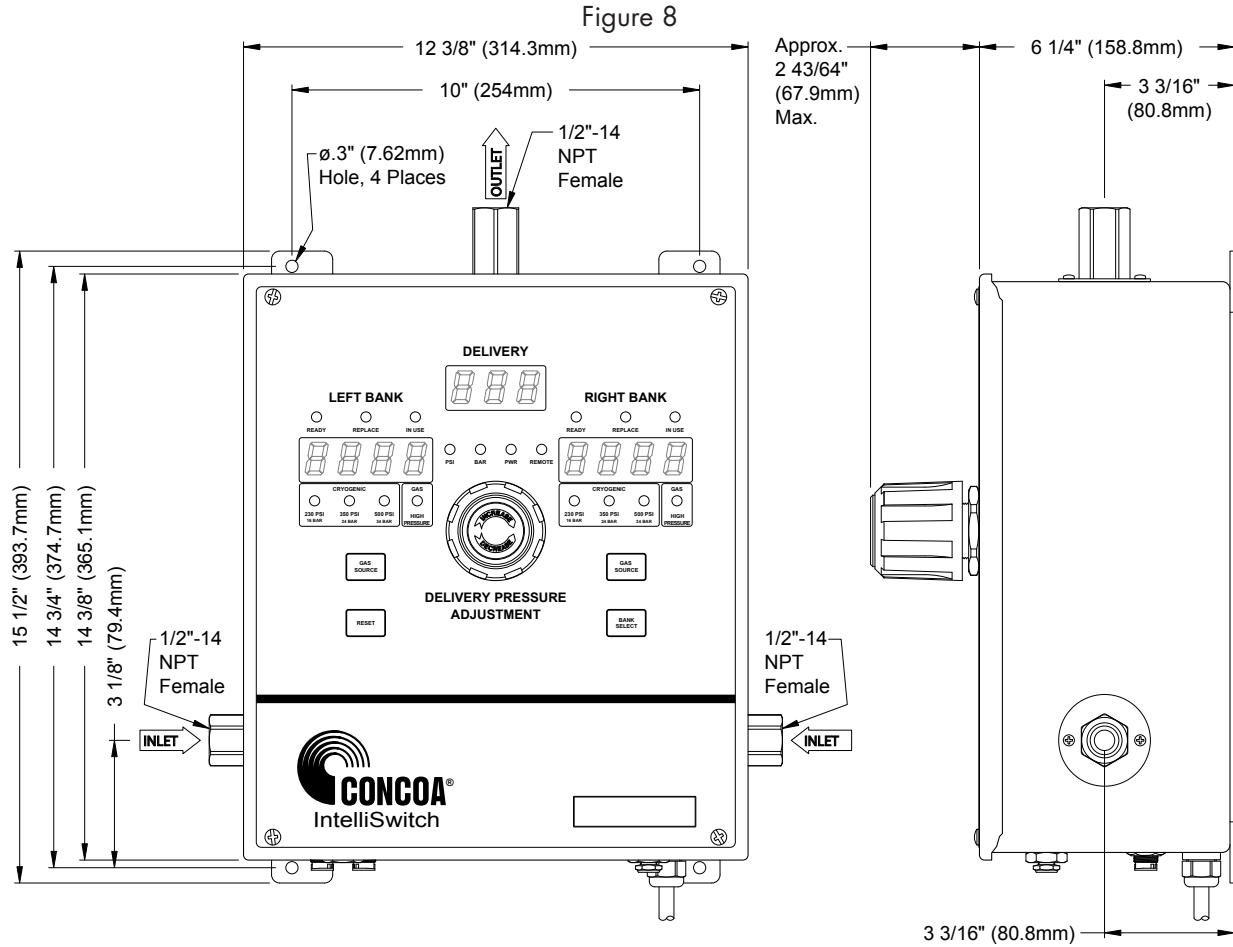

POWER REQUIREMENTS

Input Voltage: 115 VAC \pm 10% 50-60hz or 230 VAC \pm 10% 50-60hz

Power Consumption: 20 watts

Fuse: 1 amp, type 3AG normal blow

SERVICE

For Service to the IntelliSwitch contact your local Distributor or CONCOA Customer Service at 1-800-225-0473. Please fill in the Self Test Worksheet form included in this manual before contacting CONCOA for assistance. This will ensure a more timely response to your needs. An example of how to fill in the sheet is shown in Figure 9.

Figure 9

2	Date of Manufacture	<div style="display: flex; justify-content: center; gap: 10px;"> <div style="display: flex; gap: 5px;"> <input type="text"/> <input type="text"/> <input type="text"/> 2 </div> <div style="display: flex; gap: 5px;"> <input type="text"/> 2 <input type="text"/> 0 <input type="text"/> 0 <input type="text"/> 4 </div> <div style="display: flex; gap: 5px;"> <input type="text"/> 1 <input type="text"/> 2 <input type="text"/> 2 <input type="text"/> 5 </div> </div>
---	------------------------	--

SELF TEST WORKSHEET

Test #	Test Description	Display Data
1	Display Test	All Display Segments OK? <input type="checkbox"/> YES <input type="checkbox"/> NO All Indicator Lights OK? <input type="checkbox"/> YES <input type="checkbox"/> NO
2	Date of Manufacture	<div style="text-align: center;"> <input type="checkbox"/><input type="checkbox"/><input type="checkbox"/> <input type="checkbox"/><input type="checkbox"/><input type="checkbox"/><input type="checkbox"/> <input type="checkbox"/><input type="checkbox"/><input type="checkbox"/><input type="checkbox"/> </div>
3	Software Revision	<div style="text-align: center;"> <input type="checkbox"/><input type="checkbox"/><input type="checkbox"/> <input type="checkbox"/><input type="checkbox"/><input type="checkbox"/><input type="checkbox"/> <input type="checkbox"/><input type="checkbox"/><input type="checkbox"/><input type="checkbox"/> </div>
4	Transducer Test	<div style="text-align: center;"> <input type="checkbox"/><input type="checkbox"/><input type="checkbox"/> <input type="checkbox"/><input type="checkbox"/><input type="checkbox"/><input type="checkbox"/> <input type="checkbox"/><input type="checkbox"/><input type="checkbox"/><input type="checkbox"/> </div>
9	DIP Switch Value	<div style="text-align: center;"> <input type="checkbox"/><input type="checkbox"/><input type="checkbox"/> <input type="checkbox"/><input type="checkbox"/><input type="checkbox"/><input type="checkbox"/> <input type="checkbox"/><input type="checkbox"/><input type="checkbox"/><input type="checkbox"/> </div>
10	Button Test	<div style="text-align: center;"> <input type="checkbox"/><input type="checkbox"/><input type="checkbox"/> Left Source Select <input type="checkbox"/><input type="checkbox"/><input type="checkbox"/><input type="checkbox"/> <input type="checkbox"/><input type="checkbox"/><input type="checkbox"/><input type="checkbox"/> Right Source Select <input type="checkbox"/><input type="checkbox"/><input type="checkbox"/><input type="checkbox"/> <input type="checkbox"/><input type="checkbox"/><input type="checkbox"/><input type="checkbox"/> Bank Select <input type="checkbox"/><input type="checkbox"/><input type="checkbox"/><input type="checkbox"/> <input type="checkbox"/><input type="checkbox"/><input type="checkbox"/><input type="checkbox"/> </div>
11	Look Back Delay Value	<div style="text-align: center;"> <input type="checkbox"/><input type="checkbox"/><input type="checkbox"/> <input type="checkbox"/><input type="checkbox"/><input type="checkbox"/><input type="checkbox"/> <input type="checkbox"/><input type="checkbox"/><input type="checkbox"/><input type="checkbox"/> </div>
12	Hysteresis Pressure Value	<div style="text-align: center;"> <input type="checkbox"/><input type="checkbox"/><input type="checkbox"/> <input type="checkbox"/><input type="checkbox"/><input type="checkbox"/><input type="checkbox"/> <input type="checkbox"/><input type="checkbox"/><input type="checkbox"/><input type="checkbox"/> </div>
13	Look Back Frequency Value	<div style="text-align: center;"> <input type="checkbox"/><input type="checkbox"/><input type="checkbox"/> <input type="checkbox"/><input type="checkbox"/><input type="checkbox"/><input type="checkbox"/> <input type="checkbox"/><input type="checkbox"/><input type="checkbox"/><input type="checkbox"/> </div>
14	Calibration Values	<div style="text-align: center;"> <input type="checkbox"/><input type="checkbox"/><input type="checkbox"/> <input type="checkbox"/><input type="checkbox"/><input type="checkbox"/><input type="checkbox"/> <input type="checkbox"/><input type="checkbox"/><input type="checkbox"/><input type="checkbox"/> </div>

WARRANTY INFORMATION

This equipment is sold by CONTROLS CORPORATION OF AMERICA under the warranties set forth in the following paragraphs. Such warranties are extended only with respect to the purchase of this equipment directly from CONTROLS CORPORATION OF AMERICA or its Authorized Distributors as new merchandise and are extended to the first Buyer thereof other than for the purpose of resale.

For a period of one (1) year from the date of original delivery (90 days in corrosive service) to Buyer or to Buyer's order, this equipment is warranted to be free from functional defects in materials and workmanship and to conform to the description of this equipment contained in this manual and any accompanying labels and/or inserts, provided that the same is properly operated under conditions of normal use and that regular periodic maintenance and service is performed or replacements made in accordance with the instructions provided. The foregoing warranties shall not apply if the equipment has been repaired: other than by CONTROLS CORPORATION OF AMERICA or a designated service facility or in accordance with written instructions provided by CONTROLS CORPORATION OF AMERICA, or altered by anyone other than CONTROLS CORPORATION OF AMERICA, or if the equipment has been subject to abuse, misuse, negligence or accident.

CONTROLS CORPORATION OF AMERICA's sole and exclusive obligation and Buyer's sole and exclusive remedy under the above warranties is limited to repairing or replacing, free of charge, at CONTROLS CORPORATION OF AMERICA's option, the equipment or part, which is reported to its Authorized Distributor from whom purchased, and which if so advised, is returned with a statement of the observed deficiency, and proof of purchase of equipment or part not later than seven (7) days after the expiration date of the applicable warranty, to the nearest designated service facility during normal business hours, transportation charges prepaid, and which upon examination, is found not to comply with the above warranties. Return trip transportation charges for the equipment or part shall be paid by Buyer.

CONTROLS CORPORATION OF AMERICA SHALL NOT BE OTHERWISE LIABLE FOR ANY DAMAGES INCLUDING BUT NOT LIMITED TO: INCIDENTAL DAMAGES, CONSEQUENTIAL DAMAGES, OR SPECIAL DAMAGES, WHETHER SUCH DAMAGES RESULT FROM NEGLIGENCE, BREACH OF WARRANTY OR OTHERWISE.

THERE ARE NO EXPRESS OR IMPLIED WARRANTIES WHICH EXTEND BEYOND THE WARRANTIES HEREINABOVE SET FORTH. CONTROLS CORPORATION OF AMERICA MAKES NO WARRANTY OF MERCHANTABILITY OR FITNESS FOR A PARTICULAR PURPOSE WITH RESPECT TO THE EQUIPMENT OR PARTS THEREOF.

THIS PAGE INTENTIONALLY LEFT BLANK



Controls Corporation of America
1501 Harpers Road Virginia Beach, VA 23454
To Order Call 1-800-225-0473 or 757-422-8330 • Fax 757-422-3125
www.concoa.com