



Advantium Rx Alarm

INSTALLATION AND OPERATING INSTRUCTIONS

Carefully Read These Instructions Before Operating

Controls Corporation of America
1501 Harpers Road • Virginia Beach, VA 23454
Telephone 1-800-225-0473 or 757-422-8330 • Fax 757-422-3125
www.concoa.com

November 2009
Revision B

SAFETY



BASIC SAFETY PRECAUTIONS MUST BE FOLLOWED TO REDUCE THE RISK OF FIRE, ELECTRICAL SHOCK OR INJURY.

- Connect the Advantium Rx to the correct line voltage. A label on the product identifies what voltage it is wired for. CONNECTION TO AN INCORRECT VOLTAGE CAN CAUSE SERIOUS DAMAGE TO THE PRODUCT AND WILL VOID ANY WARRANTY.
- While the Advantium Rx Alarm is dust and moisture resistant, it is NOT water-proof or completely sealed. It should be installed where it will not be subjected to rain or high concentrations of dust. Never pour or spray liquids directly onto the product.
- Install the Advantium Rx where the ambient temperature range is between 0° F and 140° F.
- THIS PRODUCT IS NOT INTENDED FOR USE IN EXPLOSIVE ENVIRONMENTS.
- DO NOT INSTALL THIS PRODUCT IN ANY HAZARDOUS ENVIRONMENT.
- If product appears damaged in any way, do not use and request service from CONCOA.

USER RESPONSIBILITY

Service to this product should only be performed by CONCOA or an authorized CONCOA agent. Requests for service may be made through CONCOA CUSTOMER SERVICE at 1-800-225-0473. Written requests may be made using CONCOA's FAX number at 1-757-422-3125 or CONCOA's E-MAIL at info@concoa.com

CONCOA accepts no responsibility for damage or injury if this product is modified in any way.

CONCOA assumes/accepts no liability or responsibility for damage to individuals or equipment that may occur when using this product.

Index

Power Requirements	1
Alarm Relay Specifications	1
Understanding Alarm Operation.....	2
Mounting Requirements.....	5
Installation Instructions.....	5
Connecting Alarm to Switchover.....	6
Connecting Alarm Outputs	7
Setting Remote Alarm Outputs.....	9
Muting Audible Alarm.....	11
Enabling Reserve Gas Function.....	11
Changing Input Signal Polarity.....	12
Warranty Information	13

UNDERSTANDING ALARM OPERATION

Figure 1

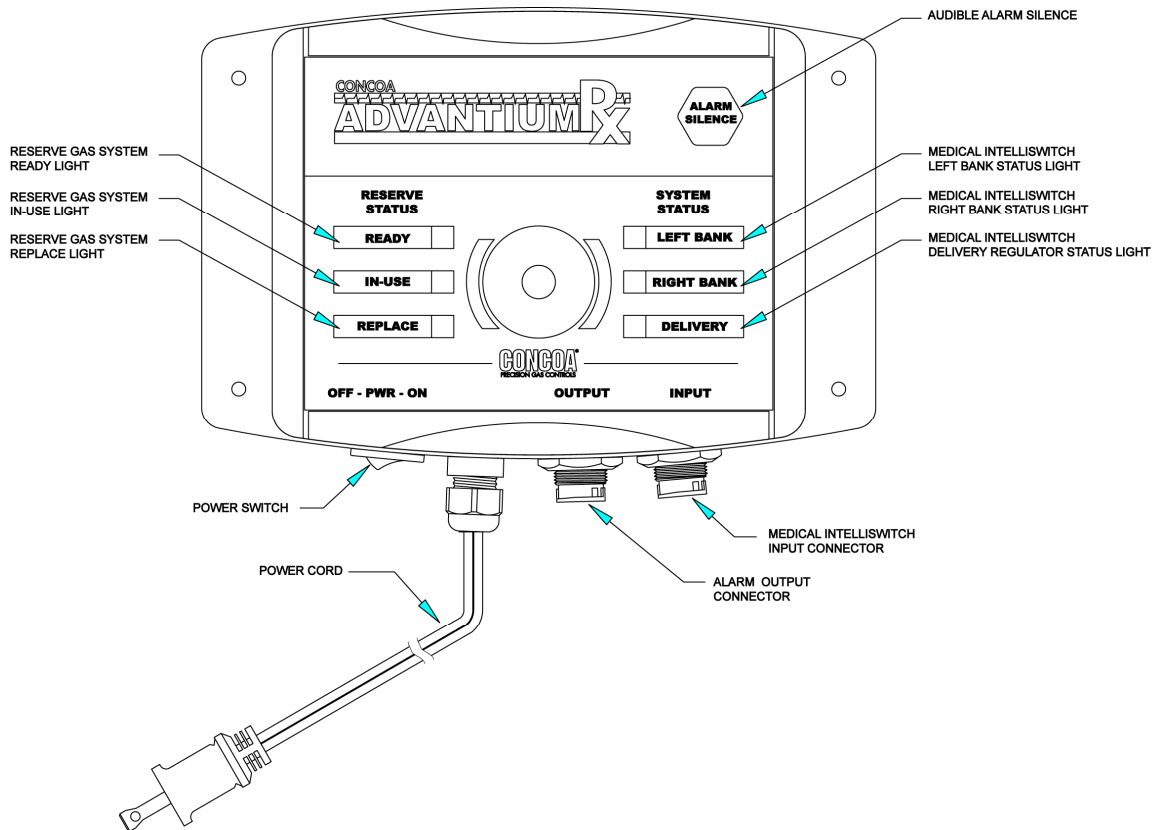

The Advantium Rx alarm is intended for use exclusively with the CONCOA Medical IntelliSwitch.

Figure 1 shows the location of the various inputs, outputs and indicators for the alarm. The Advantium Rx is available in two models. The 5740001 is factory set to operate on 120VAC 50-60hz, The 5740002 is factory set to operate on 220VAC 50-60hz. **MAKE SURE THAT YOU HAVE THE CORRECT MODEL FOR THE SUPPLY VOLTAGE YOU WILL BE CONNECTING TO.**

An ON/OFF power switch is provided on the bottom of the alarm. The switch must be in the ON position for the alarm to work.

Input signals coming from the Medical IntelliSwitch are connected to the alarm through an 8 position circular connector.

The Advantium Rx provides output signals to indicate the state of the various alarms it is monitoring. These signals are brought out through relay contacts to a 6 position circular connector. The Advantium Rx is factory set so that these output signals are brought out through Normally Closed (N.C.) contacts. Having these relays set to Normally Closed allows for configuring multiple Advantium Rx alarms for remote locations as needed.

These contacts can be changed, if needed, to Normally Open. Refer to the section in this manual “Changing Output Relay Contacts”.

Figure 1 shows a view of the front panel. It is laid out with three status lights on the right side representing the Left Inlet, Right Inlet, and Delivery Regulator alarm outputs originating from the Medical IntelliSwitch. On the left side of the front panel are three status lights that are used to indicate the condition of the Reserve Gas Supply (if this option is enabled). These signals also originate from the Medical IntelliSwitch. The three System Status indicator lights are bi-colored LEDs. This means that the same light can be turned ON as either a green indicator or a red indicator. A green LED indicates a normal condition while a red LED indicates an alarm condition.

In the center of the front panel is an audible transducer. This transducer is used to provide an audible indication of an alarm condition. In the upper right portion of the front panel is a button labeled “alarm silence”. This button allows the operator to silence the audible alarm even though an alarm condition still exists. This audible alarm can be disabled if desired. Refer to the Section “Muting Audible Alarm” for instruction on how this is done.

The Advantium Rx supplies a +12vdc signal brought out to the Input connector that serves as a common supply voltage for the relay contacts inside the Medical IntelliSwitch. The Advantium Rx uses the Normally Closed (N.C.) relay contact signals from the Medical IntelliSwitch to determine the state of the alarms monitored by the Medical IntelliSwitch. A schematic representation of what this looks like is shown in Figure 2.

Figure 2
Outputs from Medical IntelliSwitch

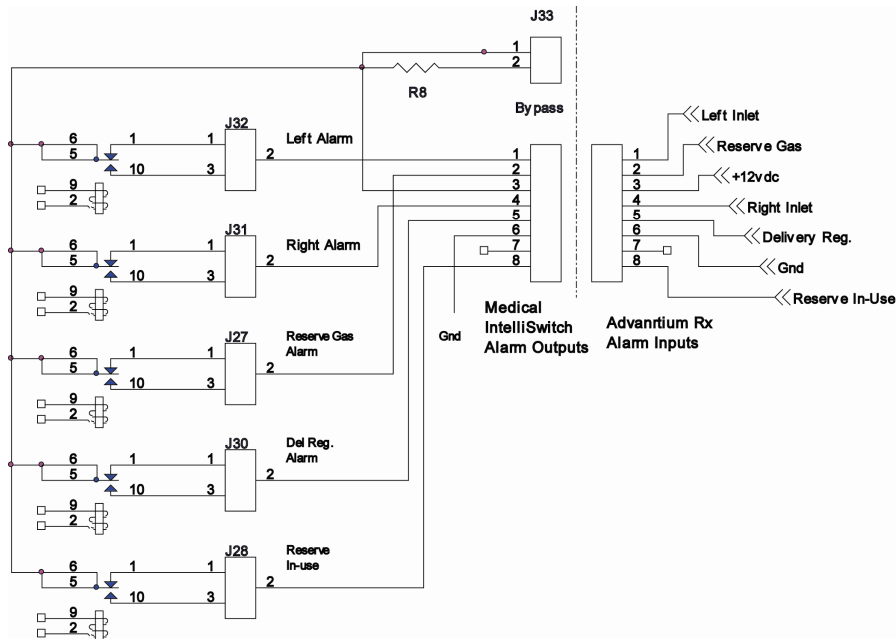

If there are no alarm conditions, the Advantium Rx will turn ON the green indicator next to the status being monitored.

The contacts inside the Medical IntelliSwitch representing a specific alarm condition such as “Left Inlet Alarm” open when that alarm condition occurs.

This is sensed by the Advantium Rx alarm. The response from the Advantium Rx is to change the color of the indicator next to the status from Green to Red. At the same time, if enabled, the audible buzzer in the Advantium Rx will begin to beep in a pulsing fashion. In addition, a set of contacts representing this alarm condition will open in the output section of the Advantium Rx alarm.

Not all Medical IntelliSwitch Systems are equipped with the Reserve Gas Option. In this case, the status lights used for monitoring the Reserve Gas are not needed. The Advantium Rx is factory set with the Reserve Gas Option disabled. Disabling this option keeps the indicator lights on the Reserve side of the alarm OFF. To enable the Reserve Gas option refer to the Section “Enabling the Reserve Gas Function” in this manual.

MOUNTING REQUIREMENTS

Figure 3

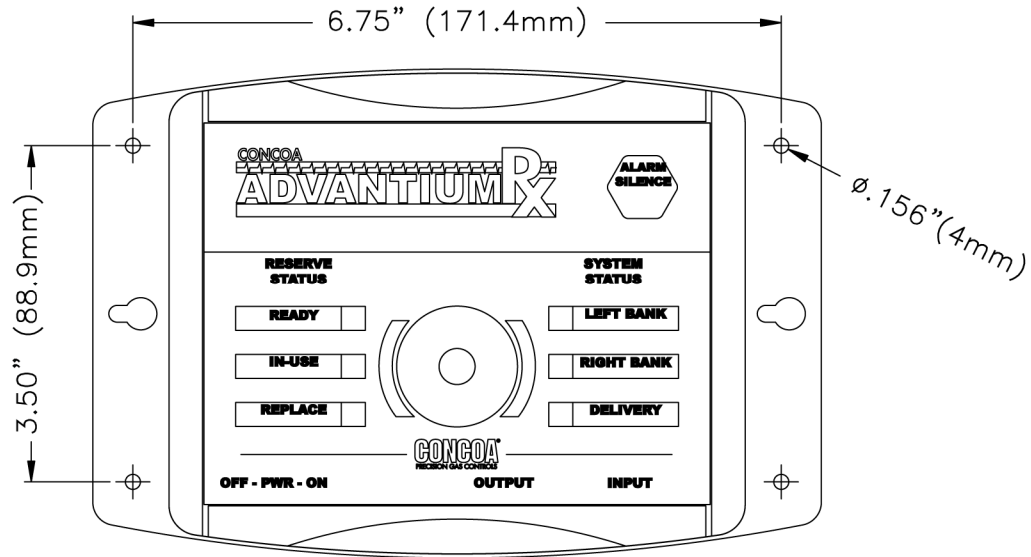

INSTALLATIONS INSTRUCTIONS

Included with the Advantium Rx Alarm are four (4) screws and wall anchors. If using the wall anchors drill a 1/8" hole in each of the four locations of the mounting holes of the alarm. The alarm enclosure or the template provided may be used. Place the wall anchors into the wall and attach the alarm using the screws provided.

Attach the input cable from the Medical IntelliSwitch to the Input of the alarm. If using the output of the alarm to connect to another alarm or system, attach the output cable at this time.

Plug the alarm into the appropriate power. Turn alarm ON by turning the Power switch on the bottom of the alarm to the ON position and test the system. The system may be tested once it is connected to the Medical IntelliSwitch by placing the Medical IntelliSwitch into "Test" mode and stepping through the tests that activate the alarm relay outputs. Refer to the operator's manual for the Medical IntelliSwitch to learn how to enter the "Test" mode.

CONNECTING ALARM TO SWITCHOVER

The Advantium Rx Remote Alarm is designed to interface to CONCOA's Medical IntelliSwitch™. The 8-pin remote alarm interface connector is located at the bottom of the Advantium Rx Alarm enclosure (See Figure 1). There are two ways to connect the product to the Medical IntelliSwitch. Ready made cable assemblies for connecting the Advantium Rx Alarm to the Medical IntelliSwitch™ are available from the factory. Contact your local CONCOA Distributor or call 1-800-225-0473 for information. The other option is to build your own cable assembly to connect the two devices. For convenience, a mating 8-pin connector is provided to use in building this cable assembly. The Medical IntelliSwitch also comes with a mating connector that is used to attach to the Medical IntelliSwitch side of the cable assembly. The recommended cable for this assembly is 24 AWG, 8-conductor stranded wire (Alpha # 1218C or equivalent). The length of this cable should be limited to 1500 feet.

Cut the 8-conductor cable to length. Remove the outer jacket of the cable to expose approximately 3/4 inch of the internal conductors on both sides of the cable. Strip away 1/4-inch of the insulation on each of the conductors.

On the 8-pin connector, slide the protective cover, cable retainer, and locking nut over the end of the cable as shown in Figure 4.

Figure 4

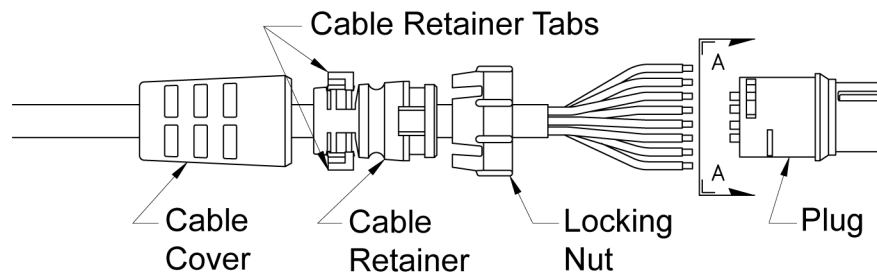
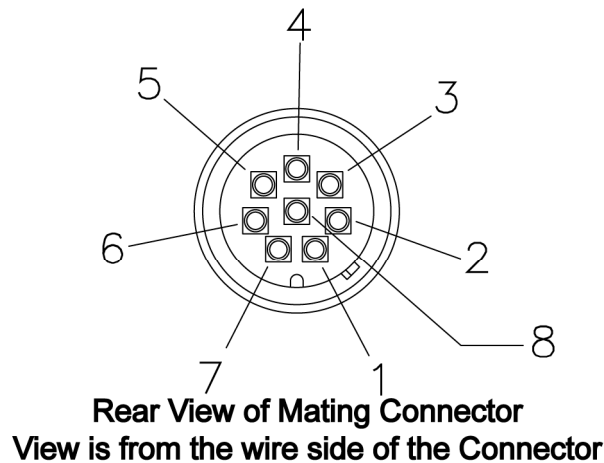

Figure 5



Using the pin assignments shown in Table 1 and the connector views in Figure 4 and Figure 5, solder the wires to the appropriate pins. After soldering is complete, slide the locking nut over the connector body. Snap the cable retainer into the body and then slide the protective cover over the cable retainer.

Table 1— Remote Alarm Pin Assignments

Medical IntelliSwitch™ Pin Number	5740001/5740002 Alarm Pin Number	Function
1	1	Left Inlet Alarm
2	2	Delivery Regulator Alarm.
3	3	+12v (provided by the remote alarm)
4	4	Right Inlet Alarm
5	5	Reserve Gas Supply Alarm.
6	6	Ground (provided by the remote alarm)
7	7	N.C.
8	8	Reserve In-Use

CONNECTING ALARM OUTPUTS

The Advantium Rx provides output signals corresponding to the alarm conditions that it senses. These signals are presented through relay contacts and are brought out to a 6 pin circular connector on the bottom of the alarm. A mating 6 pin connector is provided to allow for connecting the alarm to other equipment. Pre-made cables are also available. Contact your local CONCOA Distributor or call 1-800-225-0473 for information. The relay contacts are configurable. They are factory set as Normally Closed (N.C.) but may be changed to Normally Open (N.O.) if needed. Refer to the Section “Setting Remote Alarm Outputs” in the manual for the procedure.

The recommended cable for making an output cable assembly is 24 AWG, 6-conductor stranded wire (Alpha # 1216C or equivalent). The length of this cable should be limited to 1500 feet.

Cut the 6-conductor cable to length. Remove the outer jacket of the cable to expose approximately 3/4 inch of the internal conductors on both sides of the cable. Strip away 1/4-inch of the insulation on each of the conductors.

On the 6-pin connector, slide the protective cover, cable retainer, and locking nut over the end of the cable as shown in Figure 6.

Using the pin assignments shown in Table 2 and the connector views in Figure 6 and Figure 7, solder the wires to the appropriate pins. After soldering is complete, slide the locking nut over the connector body. Snap the cable retainer into the body and then slide the protective cover over the cable retainer.

CONNECTING ALARM OUTPUTS (cont.)

Figure 6

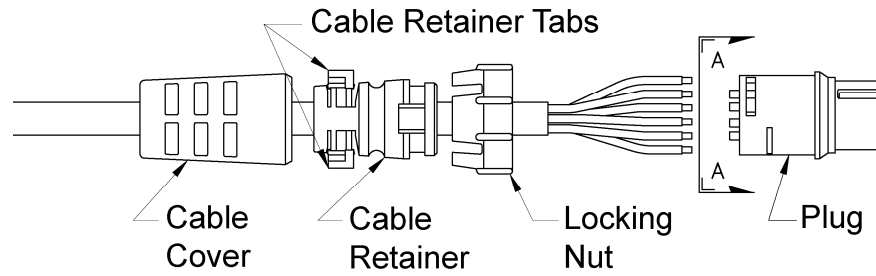

Figure 7

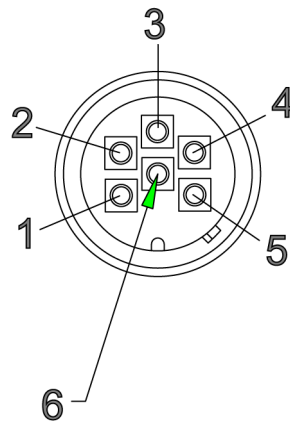

Table 2— Remote Alarm Output Pin Assignments

Alarm Output Connector Pin Number	Function
1	Left Inlet Alarm
2	Delivery Regulator Alarm.
3	+12v (provided by the remote alarm)
4	Right Inlet Alarm
5	Reserve Gas Supply Alarm.
6	Reserve Gas In-Use

SETTING REMOTE ALARM OUTPUTS

The output signals from the Advantium Rx are brought out of the alarm through relay contacts. These contacts are set as Normally Closed (N.C.) FACTORY DEFAULT. The relay contacts can be reconfigured as Normally Open (N.O.) . To change the relay configuration perform the following steps:

1. Turn AC power switch OFF and unplug the alarm from AC power.
2. If the alarm is anchored to a wall remove the four screws holding it to the wall to gain access to the back of the unit.
3. Separate the front and back of the unit by loosening the 4 screws located on the rear of the enclosure.
4. Figure 8 shows the location of the jumpers on the circuit board for setting the contacts.
5. Using Table 3 and Figure 8 set the jumpers to the desired contact arrangement.
6. Reattach the two sections of the enclosure with the screws previously removed.
7. Re-attach/attach the alarm to the wall with the 4 screws and the wall anchors provided
8. Make the necessary connections to the alarm and plug the alarm cable into the alarm connector on the bottom of the cabinet.
9. Plug the alarm back into the AC power. Turn AC power switch ON.

Table 3

Jumper	Function
J2	Left Inlet Alarm
J4	Right Inlet Alarm
J5	Delivery Regulator Alarm
J6	Reserve Gas Source Alarm
J7	Reserve Gas In-Use

Figure 8

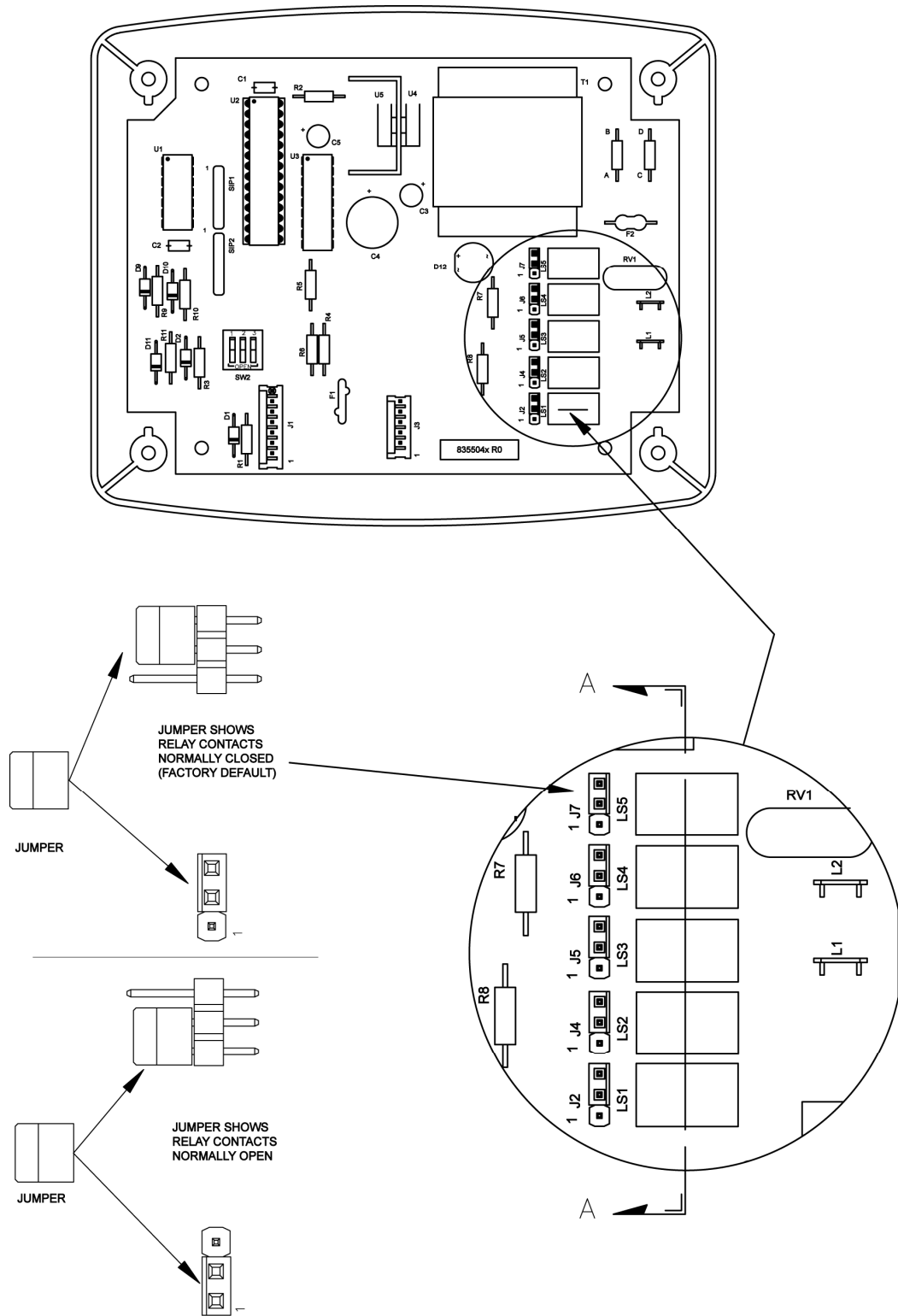

MUTING AUDIBLE ALARM

It is sometimes desirable to silence the audible alarm on the Advantium Rx. This can be accomplished by turning OFF the audible alarm switch inside the alarm. **FACTORY DEFAULT IS ON.** To turn OFF the audible alarm perform the following steps:

1. Turn AC power switch OFF and unplug the alarm from AC power.
2. If the alarm is anchored to a wall remove the four screws holding it to the wall to gain access to the back of the unit.
3. Separate the front and back of the unit by loosening the 4 screws located on the rear of the enclosure.
4. Using Figure 9 locate SW2 switch 3 and turn it OFF.
5. Replace back cover using the previously removed screws.
6. Re-attach the alarm to the wall using the previously removed screws.
7. Plug the alarm back into AC power.
8. Turn alarm ON by turn the power switch on the bottom of the alarm to the ON position.
9. Test unit.

ENABLING RESERVE GAS FUNCTION

The Advantium Rx alarm is shipped from the factory with the Reserve Gas Monitoring feature shut OFF. If you have purchased a Medical IntelliSwitch with the Reserve Gas Option you will need to enable the monitoring feature inside the alarm. **FACTORY FAULT IS OFF.** To enable the feature perform the following steps:

1. Turn AC power switch OFF and unplug the alarm from AC power.
2. If the alarm is anchored to a wall remove the four screws holding it to the wall to gain access to the back of the unit.
3. Separate the front and back of the unit by loosening the 4 screws located on the rear of the enclosure.
4. Using Figure 9 locate SW2 switch 1 and turn it ON.
5. Replace back cover using the previously removed screws.
6. Re-attach the alarm to the wall using the previously removed screws.
7. Plug the alarm back into AC power.
8. Turn alarm ON by turn the power switch on the bottom of the alarm to the ON position.
9. Test unit.

CHANGING INPUT SIGNAL POLARITY

The Medical IntelliSwitch provides a normally 'ON' signal to the alarm inputs when the switchover is operating properly. If an alarm condition occurs, this signal turns from 'ON' to 'OFF'. It is possible to change how the alarm interprets the inputs if for some reason the outputs of the Medical IntelliSwitch are configured as Normally Open (N.O.). Under normal circumstances there should be no reason to change the input polarity. **NOTE: CHANGING THIS INPUT SIGNAL POLARITY WILL CAUSE THE ALARM TO FUNCTION IMPROPERLY IF IT IS USED WITH THE MEDICAL INTELLISWITCH. FACTORY DEFAULT IS NORMALLY CLOSED (N.C.)** .To change the inputs so that an input is 'OFF' when there is no alarm and 'ON' when an alarm occurs perform the following steps:

1. Turn AC power switch OFF and unplug the alarm from AC power.
2. If the alarm is anchored to a wall remove the four screws holding it to the wall to gain access to the back of the unit.
3. Separate the front and back of the unit by loosening the 4 screws located on the rear of the enclosure.
4. Using Figure 9 locate SW2 switch 2 and turn it ON.
5. Replace back cover using the previously removed screws.
6. Re-attach the alarm to the wall using the previously removed screws.
7. Plug the alarm back into AC power.
8. Turn alarm ON by turn the power switch on the bottom of the alarm to the ON position.
9. Test unit.

Figure 9

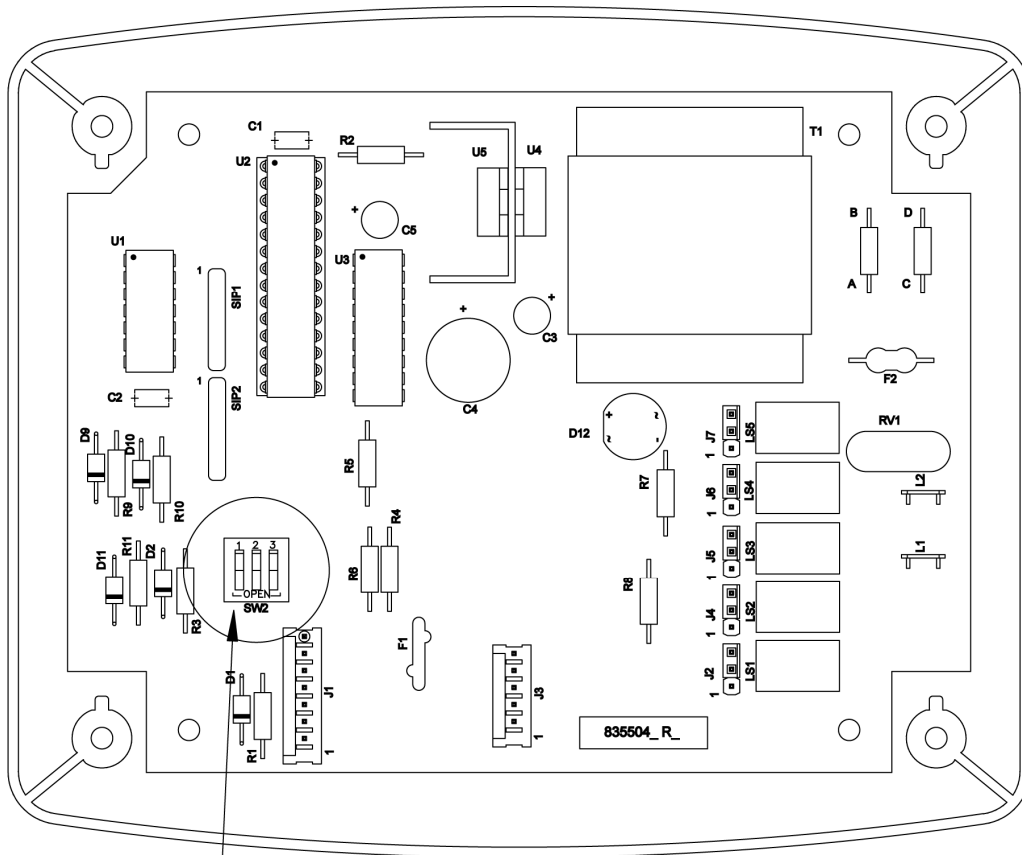

ON - rocker down in direction of arrow

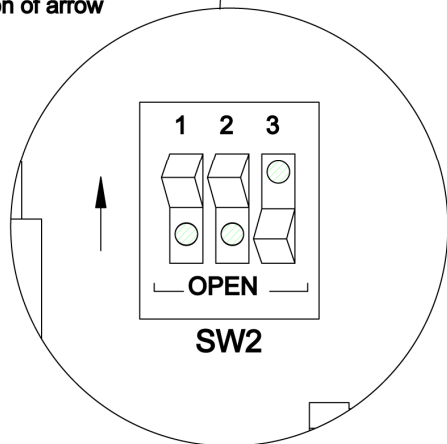

Table 4

SWITCH	FUNCTION
1	Reserve Gas Enable
2	Input Signal Polarity
3	Audible Alarm Mute

ACCESSORIES

Pre-assembled cables for connecting a Medical IntelliSwitch to the Advantium Rx Alarm and the Reserve Gas Supply Option to the Medical IntelliSwitch are available from your CONCOA distributor. Refer to the table below for cable assembly descriptions and part numbers.

Cable Description	Part Number
Advantium Rx Input Cable	5295325-xx*
Advantium Rx Output Cable	5295328-xx*
Reserve Gas to Medical IntelliSwitch Cable, 25 ft.	5295326
Reserve Gas to Medical IntelliSwitch Cable, 25 ft.	5295327-xx*
Advantium Rx Interconnect Cable	5295330-xx*

* - Replace '-xx' with cable length. Length is in feet. Choices are -03 (3ft.), --10 (10ft.), -25 (25ft.), -50 (50 ft.), -100 (100ft.)

Example: Order 10 ft. Advantium RX Input Cable

PN 5295325-10

WARRANTY INFORMATION

This equipment is sold by CONTROLS CORPORATION OF AMERICA under the warranties set forth in the following paragraphs. Such warranties are extended only with respect to the purchase of this equipment directly from CONTROLS CORPORATION OF AMERICA or its Authorized Distributors as new merchandise and are extended to the first Buyer thereof other than for the purpose of resale.

For a period of one (1) year from the date of original delivery (90 days in corrosive service) to Buyer or to Buyer's order, this equipment is warranted to be free from functional defects in materials and workmanship and to conform to the description of this equipment contained in this manual and any accompanying labels and/or inserts, provided that the same is properly operated under conditions of normal use and that regular periodic maintenance and service is performed or replacements made in accordance with the instructions provided. The foregoing warranties shall not apply if the equipment has been repaired: other than by CONTROLS CORPORATION OF AMERICA or a designated service facility or in accordance with written instructions provided by CONTROLS CORPORATION OF AMERICA, or altered by anyone other than CONTROLS CORPORATION OF AMERICA, or if the equipment has been subject to abuse, misuse, negligence or accident.

CONTROLS CORPORATION OF AMERICA's sole and exclusive obligation and Buyer's sole and exclusive remedy under the above warranties is limited to repairing or replacing, free of charge, at CONTROLS CORPORATION OF AMERICA's option, the equipment or part, which is reported to its Authorized Distributor from whom purchased, and which if so advised, is returned with a statement of the observed deficiency, and proof of purchase of equipment or part not later than seven (7) days after the expiration date of the applicable warranty, to the nearest designated service facility during normal business hours, transportation charges prepaid, and which upon examination, is found not to comply with the above warranties. Return trip transportation charges for the equipment or part shall be paid by Buyer.

CONTROLS CORPORATION OF AMERICA SHALL NOT BE OTHERWISE LIABLE FOR ANY DAMAGES INCLUDING BUT NOT LIMITED TO: INCIDENTAL DAMAGES, CONSEQUENTIAL DAMAGES, OR SPECIAL DAMAGES, WHETHER SUCH DAMAGES RESULT FROM NEGLIGENCE, BREACH OF WARRANTY OR OTHERWISE.

THERE ARE NO EXPRESS OR IMPLIED WARRANTIES WHICH EXTEND BEYOND THE WARRANTIES HEREINABOVE SET FORTH. CONTROLS CORPORATION OF AMERICA MAKES NO WARRANTY OF MERCHANTABILITY OR FITNESS FOR A PARTICULAR PURPOSE WITH RESPECT TO THE EQUIPMENT OR PARTS THEREOF.



ADI 9508-B

Certified ISO 9001:2000

Controls Corporation of America

1501 Harpers Road Virginia Beach, VA 23454

Telephone 1-800-225-0473 or 757-422-8330 • Fax 757-422-3125

www.concoa.com



Advantium Rx Alarm

INSTALLATION AND OPERATING INSTRUCTIONS

Carefully Read These Instructions Before Operating

Controls Corporation of America
1501 Harpers Road • Virginia Beach, VA 23454
Telephone 1-800-225-0473 or 757-422-8330 • Fax 757-422-3125
www.concoa.com

November 2009
Revision B

SAFETY



BASIC SAFETY PRECAUTIONS MUST BE FOLLOWED TO REDUCE THE RISK OF FIRE, ELECTRICAL SHOCK OR INJURY.

- Connect the Advantium Rx to the correct line voltage. A label on the product identifies what voltage it is wired for. CONNECTION TO AN INCORRECT VOLTAGE CAN CAUSE SERIOUS DAMAGE TO THE PRODUCT AND WILL VOID ANY WARRANTY.
- While the Advantium Rx Alarm is dust and moisture resistant, it is NOT water-proof or completely sealed. It should be installed where it will not be subjected to rain or high concentrations of dust. Never pour or spray liquids directly onto the product.
- Install the Advantium Rx where the ambient temperature range is between 0° F and 140° F.
- THIS PRODUCT IS NOT INTENDED FOR USE IN EXPLOSIVE ENVIRONMENTS.
- DO NOT INSTALL THIS PRODUCT IN ANY HAZARDOUS ENVIRONMENT.
- If product appears damaged in any way, do not use and request service from CONCOA.

USER RESPONSIBILITY

Service to this product should only be performed by CONCOA or an authorized CONCOA agent. Requests for service may be made through CONCOA CUSTOMER SERVICE at 1-800-225-0473. Written requests may be made using CONCOA's FAX number at 1-757-422-3125 or CONCOA's E-MAIL at info@concoa.com

CONCOA accepts no responsibility for damage or injury if this product is modified in any way.

CONCOA assumes/accepts no liability or responsibility for damage to individuals or equipment that may occur when using this product.

Index

Power Requirements	1
Alarm Relay Specifications	1
Understanding Alarm Operation.....	2
Mounting Requirements.....	5
Installation Instructions.....	5
Connecting Alarm to Switchover.....	6
Connecting Alarm Outputs	7
Setting Remote Alarm Outputs.....	9
Muting Audible Alarm.....	11
Enabling Reserve Gas Function.....	11
Changing Input Signal Polarity.....	12
Warranty Information	13

UNDERSTANDING ALARM OPERATION

Figure 1

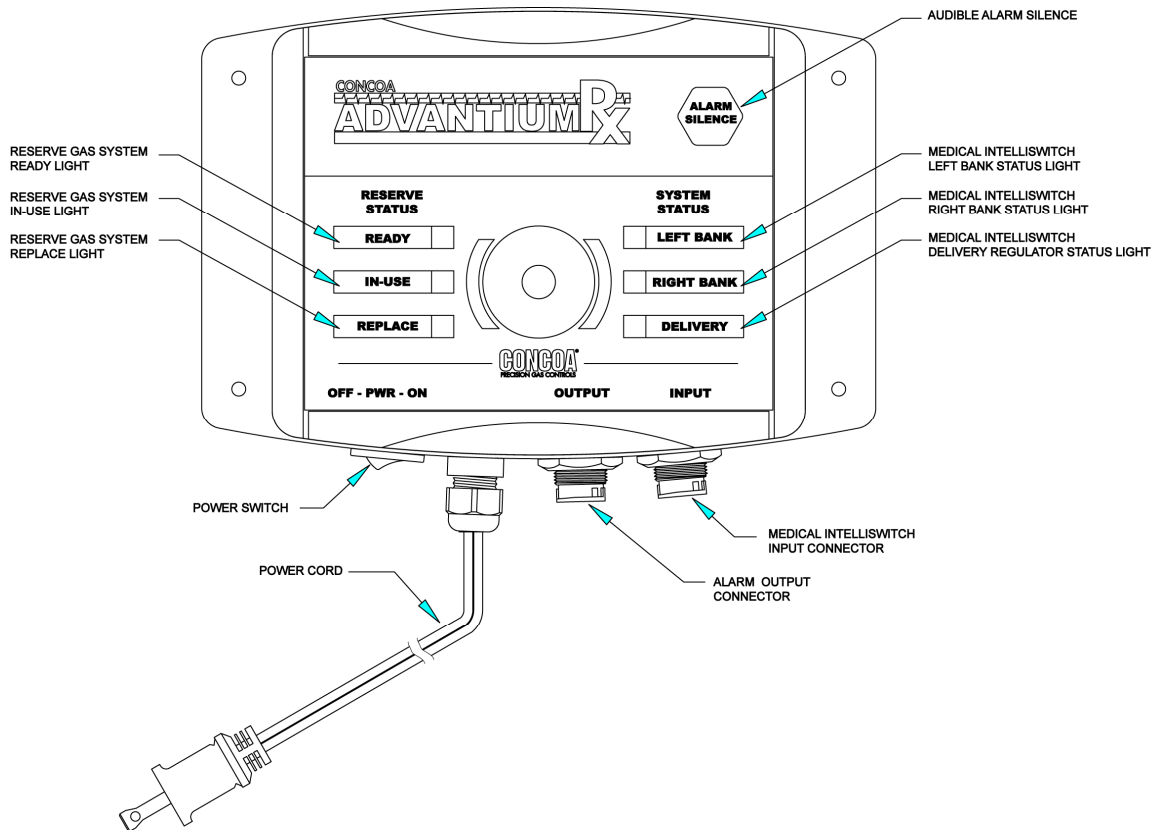

The Advantium Rx alarm is intended for use exclusively with the CONCOA Medical IntelliSwitch.

Figure 1 shows the location of the various inputs, outputs and indicators for the alarm. The Advantium Rx is available in two models. The 5740001 is factory set to operate on 120VAC 50-60hz, The 5740002 is factory set to operate on 220VAC 50-60hz. **MAKE SURE THAT YOU HAVE THE CORRECT MODEL FOR THE SUPPLY VOLTAGE YOU WILL BE CONNECTING TO.**

An ON/OFF power switch is provided on the bottom of the alarm. The switch must be in the ON position for the alarm to work.

Input signals coming from the Medical IntelliSwitch are connected to the alarm through an 8 position circular connector.

The Advantium Rx provides output signals to indicate the state of the various alarms it is monitoring. These signals are brought out through relay contacts to a 6 position circular connector. The Advantium Rx is factory set so that these output signals are brought out through Normally Closed (N.C.) contacts. Having these relays set to Normally Closed allows for configuring multiple Advantium Rx alarms for remote locations as needed.

These contacts can be changed, if needed, to Normally Open. Refer to the section in this manual “Changing Output Relay Contacts”.

Figure 1 shows a view of the front panel. It is laid out with three status lights on the right side representing the Left Inlet, Right Inlet, and Delivery Regulator alarm outputs originating from the Medical IntelliSwitch. On the left side of the front panel are three status lights that are used to indicate the condition of the Reserve Gas Supply (if this option is enabled). These signals also originate from the Medical IntelliSwitch. The three System Status indicator lights are bi-colored LEDs. This means that the same light can be turned ON as either a green indicator or a red indicator. A green LED indicates a normal condition while a red LED indicates an alarm condition.

In the center of the front panel is an audible transducer. This transducer is used to provide an audible indication of an alarm condition. In the upper right portion of the front panel is a button labeled “alarm silence”. This button allows the operator to silence the audible alarm even though an alarm condition still exists. This audible alarm can be disabled if desired. Refer to the Section “Muting Audible Alarm” for instruction on how this is done.

The Advantium Rx supplies a +12vdc signal brought out to the Input connector that serves as a common supply voltage for the relay contacts inside the Medical IntelliSwitch. The Advantium Rx uses the Normally Closed (N.C.) relay contact signals from the Medical IntelliSwitch to determine the state of the alarms monitored by the Medical IntelliSwitch. A schematic representation of what this looks like is shown in Figure 2.

Figure 2
Outputs from Medical IntelliSwitch

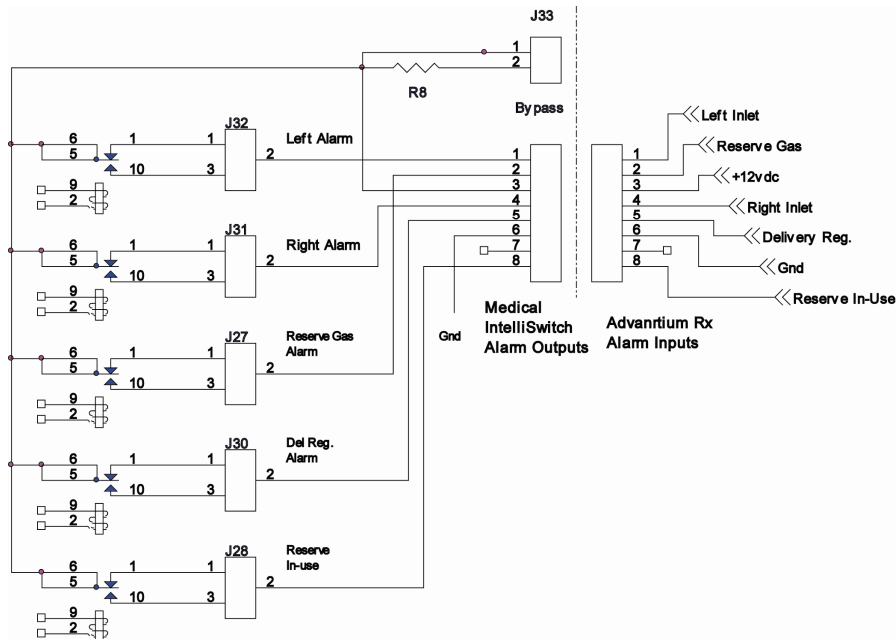

If there are no alarm conditions, the Advantium Rx will turn ON the green indicator next to the status being monitored.

The contacts inside the Medical IntelliSwitch representing a specific alarm condition such as “Left Inlet Alarm” open when that alarm condition occurs.

This is sensed by the Advantium Rx alarm. The response from the Advantium Rx is to change the color of the indicator next to the status from Green to Red. At the same time, if enabled, the audible buzzer in the Advantium Rx will begin to beep in a pulsing fashion. In addition, a set of contacts representing this alarm condition will open in the output section of the Advantium Rx alarm.

Not all Medical IntelliSwitch Systems are equipped with the Reserve Gas Option. In this case, the status lights used for monitoring the Reserve Gas are not needed. The Advantium Rx is factory set with the Reserve Gas Option disabled. Disabling this option keeps the indicator lights on the Reserve side of the alarm OFF. To enable the Reserve Gas option refer to the Section “Enabling the Reserve Gas Function” in this manual.

MOUNTING REQUIREMENTS

Figure 3

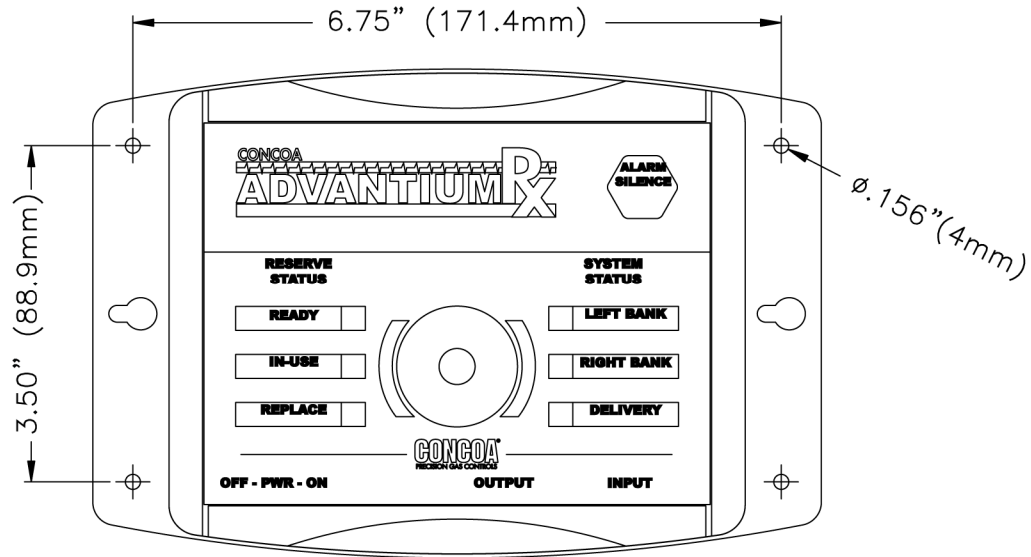

INSTALLATIONS INSTRUCTIONS

Included with the Advantium Rx Alarm are four (4) screws and wall anchors. If using the wall anchors drill a 1/8" hole in each of the four locations of the mounting holes of the alarm. The alarm enclosure or the template provided may be used. Place the wall anchors into the wall and attach the alarm using the screws provided.

Attach the input cable from the Medical IntelliSwitch to the Input of the alarm. If using the output of the alarm to connect to another alarm or system, attach the output cable at this time.

Plug the alarm into the appropriate power. Turn alarm ON by turning the Power switch on the bottom of the alarm to the ON position and test the system. The system may be tested once it is connected to the Medical IntelliSwitch by placing the Medical IntelliSwitch into "Test" mode and stepping through the tests that activate the alarm relay outputs. Refer to the operator's manual for the Medical IntelliSwitch to learn how to enter the "Test" mode.

CONNECTING ALARM TO SWITCHOVER

The Advantium Rx Remote Alarm is designed to interface to CONCOA's Medical IntelliSwitch™. The 8-pin remote alarm interface connector is located at the bottom of the Advantium Rx Alarm enclosure (See Figure 1). There are two ways to connect the product to the Medical IntelliSwitch. Ready made cable assemblies for connecting the Advantium Rx Alarm to the Medical IntelliSwitch™ are available from the factory. Contact your local CONCOA Distributor or call 1-800-225-0473 for information. The other option is to build your own cable assembly to connect the two devices. For convenience, a mating 8-pin connector is provided to use in building this cable assembly. The Medical IntelliSwitch also comes with a mating connector that is used to attach to the Medical IntelliSwitch side of the cable assembly. The recommended cable for this assembly is 24 AWG, 8-conductor stranded wire (Alpha # 1218C or equivalent). The length of this cable should be limited to 1500 feet.

Cut the 8-conductor cable to length. Remove the outer jacket of the cable to expose approximately 3/4 inch of the internal conductors on both sides of the cable. Strip away 1/4-inch of the insulation on each of the conductors.

On the 8-pin connector, slide the protective cover, cable retainer, and locking nut over the end of the cable as shown in Figure 4.

Figure 4

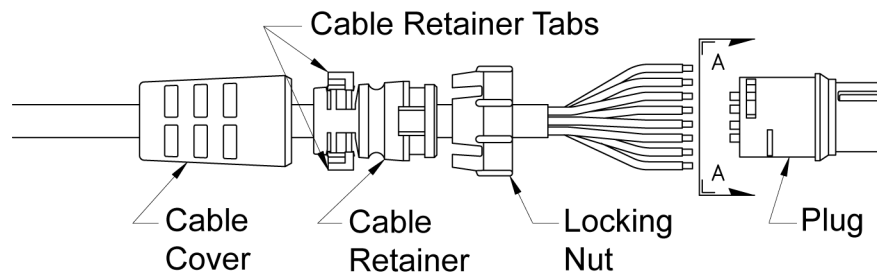
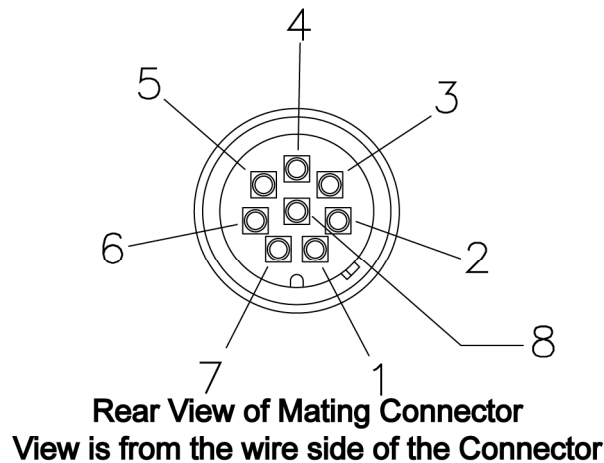

Figure 5



Using the pin assignments shown in Table 1 and the connector views in Figure 4 and Figure 5, solder the wires to the appropriate pins. After soldering is complete, slide the locking nut over the connector body. Snap the cable retainer into the body and then slide the protective cover over the cable retainer.

Table 1— Remote Alarm Pin Assignments

Medical IntelliSwitch™ Pin Number	5740001/5740002 Alarm Pin Number	Function
1	1	Left Inlet Alarm
2	2	Delivery Regulator Alarm.
3	3	+12v (provided by the remote alarm)
4	4	Right Inlet Alarm
5	5	Reserve Gas Supply Alarm.
6	6	Ground (provided by the remote alarm)
7	7	N.C.
8	8	Reserve In-Use

CONNECTING ALARM OUTPUTS

The Advantium Rx provides output signals corresponding to the alarm conditions that it senses. These signals are presented through relay contacts and are brought out to a 6 pin circular connector on the bottom of the alarm. A mating 6 pin connector is provided to allow for connecting the alarm to other equipment. Pre-made cables are also available. Contact your local CONCOA Distributor or call 1-800-225-0473 for information. The relay contacts are configurable. They are factory set as Normally Closed (N.C.) but may be changed to Normally Open (N.O.) if needed. Refer to the Section “Setting Remote Alarm Outputs” in the manual for the procedure.

The recommended cable for making an output cable assembly is 24 AWG, 6-conductor stranded wire (Alpha # 1216C or equivalent). The length of this cable should be limited to 1500 feet.

Cut the 6-conductor cable to length. Remove the outer jacket of the cable to expose approximately 3/4 inch of the internal conductors on both sides of the cable. Strip away 1/4-inch of the insulation on each of the conductors.

On the 6-pin connector, slide the protective cover, cable retainer, and locking nut over the end of the cable as shown in Figure 6.

Using the pin assignments shown in Table 2 and the connector views in Figure 6 and Figure 7, solder the wires to the appropriate pins. After soldering is complete, slide the locking nut over the connector body. Snap the cable retainer into the body and then slide the protective cover over the cable retainer.

CONNECTING ALARM OUTPUTS (cont.)

Figure 6

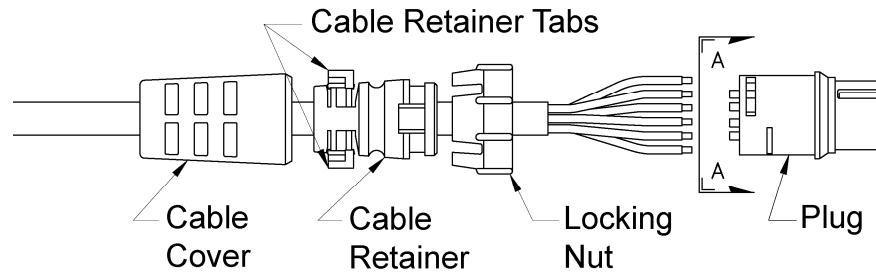

Figure 7

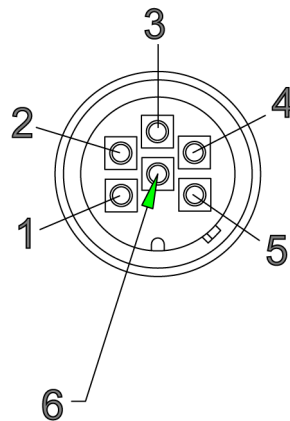

Table 2— Remote Alarm Output Pin Assignments

Alarm Output Connector Pin Number	Function
1	Left Inlet Alarm
2	Delivery Regulator Alarm.
3	+12v (provided by the remote alarm)
4	Right Inlet Alarm
5	Reserve Gas Supply Alarm.
6	Reserve Gas In-Use

SETTING REMOTE ALARM OUTPUTS

The output signals from the Advantium Rx are brought out of the alarm through relay contacts. These contacts are set as Normally Closed (N.C.) FACTORY DEFAULT. The relay contacts can be reconfigured as Normally Open (N.O.) . To change the relay configuration perform the following steps:

1. Turn AC power switch OFF and unplug the alarm from AC power.
2. If the alarm is anchored to a wall remove the four screws holding it to the wall to gain access to the back of the unit.
3. Separate the front and back of the unit by loosening the 4 screws located on the rear of the enclosure.
4. Figure 8 shows the location of the jumpers on the circuit board for setting the contacts.
5. Using Table 3 and Figure 8 set the jumpers to the desired contact arrangement.
6. Reattach the two sections of the enclosure with the screws previously removed.
7. Re-attach/attach the alarm to the wall with the 4 screws and the wall anchors provided
8. Make the necessary connections to the alarm and plug the alarm cable into the alarm connector on the bottom of the cabinet.
9. Plug the alarm back into the AC power. Turn AC power switch ON.

Table 3

Jumper	Function
J2	Left Inlet Alarm
J4	Right Inlet Alarm
J5	Delivery Regulator Alarm
J6	Reserve Gas Source Alarm
J7	Reserve Gas In-Use

Figure 8

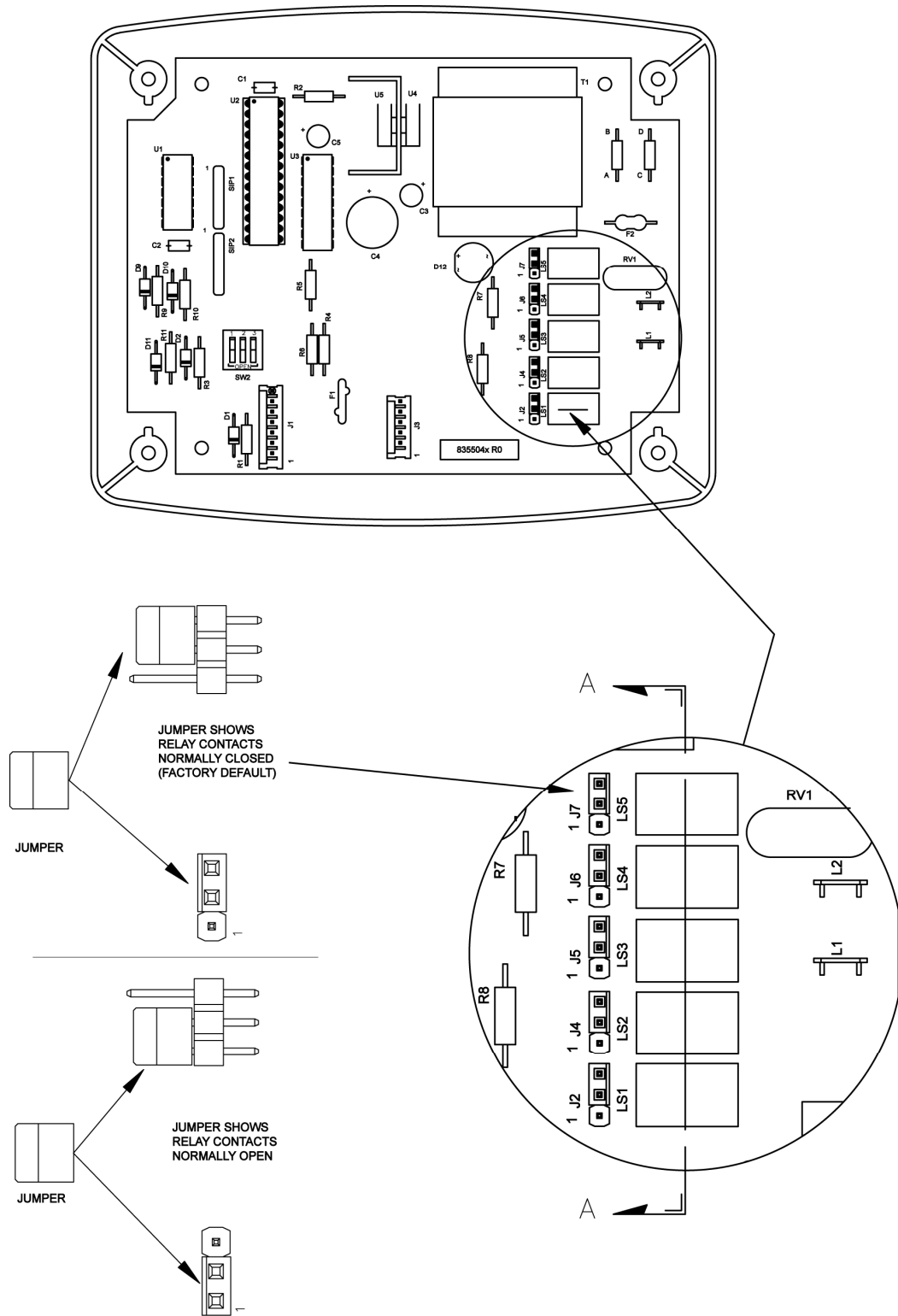

MUTING AUDIBLE ALARM

It is sometimes desirable to silence the audible alarm on the Advantium Rx. This can be accomplished by turning OFF the audible alarm switch inside the alarm. **FACTORY DEFAULT IS ON.** To turn OFF the audible alarm perform the following steps:

1. Turn AC power switch OFF and unplug the alarm from AC power.
2. If the alarm is anchored to a wall remove the four screws holding it to the wall to gain access to the back of the unit.
3. Separate the front and back of the unit by loosening the 4 screws located on the rear of the enclosure.
4. Using Figure 9 locate SW2 switch 3 and turn it OFF.
5. Replace back cover using the previously removed screws.
6. Re-attach the alarm to the wall using the previously removed screws.
7. Plug the alarm back into AC power.
8. Turn alarm ON by turn the power switch on the bottom of the alarm to the ON position.
9. Test unit.

ENABLING RESERVE GAS FUNCTION

The Advantium Rx alarm is shipped from the factory with the Reserve Gas Monitoring feature shut OFF. If you have purchased a Medical IntelliSwitch with the Reserve Gas Option you will need to enable the monitoring feature inside the alarm. **FACTORY FAULT IS OFF.** To enable the feature perform the following steps:

1. Turn AC power switch OFF and unplug the alarm from AC power.
2. If the alarm is anchored to a wall remove the four screws holding it to the wall to gain access to the back of the unit.
3. Separate the front and back of the unit by loosening the 4 screws located on the rear of the enclosure.
4. Using Figure 9 locate SW2 switch 1 and turn it ON.
5. Replace back cover using the previously removed screws.
6. Re-attach the alarm to the wall using the previously removed screws.
7. Plug the alarm back into AC power.
8. Turn alarm ON by turn the power switch on the bottom of the alarm to the ON position.
9. Test unit.

CHANGING INPUT SIGNAL POLARITY

The Medical IntelliSwitch provides a normally 'ON' signal to the alarm inputs when the switchover is operating properly. If an alarm condition occurs, this signal turns from 'ON' to 'OFF'. It is possible to change how the alarm interprets the inputs if for some reason the outputs of the Medical IntelliSwitch are configured as Normally Open (N.O.). Under normal circumstances there should be no reason to change the input polarity. **NOTE: CHANGING THIS INPUT SIGNAL POLARITY WILL CAUSE THE ALARM TO FUNCTION IMPROPERLY IF IT IS USED WITH THE MEDICAL INTELLISWITCH. FACTORY DEFAULT IS NORMALLY CLOSED (N.C.)** .To change the inputs so that an input is 'OFF' when there is no alarm and 'ON' when an alarm occurs perform the following steps:

1. Turn AC power switch OFF and unplug the alarm from AC power.
2. If the alarm is anchored to a wall remove the four screws holding it to the wall to gain access to the back of the unit.
3. Separate the front and back of the unit by loosening the 4 screws located on the rear of the enclosure.
4. Using Figure 9 locate SW2 switch 2 and turn it ON.
5. Replace back cover using the previously removed screws.
6. Re-attach the alarm to the wall using the previously removed screws.
7. Plug the alarm back into AC power.
8. Turn alarm ON by turn the power switch on the bottom of the alarm to the ON position.
9. Test unit.

Figure 9

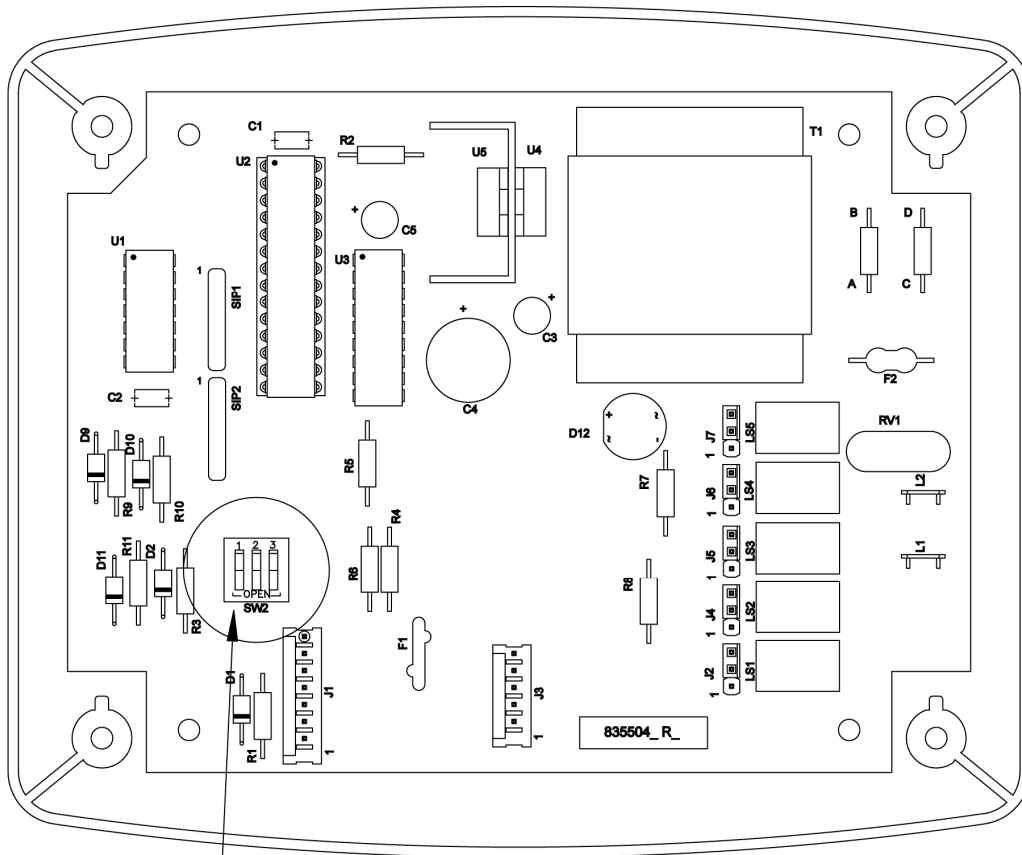

ON - rocker down in direction of arrow

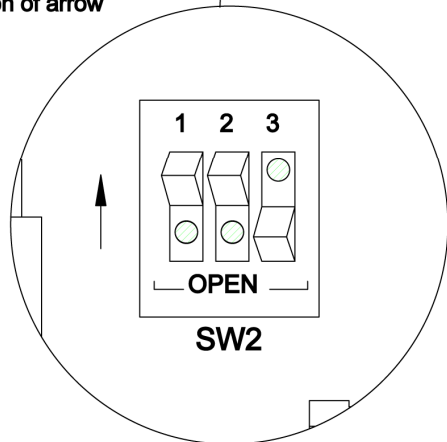

Table 4

SWITCH	FUNCTION
1	Reserve Gas Enable
2	Input Signal Polarity
3	Audible Alarm Mute

ACCESSORIES

Pre-assembled cables for connecting a Medical IntelliSwitch to the Advantium Rx Alarm and the Reserve Gas Supply Option to the Medical IntelliSwitch are available from your CONCOA distributor. Refer to the table below for cable assembly descriptions and part numbers.

Cable Description	Part Number
Advantium Rx Input Cable	5295325-xx*
Advantium Rx Output Cable	5295328-xx*
Reserve Gas to Medical IntelliSwitch Cable, 25 ft.	5295326
Reserve Gas to Medical IntelliSwitch Cable, 25 ft.	5295327-xx*
Advantium Rx Interconnect Cable	5295330-xx*

* - Replace '-xx' with cable length. Length is in feet. Choices are -03 (3ft.), --10 (10ft.), -25 (25ft.), -50 (50 ft.), -100 (100ft.)

Example: Order 10 ft. Advantium RX Input Cable

PN 5295325-10

WARRANTY INFORMATION

This equipment is sold by CONTROLS CORPORATION OF AMERICA under the warranties set forth in the following paragraphs. Such warranties are extended only with respect to the purchase of this equipment directly from CONTROLS CORPORATION OF AMERICA or its Authorized Distributors as new merchandise and are extended to the first Buyer thereof other than for the purpose of resale.

For a period of one (1) year from the date of original delivery (90 days in corrosive service) to Buyer or to Buyer's order, this equipment is warranted to be free from functional defects in materials and workmanship and to conform to the description of this equipment contained in this manual and any accompanying labels and/or inserts, provided that the same is properly operated under conditions of normal use and that regular periodic maintenance and service is performed or replacements made in accordance with the instructions provided. The foregoing warranties shall not apply if the equipment has been repaired: other than by CONTROLS CORPORATION OF AMERICA or a designated service facility or in accordance with written instructions provided by CONTROLS CORPORATION OF AMERICA, or altered by anyone other than CONTROLS CORPORATION OF AMERICA, or if the equipment has been subject to abuse, misuse, negligence or accident.

CONTROLS CORPORATION OF AMERICA's sole and exclusive obligation and Buyer's sole and exclusive remedy under the above warranties is limited to repairing or replacing, free of charge, at CONTROLS CORPORATION OF AMERICA's option, the equipment or part, which is reported to its Authorized Distributor from whom purchased, and which if so advised, is returned with a statement of the observed deficiency, and proof of purchase of equipment or part not later than seven (7) days after the expiration date of the applicable warranty, to the nearest designated service facility during normal business hours, transportation charges prepaid, and which upon examination, is found not to comply with the above warranties. Return trip transportation charges for the equipment or part shall be paid by Buyer.

CONTROLS CORPORATION OF AMERICA SHALL NOT BE OTHERWISE LIABLE FOR ANY DAMAGES INCLUDING BUT NOT LIMITED TO: INCIDENTAL DAMAGES, CONSEQUENTIAL DAMAGES, OR SPECIAL DAMAGES, WHETHER SUCH DAMAGES RESULT FROM NEGLIGENCE, BREACH OF WARRANTY OR OTHERWISE.

THERE ARE NO EXPRESS OR IMPLIED WARRANTIES WHICH EXTEND BEYOND THE WARRANTIES HEREINABOVE SET FORTH. CONTROLS CORPORATION OF AMERICA MAKES NO WARRANTY OF MERCHANTABILITY OR FITNESS FOR A PARTICULAR PURPOSE WITH RESPECT TO THE EQUIPMENT OR PARTS THEREOF.



ADI 9508-B

Certified ISO 9001:2000

Controls Corporation of America

1501 Harpers Road Virginia Beach, VA 23454

Telephone 1-800-225-0473 or 757-422-8330 • Fax 757-422-3125

www.concoa.com