

622 SERIES

Assist
Gas Supply

622 SERIES DELIVERY SYSTEM

The single-body design of the 622 offers high flow in a compact purge regulator assembly. The dome-loaded seat offers excellent flow capacity, which enables the 622 to transition into a point-of-use regulator of a bulk installation.

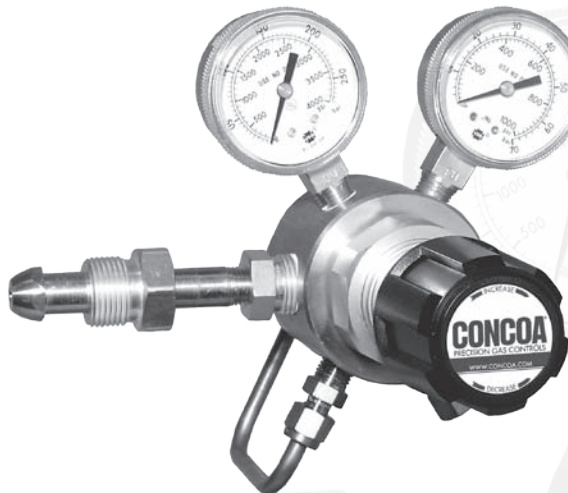

Advanced Features

- UP TO 4500 PSIG (310 BAR)** Liquid or high pressure use
- 40-MICRON INTERNAL FILTER** Limits possibility of gas contamination
- OPTIONAL WALL MOUNTING KIT** Maintains flow capacity
- RIGHT AND LEFT HAND INLETS AVAILABLE** Flexible installation options

6223503-01-580 shown

Applications	Materials	Specifications
<p>Assist Gases from Cryogenic Supply Nitrogen and Oxygen (Use low pressure inlet models for MVE Laser-Cyl™, TW™ VHP liquid cylinder, MVE Trfecta™, CTR Laser Maid™, and TW™ Laser Pak Systems)</p> <p>Assist Gas Delivery from High Pressure Supply Nitrogen and Oxygen (Use high pressure inlet models with “Gas Paks”, cradles, and tube trailers)</p>	<p>Delivery Regulator Brass barstock body and bonnet PTFE seat* or PCTFE seat† PTFE and Viton® (internal)</p> <p>Pilot Regulator Brass barstock body and bonnet PTFE seat* or PCTFE seat† PTFE and Viton® (internal)</p> <p>Tubeing and Tube Fittings 316L stainless steel</p> <p>Pressure Gauges (PSIG/BAR Dual Scale) Brass (socket) Bronze (bourdon tube) Brass (case)</p> <p>*3000 PSIG (210 BAR) †4500 PSIG (310 BAR)</p>	<p>Maximum Inlet Pressure 600 PSIG (42 BAR) 3000 PSIG (210 BAR) 4500 PSIG (310 BAR)</p> <p>Temperature Range -40 to 140°F (-40 to 60°C)</p> <p>Maximum Flow (Nitrogen) 5200 SCFH (2454 lpm)</p> <p>Inlet Connections ½" FPT</p> <p>Outlet Connections ½" MPT</p> <p>Weight 5.4 lbs. (3.5 kg)</p>

Flow Performance Curves

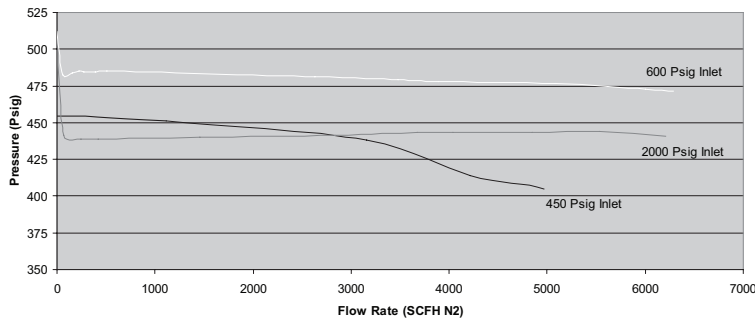

Installation Dimensions

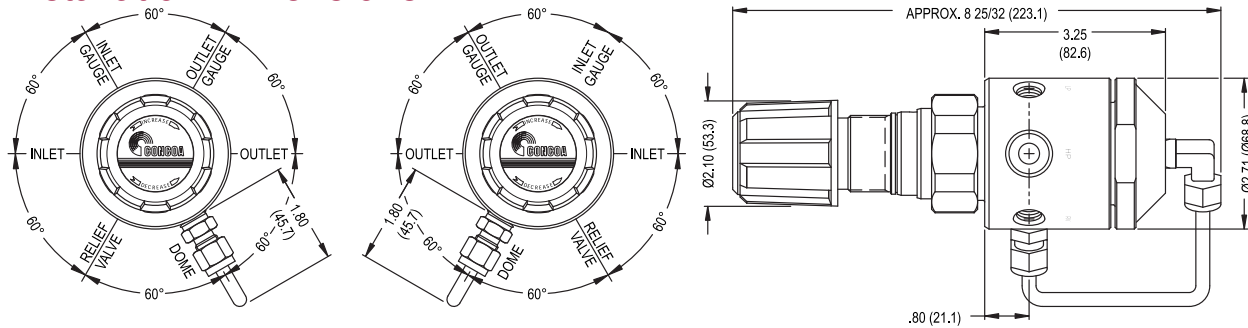

Ordering Information

622	A	B	C	D	CON	Options
Series 622	Outlet Pressure	Inlet Connection	Outlet Connection	Assembly Orientation/ Maximum Inlet Pressure	Inlet	Options
	1: 0-100 PSIG (0-0.7 BAR)	0: 1/2" FPT Port	0: 1/2" FPT Port	0: Right hand inlet/ 600 PSIG (42 BAR)	Please specify inlet connection CGA DIN 477 BS 341 and others available	W: Wall mount kit
	2: 0-250 PSIG (0-17 BAR)	1: 1/2" stainless steel tube fitting	1: 1/2" stainless steel compression tube	1: Left hand inlet/ 600 PSIG (42 BAR)		B: Two cylinders*
	3: 0-500 PSIG (0-34 BAR)	2: 12mm tube fitting	2: 12mm stainless steel compression tube	2: Right hand inlet/ 3000 PSIG (210 BAR)		C: Three cylinders*
		3: Diaphragm valve 1/2" FPT	3: Diaphragm valve 1/2" FPT	3: Left hand inlet/ 3000 PSIG (210 BAR)		D: Four cylinders
		4: Diaphragm valve 1/2" Tube	4: Diaphragm valve 1/2" tube	4: Right hand inlet/ 4500 PSIG (310 BAR)		E: Five cylinders*
		5: Cylinder connection	5: 3/8" FPT port	5: Left hand inlet/ 4500 PSIG (310 BAR)		F: Six cylinders*
		6: MicroManifold with 72" hose	6: 3/8" 37° JIC male flare			G: Seven cylinders*
		7: MicroManifold with Master Valve and 72" Hose				H: Eight cylinders*
		8: MicroManifold with P/S and 72" hose				*Valid if B=6, 7, 8 or 9
		9: MicroManifold with Master Valve, P/S and 72" hose				

Related Options

Option	Series	Description
Front Panel Mount Kit	5500002	Pilot regulator panel mount nut and washer
RH Wall Mount Kit	8309772	Wall mount bracket with pilot regulator panel mount nut and washer
LH Wall Mount Kit	8309773	Wall mount bracket with pilot regulator panel mount nut and washer