

## 655 Series Oxygen BlendMaster

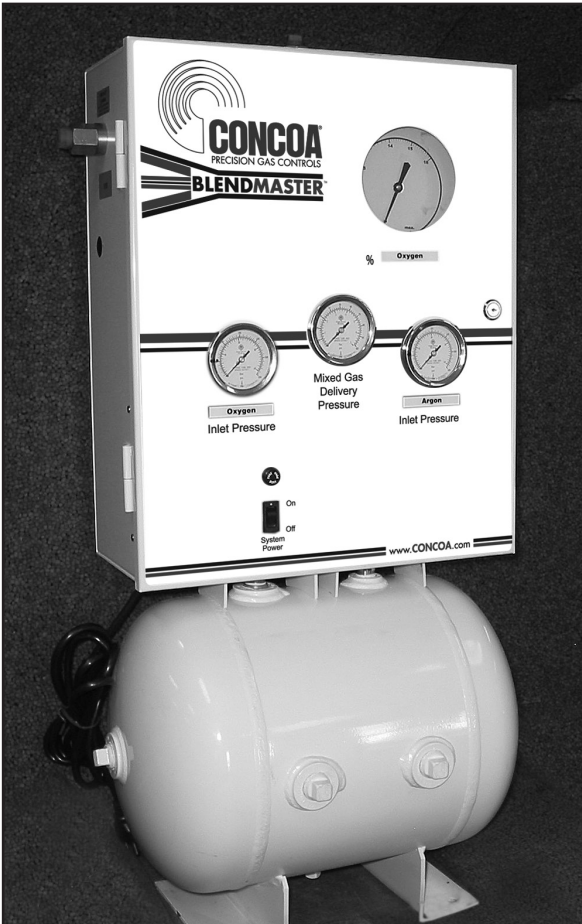

The 655 Series BlendMaster is designed to supply argon-oxygen shielding gas mixtures on-site for mild and stainless steel Mig (GMAW) welding. The blender provides up to 850 SCFH over the range of 0-10% oxygen, balance argon. Balanced stem seat inlet regulators maintain mix accuracy by eliminating pressure fluctuation effects encountered while filling micro-bulk and bulk supply sources. This makes the 655 Series BlendMaster the right choice where blend tolerances are critical to the manufacturing process.

### Advanced Features

- **Lockable Enclosure**  
Process control
- **0 - 10% Ratio Adjustability**  
Process flexibility
- **Wall or Bench Mountable**  
Installation flexibility
- **Integral Line Regulator**  
Supports flowmeter and regulator/flowmeter installations

### Applications

#### Stainless Steel

0-1% Oxygen  
Stabilized spray transfer

1-2% Oxygen  
Spray transfer with enhanced wetting action

#### Mild Steel

2-3% Oxygen  
Spray transfer with enhanced wetting action

3-5% Oxygen  
High travel speeds with fluid weld puddle

### Materials

#### Case

Powder-coated steel  
Not designed for use outdoors

#### Surge Tank

Seven gallon (26.5 Liters)

#### Pressure Control Mechanism

Brass barstock  
Gas piloted

### Specifications

#### Flow Capacity

850 SCFH (24.1 M<sup>3</sup>/H)

#### Inlet Supply Pressure Requirements

100 - 125 PSIG (7 - 8.6 BAR)

#### Mixed Gas Outlet Pressure

10 - 45 PSIG (.7 - 3.1 BAR)

#### Power Requirements

110/220 VAC (50 - 60 Hz)

#### Ambient Atmosphere and Gas Supply

##### Temperature

32°F to 100°F (0°C to 38°C)

##### Accuracy

± 0.5%

##### Weight

102 lbs. (46 kg)

## Available Mounting Information for the 655 Series BlendMaster

Gas Blending

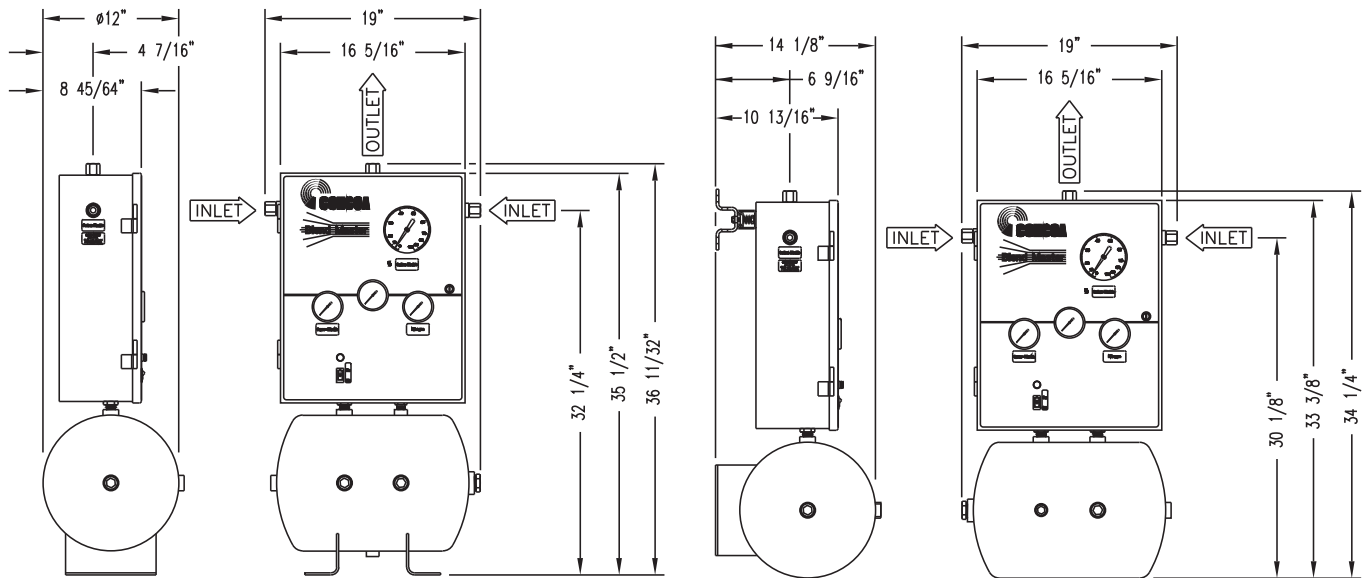

Floor-Mounted

Wall-Mounted

### Ordering Information

Series	A Primary Scale Major Gas	B Primary Scale Minor Gas	C Monitoring	D Assembly
655	1: Argon	1: Oxygen	0: No Alarm 7: Low Pressure Alarm Capability*	1: 110V, Floor Mount 2: 110V, Wall Mount 5: 220V, Floor Mount 6: 220V, Wall Mount

\* Alarm sold separately

### Related Options

Option	Order Number	Description
Advantium 2 Remote Alarm	575-0023-01-000	Provides audible and visual notification of a depleted supply bank to a remote location. (See page 48 for full list of options)