



1600 Series Dual-Range Flowmeters

INSTALLATION AND OPERATION INSTRUCTIONS

Before Installing or Operating, Read and Comply with These Instructions

Controls Corporation of America
1501 Harpers Road Virginia Beach, VA 23454
To Order Call 1-800-225-0473 or 757-422-8330 • Fax 757-422-3125
www.concoa.com

THIS PAGE INTENTIONALLY LEFT BLANK

USER RESPONSIBILITY

This equipment will perform in conformity with the description contained in this manual and accompanying labels and/or inserts when installed, operated, maintained, and serviced in accordance with the instructions provided. This equipment must be checked periodically. Defective equipment should not be used. Parts that are broken, missing, plainly worn, distorted or contaminated should be replaced immediately. Should such repair or replacement become necessary, CONCOA recommends that a telephonic or written request for service advice be made to the CONCOA Authorized Distributor from whom purchased.

This equipment or any of its part should not be altered without prior written approval of CONCOA. The user of this equipment shall have the sole responsibility for any malfunction which results from improper use, faulty maintenance, damage, improper repair or alteration by anyone other than CONCOA or a service facility designated by CONCOA.

GENERAL SAFETY PROCEDURES

Protect yourself and others. Read these instructions completely before installing, operating, or servicing this equipment. Be sure these instructions reach the user. Additional copies may be obtained from your CONCOA supplier.

Do not exceed 50 PSIG pressure in the flowmeter. Flowmeter is designed to operate at 30 PSIG. Excessive pressure could explode flowmeter.

Do not flow mixed gases that are combustible or can chemically react with each other through the flowmeter.

Do not use flowmeter for the production of combustible or reactive mixtures.

Do not flow oxygen through any flowmeter or equipment that is not labeled for oxygen service or has flowed any other gas.

INTRODUCTION

The CONCOA 1600 Series Dual-Range Flowmeter is for use in the metering of gas in applications where control and constant visual check of flowrate, in standard cubic feet per hour, are required. A control valve regulates rate of flow in either high or low range, and a selector valve provides instant, in-service switching from one flow range to the other. Back pressure to the flowmeter does not affect its accuracy. To ensure the accuracy of the calibrated flowmeter, inlet pressure must be 30 PSIG. When pipeline pressure is regulated to 30 PSIG, install a shutoff valve prior to the flowmeter. When pipeline pressure may exceed 30 PSIG, install a pressure regulator to maintain 30 PSIG pressure prior to the flowmeter.

This flowmeter, in combination with one or more additional flowmeters of its type, can be used for proportioning a number of gases. Only produce noncombustible mixtures.

A unique feature of this device is the inlet connection assembly enables the flowmeter to be placed in a vertical position regardless of the angle of projection of the gas supply outlet.

| Gas Service | Flowmeter Stock No. | High Range (SCFH) | Low Range (SCFH) |
|--------------------|----------------------------|-----------------------------------|-------------------------|
| Argon | 805-1601 | 22-198 | 1-24 |
| Helium | 805-1600 | 30-200 | .5-37 |
| Oxygen | 805-1602 | 3.5-20 | .1-4.5 |
| Hydrogen | 805-1604 | 40-300 | 2-52 |
| Nitrogen | 805-1603 | 27-245 | 1-29 |
| Carbon Dioxide | 805-1605 | 23-150 | 1-24 |
| General Purpose | 805-1606 | See Calibration Curves on Page 13 | |

Table 1. 1600 Series Flowmeters.

CUSTOMER SERVICE

In the event of equipment failure, call the CONCOA Customer Assistance Line (1-800-225-0473) or via E-MAIL at *e-mail@concoa.com* or by FAX (1-757-422-3125). Please be prepared to provide the model number and serial number of the equipment involved, in addition to some details regarding its application.

INSTALLATION

Bench or Panel Mounting

If the flowmeter is to be mounted on a bench, panel or similar location, and the flowmeter is located away from the regulator or gas source, remove the connector assembly (Figure 1) and connect the inlet connection to the regulator or gas source by a suitable hose. Connect the flowmeter outlet by a length of suitable hose to the equipment to be supplied with gas. If the calibrated side of the tube is located such that reading is difficult, the tube may be rotated with the casing. For directions to rotate the tube, refer to the MAINTENANCE paragraph, CASING, TUBE, FLOAT AND ASSOCIATED REPLACEMENT PARTS.

Pipeline or cylinder mounting

To mount the flowmeter to a pipeline or cylinder, mount as follows (Figure 1 or 2):

- a. Loosen the nut that fastens the inlet connection to the body.
- b. Finger tighten the flowmeter inlet to the outlet of any suitable regulator or pipeline.
- c. Position the flowmeter so the scaled tube is on top and vertical.

- d. Tighten both nuts on the connection assembly, being careful to keep the tube vertical.
- e. Connect the flowmeter outlet by a length of suitable hose to the equipment to be supplied with gas.
- f. If the calibrated side of the tube is located such that the reading is difficult, the tube may be rotated within the casing. For directions to rotate the tube, refer to the MAINTENANCE paragraph, CASING, TUBE, FLOAT AND ASSOCIATED REPLACEMENT PARTS.

Combination Mounting

When a combination of flowmeters is used to proportion gases, a flowmeter of the type designated for use with each gas involved must be used.

Proceed as follows:

- a. Connect each of the flowmeters to its respective gas source as described in the preceding paragraphs.
- b. Connect the outlet of each to a “Y” connection, manifold, or other suitable device that will function as a mixing chamber.

OPERATION

CAUTION: Under no circumstances should this flowmeter be used for combustible mixtures or production of combustible mixtures. Such service would require safety devices not incorporated in this flowmeter.

The inlet pressure must never exceed 50 pounds per square inch, gauge (PSIG).

General

- a. A constant inlet pressure of 30 PSIG is required; other pressures will introduce error in the meter readings.
- b. The flowmeter should be used only for the gas that it is designated. Other gases will introduce error in the meter readings.
- c. Always check the flowmeter for gas tightness on installation and periodically thereafter, particularly when readjusting.

Single Flowmeters

To put the flowmeter into operation, proceed as follows:

- a. Refer to Table I to determine which flow range (standard cubic feet per hour) is to be used, as indicated by the volume of gas required. If the required volume is greater than that indicated in the Table, refer to the paragraph on combination of flowmeters.
- b. Set the selector valve (Figure 1) for the proper range. For high-range service, the valve must be all the way out; for low-range service, all the way in.

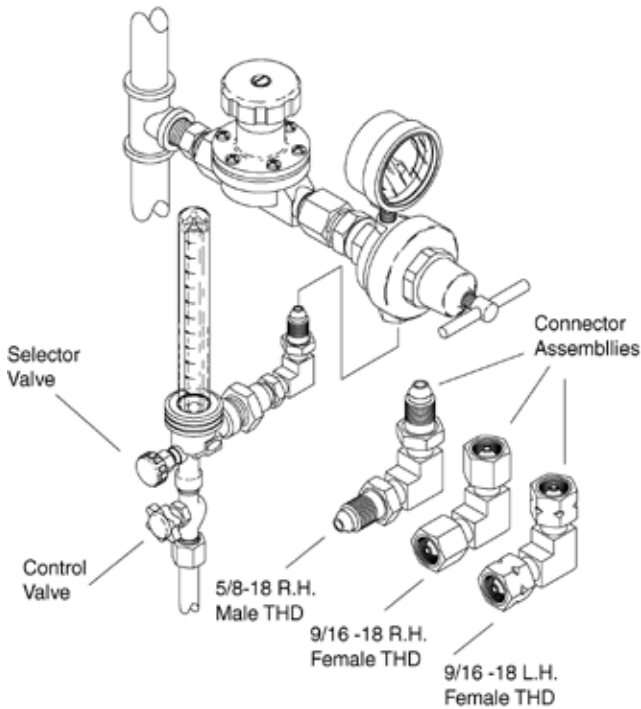

Figure 1. Dual Range Flow Meters 1600 Series

To reset the valve from the low-range (in) setting to the high-range setting (out), unlock the valve by turning the valve handle counterclockwise until the threads on the stem disengage, and pull the stem outward as far as it will come. The stem has a mechanical stop which prevents it from being pulled out of the flowmeter body.

IMPORTANT

If excessive force is used in pulling the valve open, damage may be caused to the valve.

To change the selector valve from the high-range (out) setting to the low-range (in) setting, push the stem in as far as it will go and lock the valve in position by turning the valve handle clockwise until it is drawn up firmly.

IMPORTANT

The selector valve is of the piston type. Application of torques greater than that necessary to engage the threads in the normal manner will not aid in making the valve tight but may cause damage to the valve.

- c. Turn the control valve (Figure 1) clockwise to the closed position. Avoid overtightening which may damage it.
- d. Admit gas at a pressure of 30 PSIG to the flowmeter inlet. For most applications, variation in the inlet pressure of as much as ± 4 or ± 5 PSIG can be tolerated. For extreme accuracy, however, the variations must be

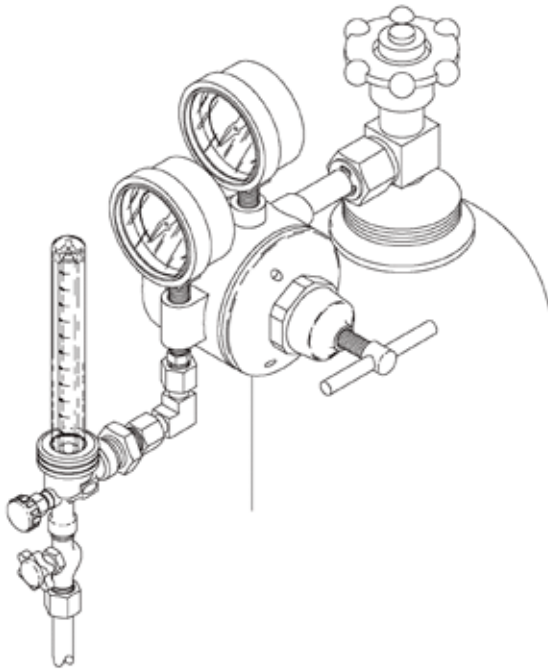

Figure 2. Flowmeter Cylinder Mounted.

- held within narrower limits.
- e. Open all valves on equipment downstream of the flowmeter.
 - f. Slowly open the flowmeter control valve by turning it counterclockwise. This valve is very sensitive; minor adjustments of it will vary the meter reading considerably. Adjust it so that the center of the ball float indicates the required flow.
 - g. With gas flowing through the system, it may be necessary to readjust the inlet (regulator) pressure to 30 PSIG and then readjust the control valve.
 - h. Flow is indicated in standard cubic feet per hour (scfh) on the appropriate scale by the center of the ball float. The calibrated scale is direct-reading (except for the general purpose model, with which calibration curves are provided for all of the commonly used inert gases).
 - i. After changing from one flow range to the other, it may be necessary to adjust the regulator to re-establish the proper delivery pressure.

Combination of Flowmeters

For gas flows in excess of those specified in Table 1, two or more flowmeters may be operated in parallel from a number of cylinders of same gas or from a pipeline.

When operating two or more flowmeters in the same system, whether for one gas or to proportion gases for a mixture, treat each flowmeter in the setup individually; the operation of each should be in accordance with the procedure specified for single flowmeters. The total gas flow will equal the sum of the indicated flows from

each of the flowmeters in the system. See Figure 3 for an illustration of multiple flowmeter installation.

MAINTENANCE

Shutdown Procedure

To shut down for a short period:

- a. Close the valve(s) at the gas source(s).
- b. Close the valve(s) on the equipment downstream of the flowmeter(s).

IMPORTANT

If only the downstream valve(s) is closed, excessive pressure could build up in the line if regulating equipment were faulty. In dual-gas service, closing only the downstream valve(s) might, under certain circumstances, result in backfeeding and contamination of one gas with the other.

To shut down for an extended period, such as overnight:

- a. Close the valve(s) at the gas source(s).
- b. Close the valve(s) on equipment downstream of the flowmeter(s).
- c. Close the control valve(s) of the flowmeter(s).

General

In normal service, this flowmeter should require no maintenance other than infrequent inspection of the filter and relubrication of the selector valve.

If, with the gas-source valve wide open and the regulator indicating the proper delivery pressure of 30 PSIG, it is impossible to obtain or maintain the required flow rate from the flowmeter, the condition may be caused either by excessive flow resistance downstream of the flowmeter, or by dirt accumulation in the filter.

Flowmeter and connections should be routinely checked for leaks.

Filter Inspection

In general, filter condition will depend on the degree of cleanliness of the upstream system. The first filter inspection should be made when the unit has been in service six months. Subsequent inspections should be made as indicated by the condition of the filter at the first inspection.

Valve Lubrication

If the selector valve gradually stiffens in operation, the selector valve o-rings should be relubricated. Refer to the paragraphs on Disassembly Techniques and Selector Valve.

Disassembly Techniques

It is essential to prevent dust, lint or other minute particles from entering the flowmeter and being carried into the calibrated tube. Such particles adhering to the tube walls or to the float might interfere with the motion of the ball float. Particles of an

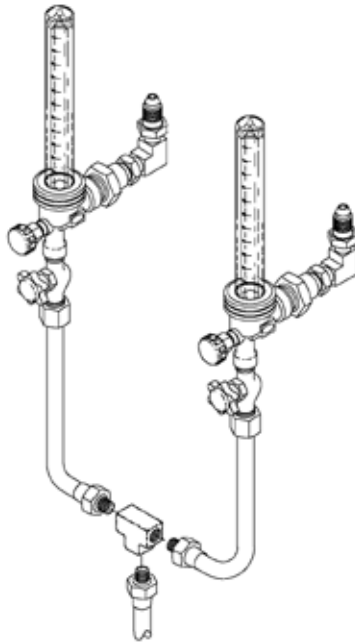

Figure 3. Two flowmeters into one outlet.

abrasive nature could eventually damage the ball float or tube wall. Therefore, when disassembling the flowmeter, use extreme care to keep all parts clean. Work on a clean bench, and with clean tools; lay parts on a clean cloth rather than on the bench surface.

Before reassembly, remove dirt or grease, which is not readily removable with a lint-free cloth and from the body and parts with a cloth dampened with a nonhydrocarbon detergent.

Lightly wet all O-rings and the quad ring with a film of Fluorolube or Halocarbon oxygen compatible oil before reassembling them into the unit.

Caution

This lubricant, when used sparingly, is approved for use in oxygen service; it is recommended that no other be used.

Casing, Tube, Float and Associated Parts Replacement

- a. Lightly clamp the body of the flowmeter (at the flats on the sides of the body) in the padded jaws of a vise with the casing and calibrated tube approximately vertical.
- b. By hand, loosen (turn counterclockwise) the collar at the base of the tube.

IMPORTANT

Never retighten the collar without being certain that the tube is properly seated at both ends. Carelessness may result in a broken tube.

- c. Completely unscrew the collar and lift the casing, collar and tube away from the body. Be careful not to lose the small-tube gasket, which may adhere to the lower end of the tube. The parts thus removed can be easily separated; the cap can be shaken from the casing. The lower stop is either a plastic insert or part of the tube, and the upper stop is a plastic or metallic insert. Do not remove the ball float stop(s) from the tube; loss or impact damage to the ballfloat could result. A damaged ball float will give inaccurate flowmeter readings.
- d. Lift the large O-ring out of its seat in the body.
- e. Remove the flowmeter body from the vise and tap the casing seat against the palm of the hand to dislodge the small-tube gasket (if adhered to its seat), button and support spring.
- f. Before reassembly, inspect the O-rings and replace any that are damaged. Lubricate the O-rings, and wipe the body and all the parts clean. Wash the casing, cap, float stop, tube and float in a nonhydrocarbon detergent; if practicable, run the solution through the tube. Be sure these parts are absolutely clean before reassembling them.
- g. Repeat step a.
- h. Seat the support spring in place in the hole in the body.
- i. Fit the button with the O-ring in place, into the body. For the oxygen flowmeter with the smaller tube (5/16" outside diameter) insert the button with the recessed end up; for all other flowmeters with the larger tube (7/16" outside diameter) insert the button with the flat end up. Push the button down onto the spring.
- j. Place the small-tube gasket on the button, then fit the large O-ring into its seat in the body.
- k. Fit the cap, flat side first, into the casing and seat it properly. Hold the casing with the open end up, and slide the collar up around it; hold the assembly by the collar. Invert the calibrated tube with float and float stop(s) in place, and seat it on the cap.
- l. While holding the collar and casing in one hand, with the other hand guide the end of the calibrated tube into its seat in the body. Turn the tube until the numbers face in the proper direction for reading the scale after the flowmeter is reconnected to the gas source.
- m. Engage the threads. Be sure the tube is properly seated at both ends. Slowly finger tighten the collar while observing the tube seating. Hand tighten the collar. The spring-loaded button will accommodate the tube and hold it firmly in place.

Problems Indicating Service Need

Should the flowmeter leak or the valve does not shut off, discontinue use and have the flowmeter serviced by service facility authorized by CONCOA.

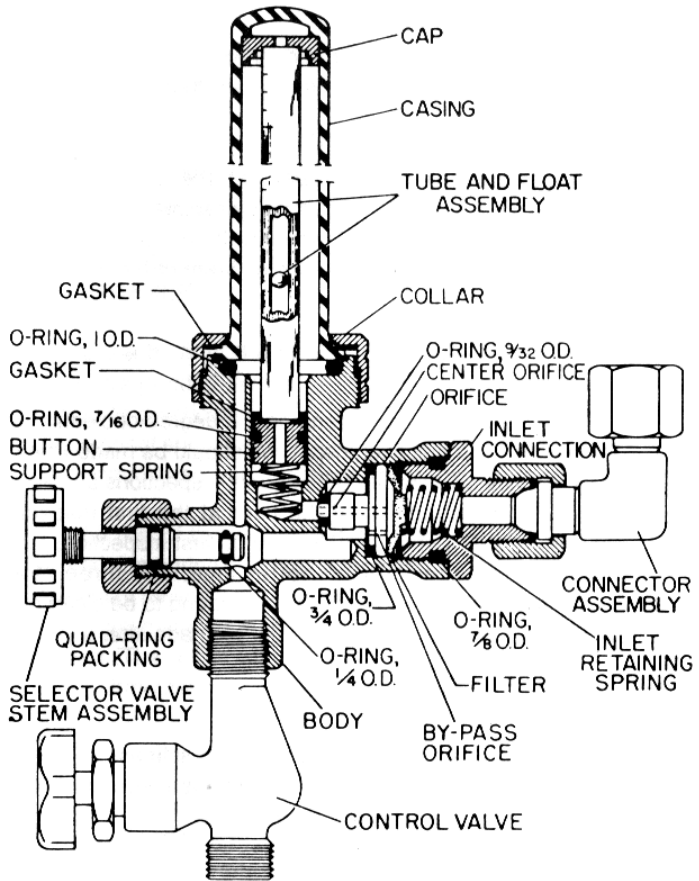

Figure 4. Flowmeter Components

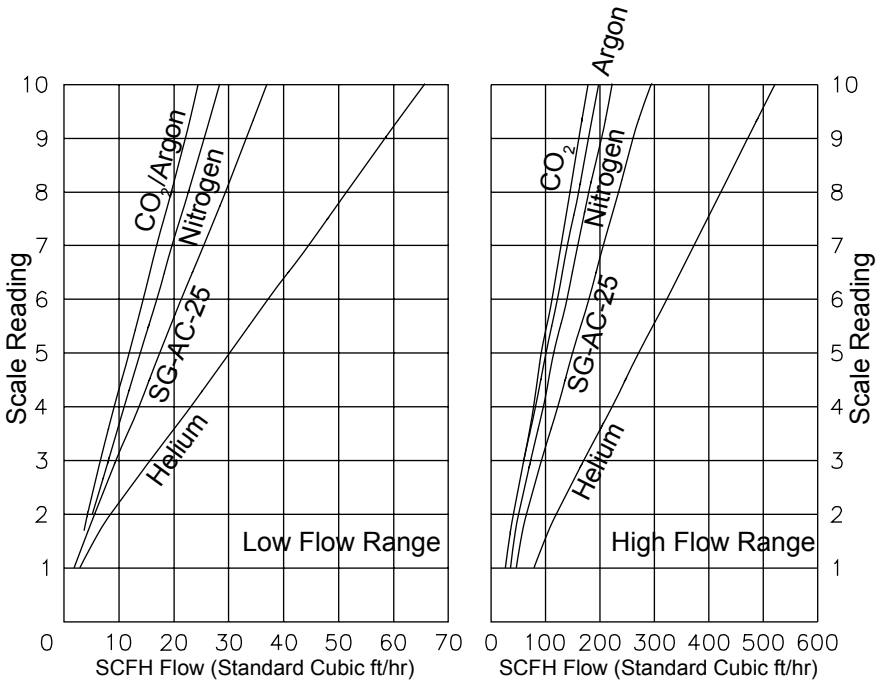

Figure 5. Calibration Curves fro General Purpose Flowmeter

Warranty Information

This equipment is sold by CONTROLS CORPORATION OF AMERICA under the warranties set forth in the following paragraphs. Such warranties are extended only with respect to the purchase of this equipment directly from CONTROLS CORPORATION OF AMERICA or its Authorized Distributors as new merchandise and are extended to the first Buyer thereof other than for the purpose of resale.

For a period of one (1) year from the date of original delivery (90 days in corrosive service) to Buyer or to Buyer's order, this equipment is warranted to be free from functional defects in materials and workmanship and to conform to the description of this equipment contained in this manual and any accompanying labels and/or inserts, provided that the same is properly operated under conditions of normal use and that regular periodic maintenance and service is performed or replacements made in accordance with the instructions provided. The foregoing warranties shall not apply if the equipment has been repaired: other than by CONTROLS CORPORATION OF AMERICA or a designated service facility or in accordance with written instructions provided by CONTROLS CORPORATION OF AMERICA, or altered by anyone other than CONTROLS CORPORATION OF AMERICA, or if the equipment has been subject to abuse, misuse, negligence or accident.

CONTROLS CORPORATION OF AMERICA's sole and exclusive obligation and Buyer's sole and exclusive remedy under the above warranties is limited to repairing or replacing, free of charge, at CONTROLS CORPORATION OF AMERICA's option, the equipment or part, which is reported to its Authorized Distributor from whom purchased, and which if so advised, is returned with a statement of the observed deficiency, and proof of purchase of equipment or part not later than seven (7) days after the expiration date of the applicable warranty, to the nearest designated service facility during normal business hours, transportation charges prepaid, and which upon examination, is found not to comply with the above warranties. Return trip transportation charges for the equipment or part shall be paid by Buyer.

CONTROLS CORPORATION OF AMERICA SHALL NOT BE OTHERWISE LIABLE FOR ANY DAMAGES INCLUDING BUT NOT LIMITED TO: INCIDENTAL DAMAGES, CONSEQUENTIAL DAMAGES, OR SPECIAL DAMAGES, WHETHER SUCH DAMAGES RESULT FROM NEGLIGENCE, BREACH OF WARRANTY OR OTHERWISE.

THERE ARE NO EXPRESS OR IMPLIED WARRANTIES WHICH EXTEND BEYOND THE WARRANTIES HEREINABOVE SET FORTH. CONTROLS CORPORATION OF AMERICA MAKES NO WARRANTY OF MERCHANTABILITY OR FITNESS FOR A PARTICULAR PURPOSE WITH RESPECT TO THE EQUIPMENT OR PARTS THEREOF.

THIS PAGE INTENTIONALLY LEFT BLANK

THIS PAGE INTENTIONALLY LEFT BLANK



Controls Corporation of America
1501 Harpers Road Virginia Beach, VA 23454
To Order Call 1-800-225-0473 or 757-422-8330 • Fax 757-422-3125
www.concoa.com

May 2007
Supercedes November 2000