



Certified ISO 9001

Instruction 3240C

Fully Automatic AutoSwitch 2

For use with Gases in High Purity Applications

(Non-Toxic, Non-Flammable, and Non-Corrosive)

INSTALLATION AND OPERATION INSTRUCTIONS

Before Installing or Operating, Read and Comply with These Instructions

Controls Corporation of America
1501 Harpers Road Virginia Beach, VA 23454
To Order Call 1-800-225-0473 or 757-422-8330 • Fax 757-422-3125
www.concoa.com

June 2024

WARNING

An appropriately sized pressure relief device downstream of the AutoSwitch 2 system should be installed in your system to prevent damage to equipment and/or injury to personnel should an internal failure of the system occur.

WARNING

Maximum allowable working pressure indicated on product labeling is for the AutoSwitch 2 system only. Ratings for peripherals/accessories may be less than the pressure indicated on the product label. Do not exceed the pressure ratings of the attached peripherals/accessories and the system's maximum allowable working pressure. Please contact your gas supplier for more information.

WARNING

AutoSwitch 2 systems with tube fittings, select the appropriate tubing. Use seamless tubing with the proper consideration given to wall thickness and material. Please contact your gas supplier for more information.

Contents

USER RESPONSIBILITY	3
SAFETY INSTRUCTIONS	3
DESCRIPTION OF PRODUCT	6
FEATURES	6
INSTALLATION	9
ELECTRONIC OUTPUTS	14
USER INTERFACE	17
MAINTENANCE	20
TROUBLESHOOTING	20
SERVICE	22
ADVANCED SETTINGS	24
WARRANTY INFORMATION	31

USER RESPONSIBILITY

The User of this equipment shall:

- Follow all labeling, installation and operation instructions when using this equipment.
- Review all safety precautions listed in the safety section of this manual.
- Understand the properties and special handling requirements of the gas being used. Many gases are dangerous. **This product is not intended for use with flammable, toxic, or corrosive gases.**
- The system must be installed indoors.
- System should not be placed in locations where the temperature will exceed 90°F (32°C) or fall below 60°F (16°C).
- Check this equipment periodically. The user shall not use improperly working equipment.
- Immediately replace broken, worn, distorted, contaminated, or missing components and ONLY by a trained technician.
- Service to this product should only be performed by CONCOA or an authorized CONCOA agent. Requests for service may be made through CONCOA CUSTOMER SERVICE at 1-800-225-0473. Written requests may be made using CONCOA's FAX number at 1-757-422-3125 or CONCOA's E-MAIL at info@concoa.com
- CONCOA accepts no responsibility for damage or injury if this product is modified in any way.
- CONCOA assumes/accepts no liability or responsibility for damage to individuals or equipment that may occur when using this product.

SAFETY INSTRUCTIONS

Read these instructions carefully. Keep this document for future reference. Follow all warnings and instructions marked on the product.

NOTICE: The AutoSwitch 2 is not intended for use with toxic, flammable, or corrosive gases.

Basic safety precautions must be followed to reduce the risk of fire, electrical shock or injury.

- Connect the AutoSwitch 2 to the correct voltage as stated in the Installation section.



CONNECTION TO AN INCORRECT VOLTAGE CAN CAUSE SERIOUS DAMAGE TO THE PRODUCT OR USER AND WILL VOID ANY WARRANTY.

- Install the AutoSwitch 2 where the ambient temperature range is between 90°F (32°C) and 60°F (16°C).
- Do not install this product in a hazardous environment.
- If product appears damaged in any way, do not use and request service per the Service section.
- Consult the cylinder distributor for the proper use of cylinders and for any restrictions on their use (such as flow rate and temperature requirements).

- Store cylinders with valve caps screwed on, and chain cylinders to a supporting wall or column.
- Handle cylinders carefully and only with valve caps screwed on. The cap will reduce the chance that the cylinder valve will break off if the cylinder is accidentally dropped or falls over. The cap also protects the cylinder valve from damage to screw threads, which could cause leaky connections.
- No smoking should be permitted near oxygen, nitrous oxide, any other oxidizer, flammable gases, or flammable mixtures, or in areas where cylinders are stored.
- Where an oxidizer (such as nitrous oxide or oxygen) is used, the manifold and cylinders must be kept clean. No oil, grease, or combustible substances should come in contact with oxygen or nitrous oxide storage or handling equipment. Such materials in contact with oxygen or nitrous oxide are readily ignitable and, when ignited, will burn intensely.
- Never lift gas cylinders with a magnetic lifting device.
- Never use an open flame when leak testing.
- Always open valves slowly when high-pressure gases are being used.
- Always be sure that a cylinder contains the correct gas before connecting it to any manifold.
- Always leak-test any manifold or distribution pipeline before using.
- Always be sure that the gas in a pipeline is the correct gas for the intended use.
- Always close all cylinder valves before disconnecting cylinders from a manifold.
- Always remove all empty cylinders from a manifold before connecting full cylinders.
- Always test cylinders to be sure the cylinders are full before connecting to a manifold.



If not using CONCOA supplied manifold system or flexible hoses that include check valves, user must INSTALL CHECK VALVES ON THE INLETS.

All gas distribution piping systems must meet the appropriate industrial standards for the intended service and must be thoroughly cleaned before using. For the United States, some applicable safety rules and precautions are listed below:

1. American National Standards Institute standard Z49.1, Safety in Welding and Cutting, American Welding Society, 2501 NW Seventh Street, Miami, Florida 33125
2. N.F.P.A. Standard 51, Oxygen-Fuel Gas systems for Welding and Cutting, N.F.P.A., 470 Atlantic Avenue, Boston, Massachusetts 02210
3. N.F.P.A. Standard 51B, Cutting and Welding Processes (same address as #2).
4. CONCOA publication ADE 872, Safety Precautions in Welding and Cutting.
5. Local Ordinances
6. O.S.H.A. Standard 29 CFR
7. C.G.A. Pamphlet C-4, American National Standard Method of Marking Portable Compressed Gas Containers to Identify the Material Contained.
8. C.G.A. Pamphlet G-4, Oxygen – Information on the properties, manufacture, transportation, storage, handling, and use of oxygen.
9. C.G.A. Pamphlet G-4.1, Equipment Cleaned for oxygen service.
10. C.G.A. Pamphlet G-4.4, Industrial Practices for Gaseous Oxygen Transmission and Distribution Piping Systems.
11. C.G.A. Pamphlet G-5, Hydrogen – Information on the properties, manufacture, transportation, storage, handling, and use of hydrogen.
12. C.G.A. Pamphlet G-6, Carbon Dioxide – Information on the properties, manufacture, transportation, storage, handling, and use of carbon dioxide.
13. C.G.A. Pamphlet G-6.1, Standard for Low Pressure Carbon Dioxide Systems at Consumer Sites.
14. C.G.A. Pamphlet P-1, Safe Handling of Compressed Gases in Containers.
15. C.G.A. Safety Bulletin SB-2, Oxygen Deficient Atmospheres.

C.G.A. Pamphlets can be obtained from the Compressed Gas Association, 1235 Jefferson Davis Highway, Arlington, VA 22202-3239, (703) 979-0900. Publications: (703) 979-4341. Fax: (703) 979-0134.

DESCRIPTION OF PRODUCT

The AutoSwitch 2 is an automatic switchover system designed to provide a continuous supply of high purity gas. It can be used with one cylinder per side, or used with a manifold that has increased storage capacity. The inlet of the automatic switchover system may be configured with open ports, diaphragm valves, manifold connectors, or flexible hoses. The system, when configured with manifold connectors, is for use with the 52B (brass), 52C (chrome) or 52S (stainless steel) series manifold systems. See catalog or web-site for full product offering / options.

The standard AutoSwitch 2 system maintains a regulated line pressure within the values shown in the table below:

Model	Description	Outlet Pressure Range
5821xxx	Brass Automatic Switchover	0-100 PSIG (0-7 BAR)
5822xxx	Brass Automatic Switchover	0-200 PSIG (0-14 BAR)
5823xxx	Brass Automatic Switchover	0-350 PSIG (0-24 BAR)
5831xxx	Stainless Automatic Switchover	0-100 PSIG (0-7 BAR)
5832xxx	Stainless Automatic Switchover	0-200 PSIG (0-14 BAR)
5833xxx	Stainless Automatic Switchover	0-350 PSIG (0-24 BAR)

FEATURES

Modes of Operation

See System/Service Menus – Switchover Mode for configuring this setting. Note that the left side should be set up as the main source.

- **Full Automatic (default)**

Full Automatic Mode monitors the pressures in both banks of the switchover system. The side 'In Use' will deplete over time. When the pressure reaches the switchover pressure, the AutoSwitch 2 will automatically switch to the other side 'In Use'. The depleted bank, when replaced will then be available when the current 'In Use' side depletes. Other than changing the tanks on the depleted side, there is no user intervention required on the AutoSwitch 2 automatic switchover system. In addition, the following cases will auto-switch to the left main side:

- On power up if both sides have more than 2000 PSIG.
- If both sides go from "Replace" to "Ready" within 15 minutes.

- **Primary LEFT**

Primary LEFT Mode uses the left side as primary, and the right side as reserve. The AutoSwitch 2 automatically prioritized the Left Primary side as 'In Use' if the pressure in that bank is above the switchover pressure. When depleted, the system will automatically switch to the Right Reserve side 'In Use' until the tanks are replaced on the Left Primary side. Once Primary pressure has been restored, the AutoSwitch 2 will automatically go back to the Left Primary side.

Electronic Outputs

- Four dry-contact relays to indicate alarm conditions for the AutoSwitch 2 are provided. See Connecting to Dry Contacts.
- Three 4-20 mA transducer output circuits are provided to transmit the pressure shown on the front of the AutoSwitch 2 to a remote alarm such as the Altos 2 Remote Alarm. See Connecting to 4-20 mA Transducer Outputs.

Graphical Status Display and User Interface

The AutoSwitch 2 contains a built in graphical status display and user interface. The status display clearly shows the current state of the automatic switchover system. It provides menu options to make several features customer configurable. These include:

- Switchover pressure – The pressure at which the AutoSwitch 2 automatically changes from the ‘In Use’ bank to the other bank. See Setting Menu for Left Inlet and Right Inlet – Replace Set Point. The “Replace Pressure” is configurable with the following limits and defaults:

MODEL	MINIMUM ALLOWED	DEFAULT
582/3 1xxx	325 PSIG (22 BAR)	375 PSIG (26 BAR)
582/3 2xxx	395 PSIG (27 BAR)	445 PSIG (31 BAR)
582/3 3xxx	565 PSIG (39 BAR)	615 PSIG (42 BAR)

- Units of Measure – Users can select from PSIG, BAR, or MPA units of measure – default is PSIG. See Setting Menu for Left Inlet, Right Inlet, and Outlet - Units of Measure option on each.
- Deadband – The value of the deadband is the amount above the switchover pressure that the AutoSwitch 2 automatic switchover system will consider a bank replaced. Factory set to optimize gas usage from cylinders. See System/Service Menus – Left/Right/Outlet Deadband.

Other features:

- Manual Bank Selection – it is possible to manually switch between banks on the AutoSwitch 2 by using the “BANK SELECT” button on the front of the unit. This feature will not switch to a bank that is in “REPLACE”.
- Security Lockout – the AutoSwitch 2 can lockout the front panel buttons to prevent any unintentional changes to the system. By default, this feature is disabled. To enable see Security Lockout Instructions.
- Relief Valve – The AutoSwitch 2 is equipped with a pipe-away outlet pressure relief valve. This is intended to protect the AutoSwitch 2 and not downstream equipment.



An appropriately sized pressure relief device downstream of the AutoSwitch 2 system should be installed in your system to prevent damage to equipment and/or injury to personnel should an internal failure of the system occur.

Front Overview of the AutoSwitch 2:

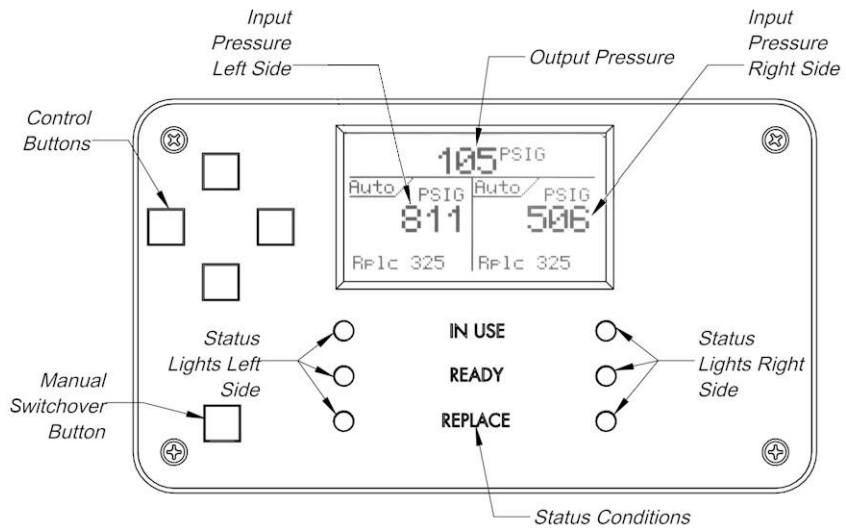
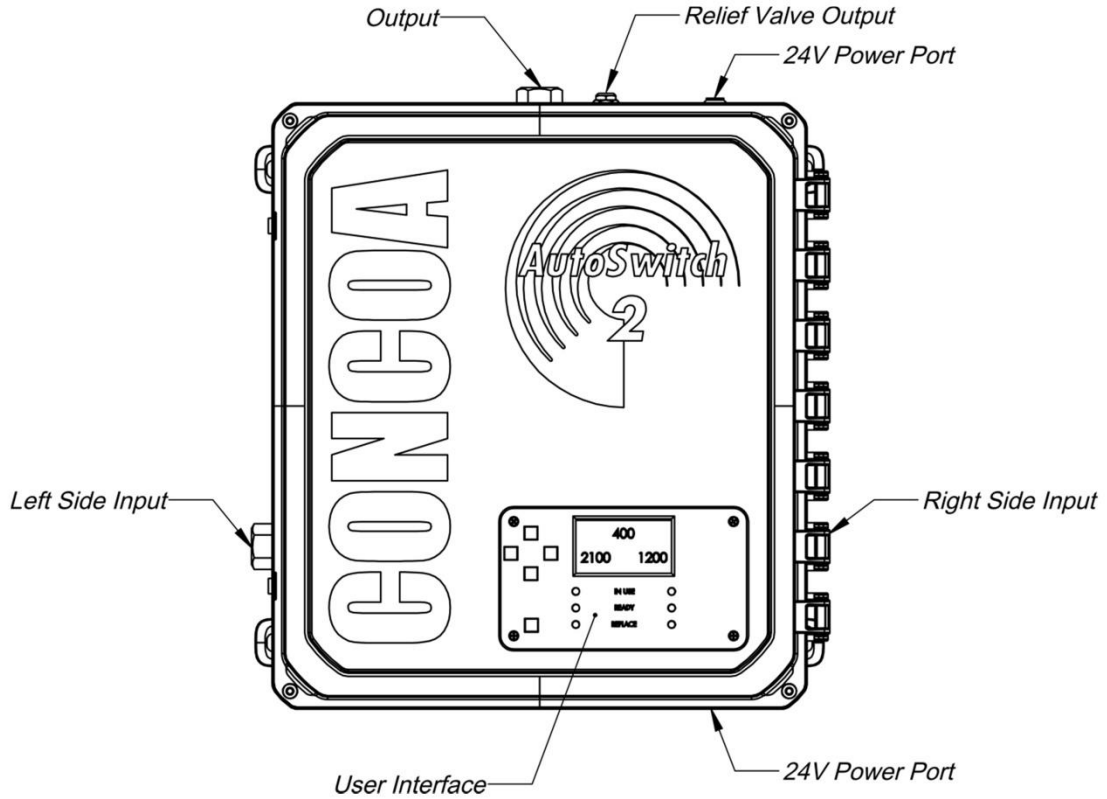

INSTALLATION

For proper installation, follow all guidelines listed below:

- The system must be installed indoors.
- The site chosen for the installation of the system shall be level, well ventilated, and at a safe distance from sources of flames, sparks, and excessive heat.
- The system shall not be placed in an area that may subject it to damage from passing trucks, cranes, or other heavy machines.
- Any oxygen system shall not be installed under shafting, belting, or other places where oil can drip on it.
- When installing the manifold(s), reference the Manifold Instructions.
- Be sure to consider all factors when selecting materials.
- Do not use oil or grease on fittings.
- Be sure that all fittings are secure and leak tight. Polytetrafluoroethylene (PTFE) tape should be used on pipe threads. See PTFE taping instructions.
- The AutoSwitch 2 relief valve has a female 1/4" NPT exhaust port at the top of the enclosure to vent the relief valve to a safe place.
- Once all mechanical connections are made, pressurize the system and check for leaks.

WARNING

Equipment failure or misuse may lead to problems such as a release of gas through the relief valve or regulator diaphragm. The AutoSwitch 2 box is not sealed and will leak gas from faulty components. Proper safety measures should be established to handle these and other component failures.

WARNING

An appropriately sized pressure relief device downstream of the AutoSwitch 2 system should be installed in your system to prevent damage to equipment and/or injury to personnel should an internal failure of the system occur.

CAUTION

All gas and electrical connections should be done with the power off, and no pressure applied to the system. Note that the product itself does not have internal check valves.

CAUTION

If not using CONCOA supplied manifold system or flexible hoses that include check valves, user must **INSTALL CHECK VALVES ON THE INLETS.**

Wall Mounting

The AutoSwitch 2 uses four mounting tabs to secure to a wall or to a panel – See diagram below for dimensions. Mount the AutoSwitch 2 using the following parameters:

- At a height that places the inlet ports centered approximately 66” from the floor.
- In a position that is convenient for making connections that clear cylinders and other systems in the installation space.
- Using appropriate hardware based on wall construction, anchor mounting tabs to the wall.

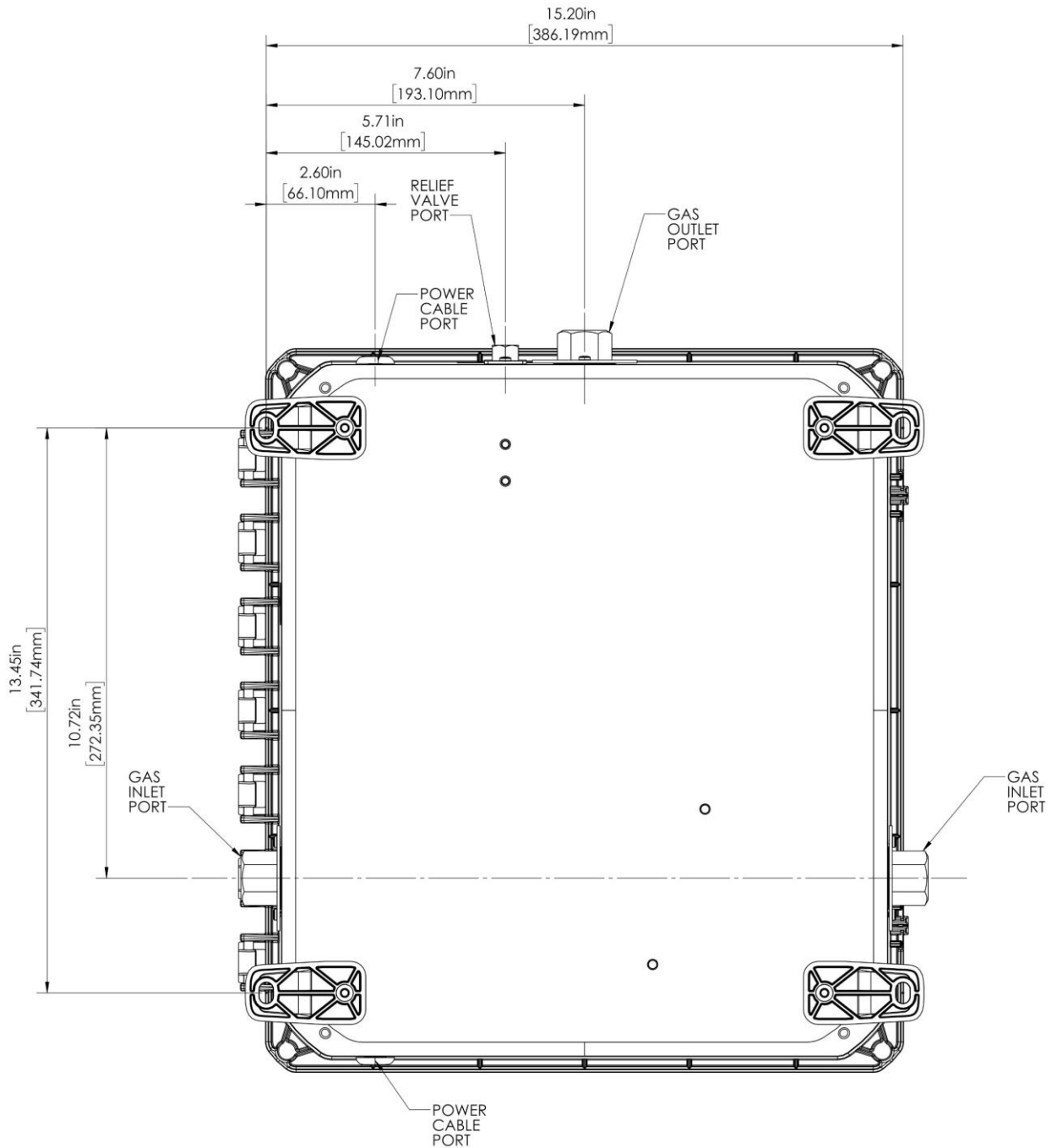

Power Requirement

The AutoSwitch 2 requires an external 24 Volt DC 0.8 Amp power source. CONCOA can provide an optional 24VDC power cable with a transformer for 100-240VAC wall receptacles.

If not using the optional CONCOA power cable and transformer, use the included 0.187" (4.75mm) Quick Connect Female 18-22 AWG Fully Insulated Crimp Connectors provided in the ADI packaging to connect power to the spade terminal connector terminals TM1 for +24V and TM2 for Ground.

Note: There is no ON/OFF power switch for the AutoSwitch 2. The installer must provide any required power switching external to the product.

Installing inlets, outlets, and relief valve vent

The AutoSwitch 2 system has two 1/2" NPT inlet bulkheads, one 1/2" NPT outlet bulkhead, and one 1/4" relief valve vent bulkhead connections. Do NOT allow these to turn when installing fittings.

Double wrench - Use an open-end wrench on the bulkhead and the fitting being installed, not a pipe wrench, to install accessories to the AutoSwitch 2.

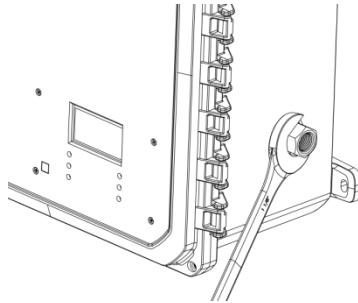

NPT connections require the use of PTFE tape on the threads to make a gas tight seal. On stainless steel connections, the thread sealant helps prevent the connections from galling together when tightening or loosening. CONCOA uses PTFE tape on all of its NPT connections.

NPT taping Instructions:

Inspect the NPT threads and if necessary, clean the fitting to remove any dirt or thread sealant that remains on the threads. Start the PTFE tape on the second thread as shown in figure below; make sure the tape does not overlap the end of the fitting. As the tape is wrapped in the direction of the thread spiral, pull tightly on the end of tape so that the tape conforms to the threads. Wrap the tape around the threads twice. Cut off the excess tape and press the end firmly into the threads.

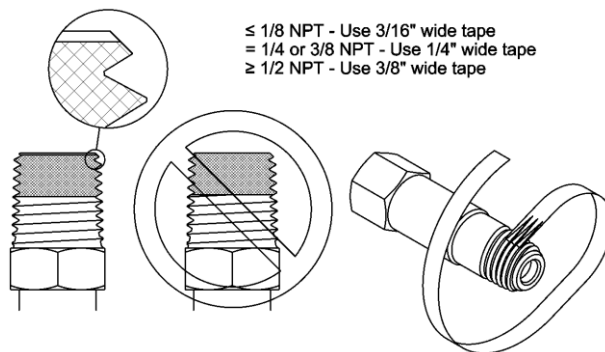

Refer to instructions provided with accessories assembled to the AutoSwitch 2 system for specific instructions for those devices.

Connecting to a Cylinder

1. Before removing the cylinder cap, move the cylinder of gas to the work site:
 - a. Secure cylinder to the floor, wall, or bench with appropriate chain, strap, or stand to prevent toppling.
 - b. Remove the cylinder cap.
 - c. Be sure the cylinder valve is tightly closed (clockwise)
 - d. Remove the cylinder valve plug, if any.
 - e. Inspect the cylinder valve and threads for damage or contamination.

2. Secure the cylinder connection to the cylinder in the following manner:
 - a. Do not force. Tightening the nut onto the cylinder connection should be easy. If it is not, the connection may be wrong for the type of gas being used.
 - b. Left-hand threads are used on some cylinder connections. A notch in the middle of the hex nut typically indicates a left-hand thread.
 - c. Gaskets are used on some inlet connections. Be sure the gasket is in good shape. Do not over-tighten to avoid squashing the gasket into the gas line. Keep extra gaskets on hand.
 - d. Never use oil or grease on regulator or cylinder fittings, as it may contaminate pure gases, or create a fire hazard.

3. **Note:** Before removing the cylinder, close the cylinder valve and associated valves that connect the cylinder to the system. After replacement, open the new cylinder valve and associated valves that connect the cylinder to the system.



Allowing the cylinders to go below minimum pressures can harm the AutoSwitch 2. To improve user awareness, a remote alarm can be used to provide an audible and visual warning that a cylinder needs to be replaced.

Pressurizing the system for the first time

Before system startup, it is recommended that all systems be pressure tested, leak tested, and purged with an inert gas such as nitrogen. Use an adapter if the AutoSwitch 2 did not come with CGA 580 connections. Adaptors are only for system startup or checks and should never be used on a permanent basis.

Startup Procedure:

1. Wear safety glasses and gloves.
2. Be sure that both ends of all hoses are secured before pressurizing.

WARNING

Pressurizing a hose that is not connected on one end can lead to serious injury.

3. When first pressurizing, do not stand in front of or contact the switchover system. Slowly open the cylinder valve. Observe the input pressure reading on the AutoSwitch 2 Screen rise until it reaches full cylinder pressure.
4. Keep the hand wheel or wrench on the open cylinder valve at all times, to allow prompt emergency shut-off.
5. Inspect all connections for leaks and fix any leaks. A leak detection solution may be applied to the connections (if compatible with the application) which indicates leaks by bubbling. To further check for leaks, or if the leak detection solution cannot be used, close the cylinder valve for a period of time (recommended 24 hours), and observe the high pressure displays for a drop in pressure. If so indicated, recheck the CGA connection and all other high-pressure portconnections.

CAUTION

Never attempt to fix a leak under pressure. If leaks are detected, depressurize the system and retighten the connection. Begin again at step 3.

CAUTION

While CONCOA assembles the AutoSwitch 2 system components to exacting leak-tight standards, the customer should also inspect for any loosening of internal parts that may occur in shipping or installation by completing the pressure decay test detailed above. If all external leaks have been found, corrected, and the system still indicates a leak, open the enclosure front cover and check for leaks on the system's fittings as described above.

6. Slowly turn the line regulator set screw clockwise as shown below. This will increase the pressure of the line. Adjust to the desired working pressure and again check for leaks using the methods described above

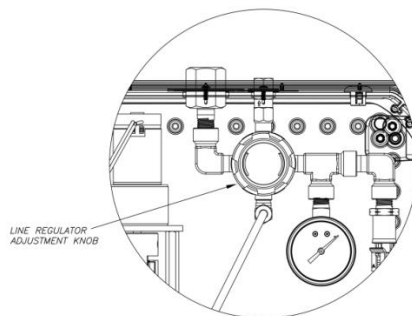

ELECTRONIC OUTPUTS

Connection to Dry Contacts

The AutoSwitch 2 provides four dry-contact relays to indicate alarm conditions for the AutoSwitch 2. These are rated 30 Watts maximum, not to exceed 36 Volts or 1 Amp. There are independent relay signals for Left Inlet Pressure Status, Right Inlet Pressure Status, Outlet Pressure Status, and a Master alarm.

The recommended cable for this assembly is 18-26 AWG wire (Alpha # 1176C or equivalent). An 18 AWG 8 conductor wire is provided with the product. If desired, the ends of the cable can be tinned or crimped into a ferrule sleeve to prevent wire fraying. The length of each cable should be limited to 1500 feet for dry contact relay inputs.

POWER TO AUTOSWITCH 2 MUST BE OFF. Wire common voltage in to the common "COM" terminal block as shown below. Then wire the signal to the normally closed "NC" or normally open "NO" terminal block as shown below.

If using the recommended Normally Open side of the contact then an alarm or a loss of power or an accidentally cut alarm wire will result in an open circuit and all three conditions will look the same to a downstream device.

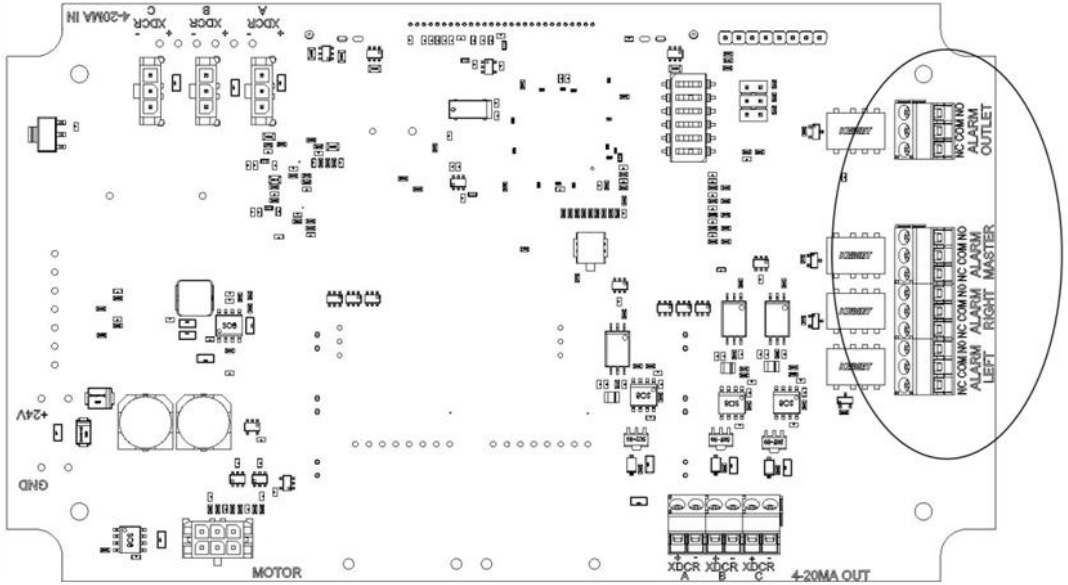

If connecting Left and Right relay outputs to an Altos 2, refer to the Altos 2 manual and the diagram below:

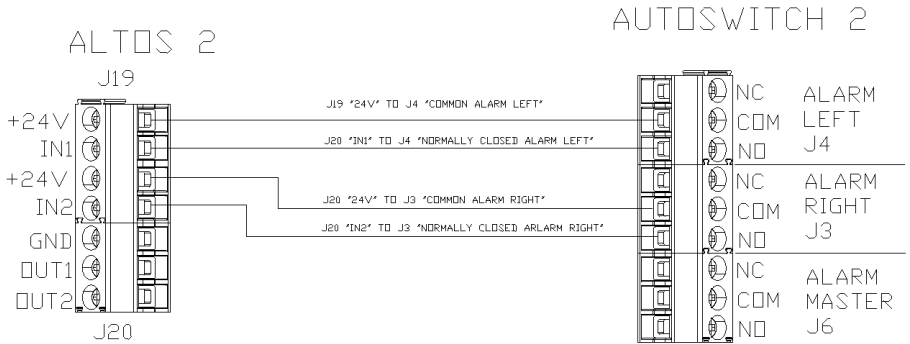

Connection to 4 – 20 mA Transducer Outputs

Three 4-20 mA transducer output circuits are provided to transmit the pressure shown on the front of the AutoSwitch 2 to a remote alarm such as the Altos 2 Remote Alarm. There are independent 4 – 20 mA signals for Left Inlet Pressure, Right Inlet Pressure, and Outlet Pressure. The remote 4-20ma device should provide a 24V feed to the Autoswitch 2 circuit, and the Autoswitch 2 will limit the current returned to the remote device.

The recommended cable for this assembly is 18-26 AWG wire (Alpha # 1176C or equivalent). An 18 AWG 8 conductor wire is provided with the product. If desired, the ends of the cable can be tinned or crimped into a ferrule sleeve to prevent wire fraying. The length of each cable should be limited to 500 feet for 4 – 20 mA output signals.

POWER TO AUTOSWITCH 2 AND REMOTE DEVICE MUST BE OFF. Wire + signal and – signal wire to the terminals shown below from your Altos 2 or other device requiring 4 – 20 mA signals. The remote device or Altos 2 provides 24V power and ground, and the AutoSwitch 2 limits the current through the connection to 4-20mA, just like a transducer would. This current matches the AutoSwitch 2 transducer 4-20mA input current (corrected for the AutoSwitch 2's transducer offset, if any). The Remote device or Altos 2 should be configured with identical scaling as AutoSwitch 2 (6000 PSIG transducers for XDCR A and B, and 1000 PSIG transducer for XDCR C).

Wiring for Altos 2 is shown below. Note: If using an Altos 2 and the AutoSwitch 2, there will likely be a variation of +/- 25 PSIG. The Altos 2 offset can be adjusted slightly to more closely match.

NOTE: The Altos 2 using the 4-20 mA signal from an AutoSwitch 2 will not reflect the REPLACE condition on the AutoSwitch 2. The Altos 2 has its own alarm under value - alarm under value may have to be set higher to properly signal a switchover to accommodate variation. If the Altos 2 is required to reflect the state of the AutoSwitch 2 – use the Connection to dry contacts instead.

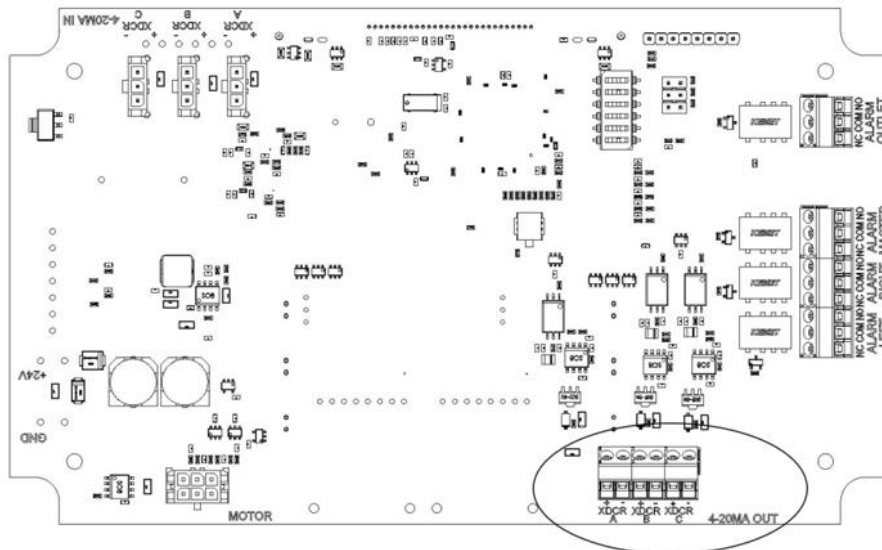

If connecting Left and Right 4 – 20 mA transducer outputs to an Altos 2, refer to the Altos 2 manual and the diagram to the right:

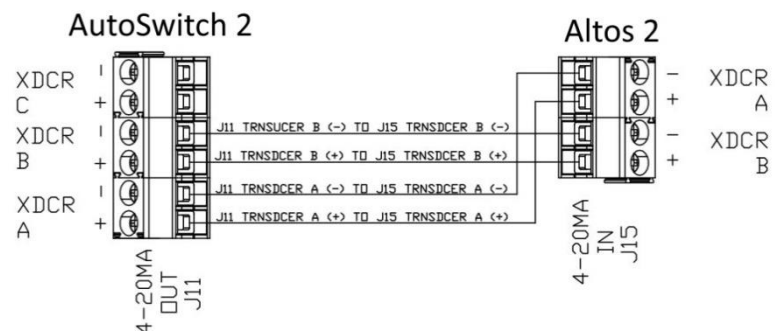

Security (Keypad) Lockout Instructions

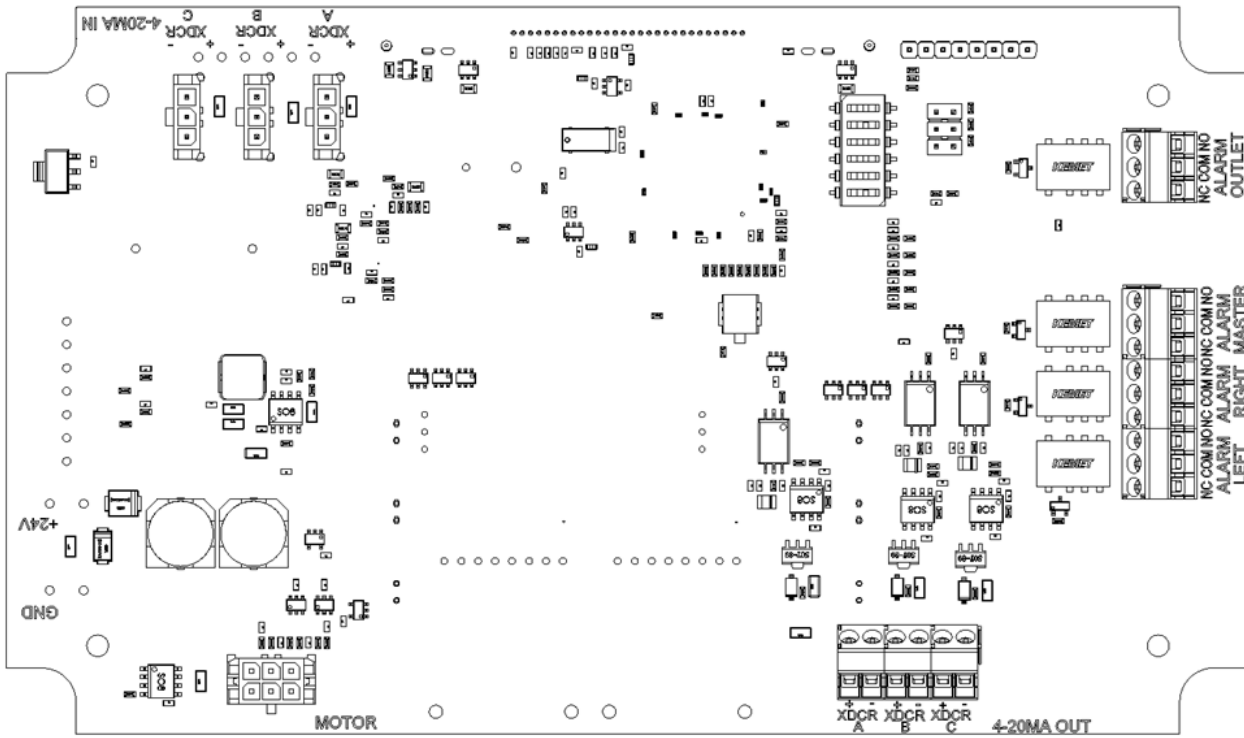

Security (Keypad) Lockout

The keypad can be modified using the internal dip switch SW5-2.

When "ON" – Keypad will accept user input

When "OFF" – Keypad will be disabled

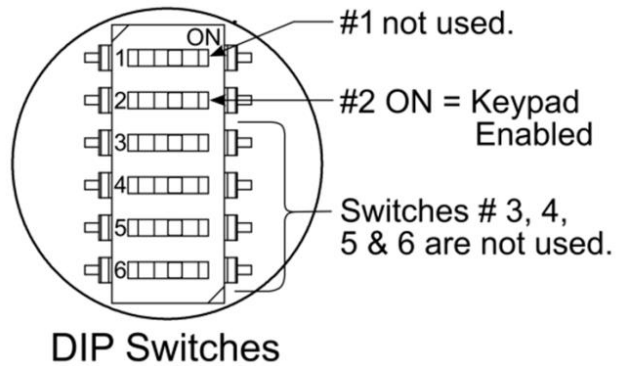

USER INTERFACE

Graphical Status Display and User Interface

The AutoSwitch 2 contains a built in graphical status display and user interface. The status display clearly shows the current state of the automatic switchover system. The front cover conveys overall system status and a user interface for navigating the menus and for requesting a bank select.

Menu Navigation buttons

- Up
- Left/Right
- Down

Bank Select Button



LCD status

In use:

- Steady Green: Side is in use
- Blinking Green: performing bank select

Cylinder Status

- Green Ready: side has pressure
- Red Replace: side is empty

LCD Status

AutoSwitch 2's LCD displays system status and configuration of the system. The default screen displays after power-up. Many screens have a timeout, and revert to this screen after a short timeout.

Outlet Pressure

Operating Mode

- Auto or
- PRI/RESV

Left user selected replace pressure

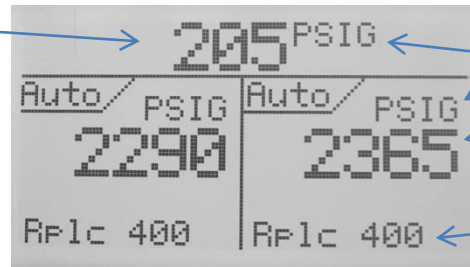

Selected Units of Measure

Left and Right Inlet Pressures

Right user selected replace pressure

In the event of a major error, the LCD Main Screen will turn red and display the highest priority notification status. If in this state, the unit needs maintenance before normal operations can resume.

Navigation

A menu button press will display the top level Settings menu. The navigation menu buttons have the following uses:

- **Up** or **Down** moves up and down the menus items.
- **Right** selects a menu item.
- **Left** goes back to the previous menu.

Some menus allow for setting values. For these menus the system will display maximum and minimum allowable values near the top of the screen, and the currently selected value at the bottom. To change the current value the buttons below will perform the following on the digit being highlighted with a carrot "∧":

- **Up** or **Down** increases or decreases the value. Increasing a digit from 9 wraps back to 0 and vice versa.
- **Right** moves to the next digit to the right. If already at the far right digit, then **Right** will accept the new value.

- **Left** moves to the next digit to the left. If already at the far left digit, then **Left** goes back to the previous menu and any value changes are ignored.

Settings Menu

From the main screen, pressing a menu button activates the main menu.



1. Changes operational replace set point and units of measure.
2. Changes operational replace set point and units of measure.
3. Sets outlet's hi and low alarm set points and units of measure.
4. Status List shows a list of all notification status events. If items are flashing on the LCD or the LCD is red, check this menu item.
5. To clear notification statuses that are latched, select the Reboot option.
6. System menu provides access to configuration parameters.

Left Inlet & Right Inlet

Use the **Up** & **Down** buttons to highlight the desired item, and **Right** button to select.

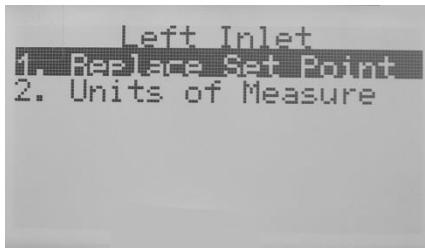

1. To see/set the replace pressure set point. Also shown on the main status screen.
2. To see/change the selected inlet's unit of measure. Note that each input can have a different unit of measure.

Selecting 1 above yields:

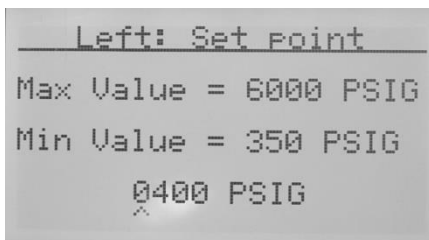

Max and Min values provide the limits for the replace set point. Press **Right** & **Left** to move between digits. Use **Up** & **Down** buttons to change the current value. When on the far right digit, **Right** accepts the new setting.

Selecting 2 above yields:

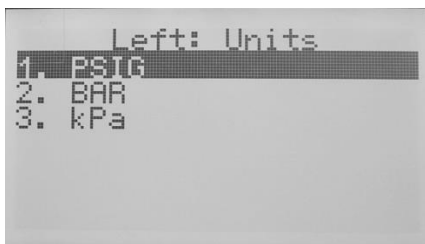

Use **Up** & **Down** buttons to highlight the desired units of measure. Press **Right** to accept the highlighted unit of measure.

Outlet

Use the **Up & Down** buttons to highlight the desired item, and **Right** button to select.

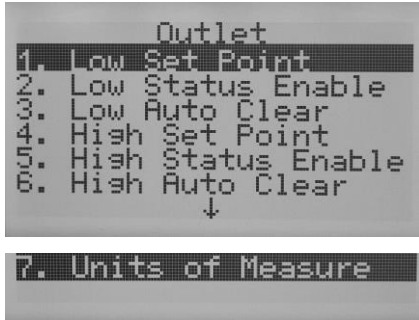

1. To see/set the low pressure set point.
2. To enable/disable the Low Set Point event
3. To Auto Clear the Low Set Point event, or not to latch the event.
4. To see/set the high pressure set point.
5. To enable/disable the High Set Point event
6. To Auto Clear the High Set Point event, or not to latch the event.
7. To see/change the outlet's unit of measure.

The resulting three screens work just like the Inlet screens above.

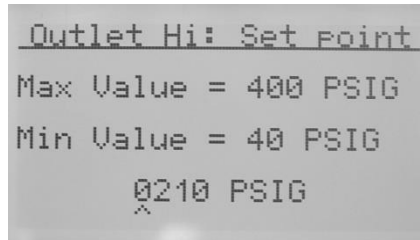
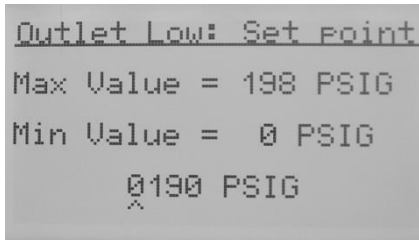

The system optionally supports an **Outlet Over Pressure** or **Outlet Under Pressure** status, which is disabled by default. If the respective set point is reached, the Outlet pressure on the main status screen will flash and the words “Over” or “Under” are displayed next to the outlet pressure. By default these two events are configured as Auto Cleared. If not configured as Auto Cleared then these statuses will be “Latched” which could aid in system maintenance and will remain active even after the over/under condition goes away. Once the condition has gone away, choose the Reboot-Clr Stats menu to clear any latched notification events. For the Status Enable and Auto Clear choices, a simple enable/disable screen is provided.



1. Disables the feature
2. Enables the feature

Status List

The system displays any notification statuses it detects on this screen. The Troubleshooting section shows a detailed explanation of all events and how to correct them.



This example shows a right low pressure event, indicating the right cylinder needs replacement. If multiple status events are shown, the up/down buttons can scroll through them.

MAINTENANCE

On regular intervals, the system should be checked for leaks and proper function (see troubleshooting). Any leaks in the system should be corrected immediately. The hose check valve should also be checked for leaks when a depleted cylinder is removed.

NOTE: The system inlet and hose should be pressurized when checking for leaks. At no time should the preset regulator's or priority valve regulator's pressure settings be changed.

TROUBLESHOOTING

General Troubleshooting

Symptom	Cause
<ol style="list-style-type: none"> Gas leakage at the line regulator outlet when the adjusting knob of the line regulator is completely backed out. With no flow through the system (downstream valves closed and adjusting screw in) line pressure steadily increases above set pressure. Gas leakage from spring case (adjusting screw/knob end of regulator). Gas leakage from any joint. Excessive drop in working pressure with regulator flowing gas. Gas leakage from relief valve. Gas leakage from internal outlet gauge Internal outlet gauge does not return to zero when not under gas pressure Internal outlet gauge does not consistently repeat the same reading. 	<ol style="list-style-type: none"> Internal outlet gauge has malfunctioned. Replace or repair. Regulator(s) have malfunctioned. Replace or repair.
<ol style="list-style-type: none"> Switchover system seems to be using gas from the primary and reserve cylinders (pressure is decreasing on both inlet displays at the same time) 	<ol style="list-style-type: none"> Observe the inlet pressure. It may be necessary to do this during times of the heaviest use. If either inlet pressure is less than the Minimum Inlet Pressure shown in the model table above, replace the high-pressure cylinders.
<ol style="list-style-type: none"> Inlet transducers not reading pressure 	<ol style="list-style-type: none"> Check that the valves on the cylinders are opened. If using a manifold system, check that the valve on the manifold is opened.
<ol style="list-style-type: none"> Remote alarm status lights are not lit 	<ol style="list-style-type: none"> Check that remote alarm is properly wired into the AutoSwitch 2 and the alarm. Check that the remote alarm is powered on. Check settings for "alarm under" in Altos 2 alarm if connected to 4-20mA
<ol style="list-style-type: none"> Remote green status light(s) are lit when the pressure is below the set point on the AutoSwitch 2 inlets (Dry contact relay connections only) Remote red status light(s) are lit when the pressure is above the set point on the AutoSwitch 2 inlets (Dry contact relay connections only) 	<ol style="list-style-type: none"> Cable to remote alarm wired incorrectly. Follow instructions in remote alarm Instruction Manual to correct problem. Remote alarm configured incorrectly. Review manual for remote alarm.

Symptom	Cause
1. With full tank pressure, red alarm light(s) are on.	<ol style="list-style-type: none">1. Cable to remote alarm wired incorrectly. Follow instructions in remote alarm Instruction Manual to correct problem.2. Remote alarm configured incorrectly. Review manual for remote alarm.

SERVICE

CUSTOMER ASSISTANCE

A unit that is not functioning properly should not be used and should be serviced. For service, contact your local distributor or CONCOA Customer Service at 1-800-225-0473. Prior to calling please fill out the below worksheet and be prepared to provide it. A Return Material Authorization (RMA) number must be issued for any product returned to CONCOA for service.

Service Worksheet

Parameter	Customer Unit Details
Model Number	
Serial Number	
Left Inlet Pressure	
Left Replace Set Point	
Right Inlet Pressure	
Right Replace Set Point	
Outlet Pressure	
Flow rate	
Gas Service	
Environmental Conditions	

Shipping

When shipping product back to CONCOA for repair the following steps should be followed:

1. Package the product sufficiently to prevent damage. If possible return product in its original packaging.
2. Include RMA number on the outside of the carton.
3. Ship prepaid.
4. Include a written description of the problem you encountered with the product inside the package.
5. Include a statement of the gas service the product was used in.
6. Purge all equipment before shipping to protect the transporter and service personnel. Purging is especially important if the equipment has been in hazardous or corrosive gas service.

ADVANCED SETTINGS

System/Service Menus

Use the **Up & Down** buttons to navigate through the options. Use the **Right** button to enter sub-menu. Use the **Left** button to go back.



1. Switches between Auto and Primary/Reserve modes
2. Should match the left transducer maximum 20ma rating.
3. Should match the right transducer maximum 20ma rating.
4. Should match the outlet transducer maximum 20ma rating.
5. An offset can be entered to correct for sensor drift.
6. An offset can be entered to correct for sensor drift.

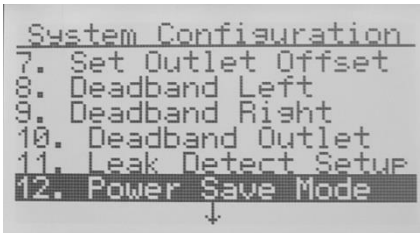

7. An offset can be entered to correct for sensor drift.
8. A hysteresis value for the **Left Replace** pressure.
9. A hysteresis value for the **Right Replace** pressure.
10. A hysteresis value for the **Outlet Over/Under Pressure**.
11. Configure leak detect settings
12. For LCD screen blanking.

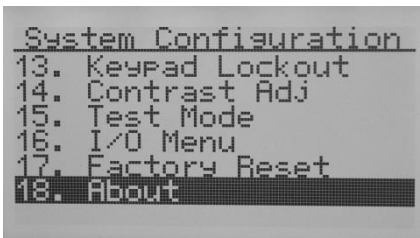

13. Instructions for locking out the keypad.
14. Setting the LCD screen contrast
15. Exercise all relays/LEDs/LCD bits.
16. Detailed Input/Output status.
17. Factory Reset system to factory defaults
18. About details including software version

Switchover Mode

Use the **Up & Down** buttons to navigate through the options. Use the **Right** button to activate desired option.



1. Select left side as Primary (and right as Reserve)
2. Select Auto mode. Note this is the only mode where the Bank Select button affects the system.

Left/Right/Outlet Max

This menu configures the software to properly scale the transducer readings. If a different pressure transducer is put in the system, this setting must change to match the new transducer reading at full scale (20 mA). Left and right transducers default to 6000 PSIG, outlet to 1000 PSIG

```
Left: Max Pressure
Max Value = 6000 PSIG
Min Value = 15 PSIG
      6000 PSIG
      ^
```

Max and Min values provide the limits for the transducer.

Press **Right & Left** to move between digits.

Use **Up & Down** buttons to change the current value.

When on the far right digit, **Right** accepts the new setting.

Left/Right/Outlet Offset

This configuration item allows an offset to be applied to the transducer reading. This could be useful in case of sensor drift. To use this menu:

- You can either depressurize the system (so all three transducers have a known 0 PSIG), or apply a known pressure to the inlet transducers, or a known pressure to the outlet.
- Enter the “Set Left/Right/Outlet Max” menu.
- Use the menu keys to enter the known/calibrated pressure
- Press the Right menu button repeatedly till the new value is saved.

For example, if the inlet has 2200 PSIG applied to the inlet (verified by a calibrated pressure gauge), but the AutoSwitch 2 is showing 2050 PSIG on the main screen, then go into this menu and enter 2200. The system will capture the 150 PSIG difference between its current reading vs. what you told it the value should be. Once set, the main screen should now show 2200 PSIG, and the offset menu will display the calculated difference (150 PSIG) it captured.

To clear offsets, use the “Reset” menu to put all parameters back to factory defaults.

```
Left: Offset
Max Value = 6000 PSIG
Min Value = 0 PSIG
      0000 PSIG
      ^
```

Max and Min values provide the offset limits.

Press **Right & Left** to move between digits.

Use **Up & Down** buttons to change the current value.

When on the far right digit, **Right** accepts the new setting.

Left/Right/Outlet DeadBand

The deadband setting is a hysteresis value to prevent a status event from dithering on/off if the monitored value is right on the event threshold. For example, if the input replace set point is set to 700 PSIG, and the deadband is set to 60 PSIG, then the replace event will occur as the pressure drops below 700 PSIG. The event will not clear until the pressure goes above 760 PSIG.

```
Left: Deadband
-----
Max Value = 600 PSIG
Min Value = 60 PSIG
      0060 PSIG
      ^
```

Max and Min values provide the offset limits.

Press **Right & Left** to move between digits.

Use **Up & Down** buttons to change the current value.

When on the far right digit, **Right** accepts the new setting.

Leak Detect

Leak detection provides a configurable mechanism to monitor for inlet leaks. The assumption is that the side that is not active should maintain a constant pressure; how constant depends on system installation and many variables, most notably cylinder temperature. The system provides two parameters to configure leak detection for each side.

1. Left/Right Min to Chk: The duration in minutes to check for the pressure drop (4 to 5000 minutes).
2. Left/Right SetPnt: The amount of pressure drop that should be considered a leak (6 to 6000 PSIG).

The system does some averaging of pressure changes over the configured duration in order to help prevent false status events. For example if the entered duration is 40 minutes, and the entered pressure drop is 200 PSIG, then the system would be looking for a 200PSIG/40minutes drop, or 5PSIG/minute on average over the course of any given 45 minute window.

These two parameters allow for ignoring expected pressure change, and triggering when pressure changes exceed the norm. Leak Detect is off by default.

The Leak Detect menu provides these options:

Left Detect	Configures whether the event monitoring is on or off for the respective side.
Right Detect	Configures whether the event monitoring is on or off for the respective side.
Left Min to Chk	Selects how many minutes window to check for given pressure drop
Right Min to Chk	Selects how many minutes window to check for given pressure drop
Left SetPnt	The amount of pressure drop that should be considered a leak.
Right SetPnt	The amount of pressure drop that should be considered a leak.

Power Save Mode

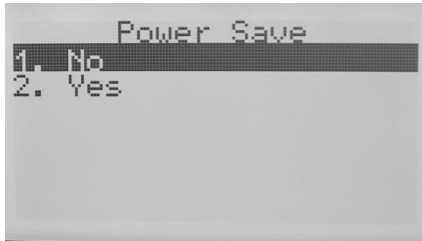

Power Save Mode, when enabled, turns off the LCD screen after fifteen minutes of inactivity (when the screen is off, the unit will still function as normal). Pressing any button on the front cover will wake up the LCD screen. Default mode is OFF

Keypad Lockout

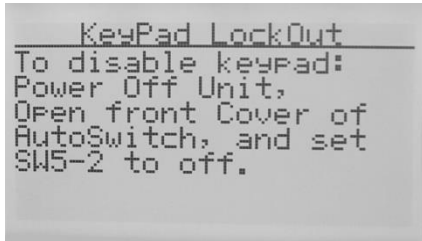

Keypad Lockout provides instructions for changing the Keypad Lockout mode. Default mode is OFF.

Contrast Adj

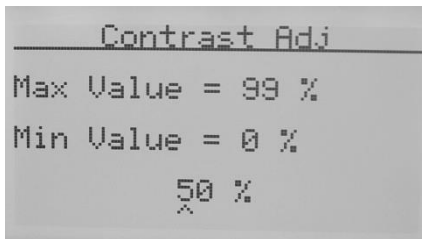

Contrast adjustment allows the screen contrast to be adjusted. Pressing the up or down buttons will increase or decrease the contrast ratio of the screen. The default factory value is 50. The value can be adjusted between 0 (the lightest) and 99 (the darkest). To save the selected ratio, press the right button.

I/O Menu

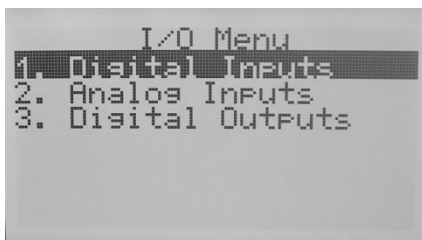

Detailed status for the Inputs and Outputs are available under each option.

DIGITAL INPUTS / LIMIT SWITCHES

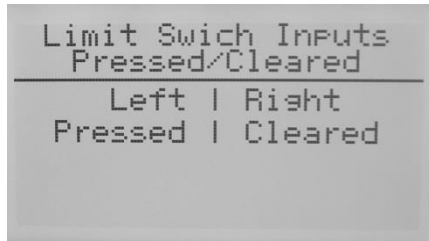

Digital Inputs lists the status of each of the motor limit switches, and shows if they are open or closed. This screen would help show the cause of a “Miswire” fault. Only one switch should be pressed at any given time, unless the unit is in the middle of a bank-select, in which case neither switch should be pressed.

ANALOG INPUTS

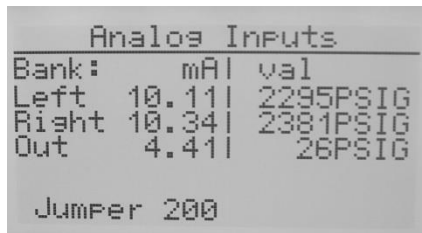

The status of the 4-20ma transducer inputs and the model select jumper are displayed on this screen. For the 4-20ma inputs, the display shows the electrical current in milliamps as well as the corresponding pressure in PSIG. A “-Lo-” means the current is less than 3.7ma and is too low to measure. A “-Hi-” means the current is greater than 20.4 ma and is too high to measure. These out of range readings will induce a “Transducer Error” status event. The jumper setting is also an analog input the unit decodes and displays here as 100, 200, or 350 PSIG models. A missing jumper will default to 350 PSIG model (and induce an “Invalid Jumper” status event).

DIGITAL OUTPUTS



The unit displays all the digital outputs on this screen. Press the **Down** button to see additional outputs. A non-functional output can be checked here. For example, if the left relay should be active but is not closing its contact as expected, this screen will confirm if the system is trying to activate the contact (implying a bad relay) or not (something else is preventing the system from activating the relay like a higher priority status event).

Factory Reset

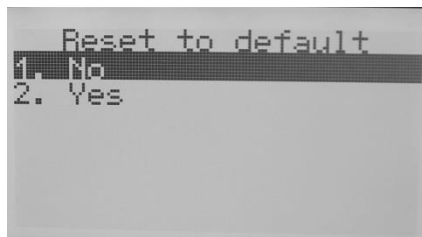

Activating Factory Reset restores all parameters to the factory default state and reboots the device.

About



The about screen displays the system part number as well as the installed software version.

Status Event Messages

Status Event messages on the screen provide troubleshooting aids as described below. The effect a status event has on the system relays are noted for each status listed.

Status	Description	Out Rly	Left Rly	Right Rly	Mstr Rly	Possible Solution
Up Button Stuck	Up button is stuck				X	<ul style="list-style-type: none"> Case rubbing against button Failed button
Down Button Stuck	Down button is stuck				X	<ul style="list-style-type: none"> Case rubbing against button Failed button
Left Button Stuck	Left button is stuck				X	<ul style="list-style-type: none"> Case rubbing against button Failed button
Right Button Stuck	Right button is stuck				X	<ul style="list-style-type: none"> Case rubbing against button Failed button
Bank Button Stuck	Bank Select button is stuck				X	<ul style="list-style-type: none"> Case rubbing against button Failed button
Right Leak Detection	Right / Left Side Leak Detected				X	<ul style="list-style-type: none"> Check for leaks
Left Leak Detection	Right / Left Side Leak Detected				X	<ul style="list-style-type: none"> Check for leaks
Right Replace	Input Under Pressure, below user set point			X	X	<ul style="list-style-type: none"> Replace right cylinder
Left Replace	Input Under Pressure, below user set point		X		X	<ul style="list-style-type: none"> Replace left cylinder
Outlet Over Pressure	Outlet over user set point	X			X	<ul style="list-style-type: none"> Outlet regulator set too high Bad outlet regulator Infrastructure induced spike in pressure.
Outlet Under Pressure	Outlet under user set point	X			X	<ul style="list-style-type: none"> Outlet regulator set too low. Demand exceeds regulator capacity. Bad outlet regulator
Missing Jumper	Missing Jumper				X	<ul style="list-style-type: none"> Jumper missing on PCB J21
Invalid Jumper	Jumper read invalid value				X	<ul style="list-style-type: none"> Possible short inside AutoSwitch 2. Replace PCB.

Status	Description	Out Rly	Left Rly	Right Rly	Mstr Rly	Possible Solution
Right Transducer Err	Bad transducer reading (outside 4-20ma)				X	<ul style="list-style-type: none"> • Check wiring to transducer • Replace transducer
Left Transducer Err	Bad transducer reading (outside 4-20ma)				X	<ul style="list-style-type: none"> • Check wiring to transducer • Replace transducer
Out Transducer Err	Bad transducer reading (outside 4-20ma)	X			X	<ul style="list-style-type: none"> • Check wiring to transducer • Replace transducer
Motor/Switch Miswire	Motor/Switch Miswire. Caused by: *Motor Polarity Reversed *Motor Limit Switches swapped				X	<ul style="list-style-type: none"> • Contact Service
Motor/Switch Failure	Motor Limit Switch failure: * Upper limit switch fault * lower limit switch fault * motor event time exceeded				X	<ul style="list-style-type: none"> • Contact Service

WARRANTY INFORMATION

This equipment is sold by CONTROLS CORPORATION OF AMERICA under the warranties set forth in the following paragraphs. Such warranties are extended only with respect to the purchase of this equipment directly from CONTROLS CORPORATION OF AMERICA or its Authorized Distributors as new merchandise and are extended to the first Buyer thereof other than for the purpose of resale.

For a period of one (1) year from the date of original delivery (90 days in corrosive service) to Buyer or to Buyer's order, this equipment is warranted to be free from functional defects in materials and workmanship and to conform to the description of this equipment contained in this manual and any accompanying labels and/or inserts, provided that the same is properly operated under conditions of normal use and that regular periodic maintenance and service is performed or replacements made in accordance with the instructions provided. The foregoing warranties shall not apply if the equipment has been repaired: other than by CONTROLS CORPORATION OF AMERICA or a designated service facility in accordance with written instructions provided by CONTROLS CORPORATION OF AMERICA; or altered by anyone other than CONTROLS CORPORATION OF AMERICA; or if the equipment has been operated under improper conditions or outside published specifications; or if the equipment has been damaged or does not function due to improper installation, improper supply of required utilities, accident, abuse, misuse, natural disaster, insufficient or excessive electrical supply, abnormal mechanical or environmental conditions, or debris or particles in the gas or liquid source of supply.

CONTROLS CORPORATION OF AMERICA's sole and exclusive obligation and Buyer's sole and exclusive remedy under the above warranties is limited to repairing using new or reconditioned parts or replacing, free of charge except for labor if permanently installed for the continuous supply of gas by other than a technician certified by CONTROLS CORPORATION OF AMERICA specifically to do so, at CONTROLS CORPORATION OF AMERICA's option, the equipment or part, which is either (1) reported to its Authorized Distributor from whom purchased, and which if so advised, is returned with a statement of the observed deficiency, and proof of purchase of equipment or part not later than seven (7) days after the expiration date of the applicable warranty, to the nearest designated service facility during normal business hours, transportation charges prepaid, and which upon examination, is found not to comply with the above warranties with return trip transportation charges for the equipment or part paid by Buyer or (2) in the case of designated equipment permanently installed for the continuous supply of gas, reported to an Authorized Service Center with proof of initial installation no later than seven (7) days after the expiration date of the applicable warranty, and which is evaluated for compliance with the above warranties by technician certified by CONTROLS CORPORATION OF AMERICA, and which is determined by CONTROLS CORPORATION OF AMERICA based on said evaluation to be non-compliant.

CONTROLS CORPORATION OF AMERICA SHALL NOT BE OTHERWISE LIABLE FOR ANY DAMAGES INCLUDING BUT NOT LIMITED TO: INCIDENTAL DAMAGES, CONSEQUENTIAL DAMAGES, OR SPECIAL DAMAGES, WHETHER SUCH DAMAGES RESULT FROM NEGLIGENCE, BREACH OF WARRANTY OR OTHERWISE.

THERE ARE NO EXPRESS OR IMPLIED WARRANTIES WHICH EXTEND BEYOND THE WARRANTIES HEREINABOVE SET FORTH. CONTROLS CORPORATION OF AMERICA MAKES NO WARRANTY OF MERCHANTABILITY OR FITNESS FOR A PARTICULAR PURPOSE WITH RESPECT TO THE EQUIPMENT OR PARTS THEREOF.



Certified ISO 9001

Instruction 3240C

Controls Corporation of America
1501 Harpers Road Virginia Beach, VA 23454
To Order Call 1-800-225-0473 or 757-422-8330 • Fax 757-422-3125
www.concoa.com