

GENERAL ARRANGEMENT

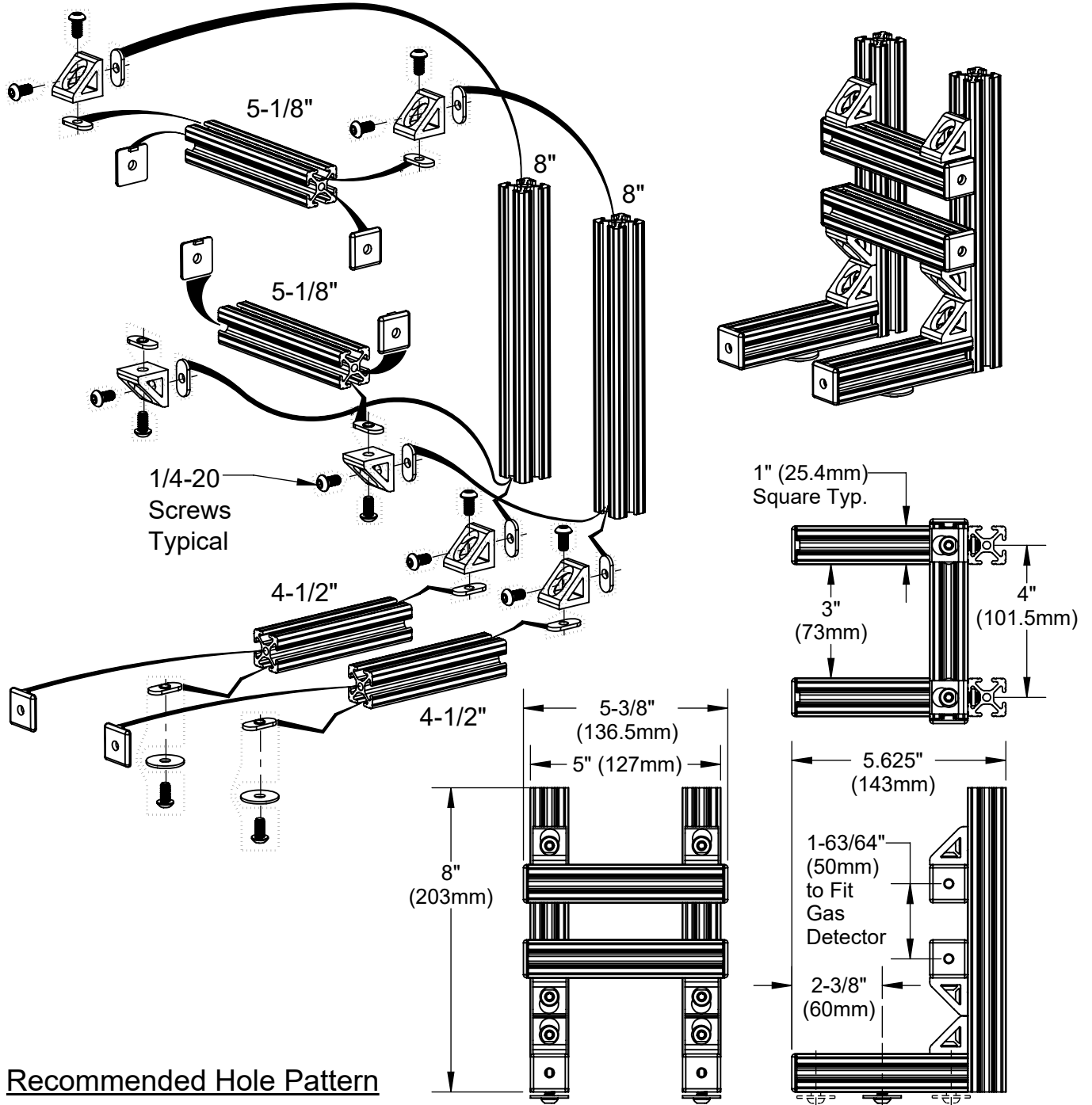

Recommended Hole Pattern

Scale 1:1

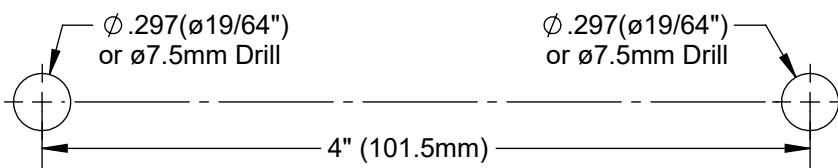

OPEN BACK OF GAS DETECTOR & REMOVE HEX CAP STRAIN RELIEF.

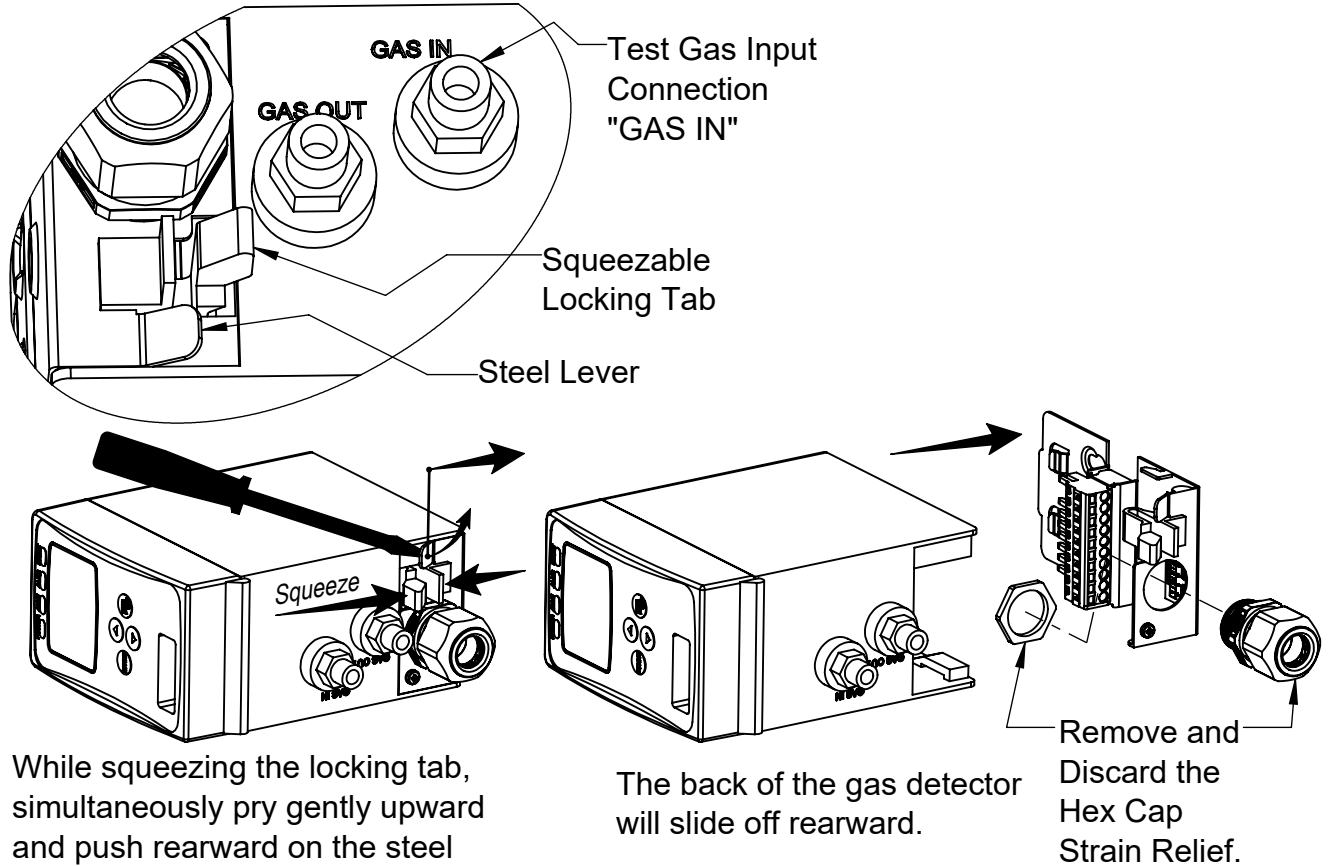

While squeezing the locking tab, simultaneously pry gently upward and push rearward on the steel lever using a medium to large flat head screwdriver.

The back of the gas detector will slide off rearward.

Remove and Discard the Hex Cap Strain Relief.

INSTALL NEW HOLE PLUG CONNECT WIRING

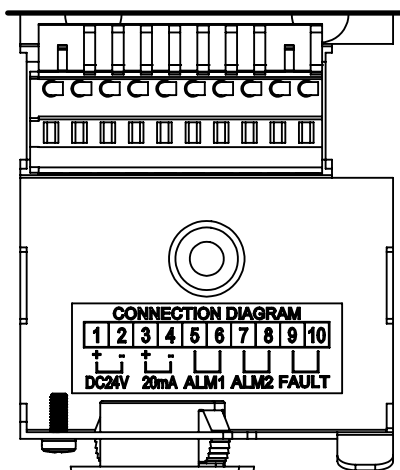

Install Piercable Membrane Hole Plug

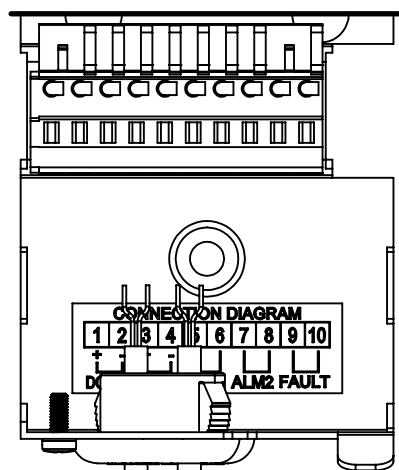

"PWR" Cable

"SIGNAL" Cable

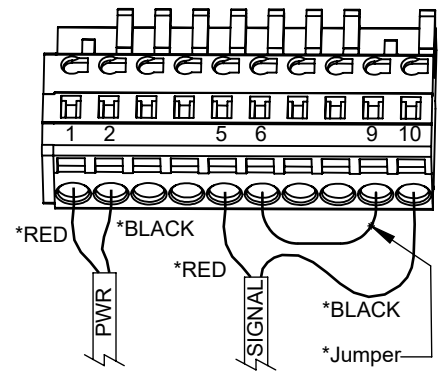

*CONCOA supplied wiring uses 22 AWG conductors.

Poke a Hole in Membrane for Each Cable, and Push the Cables Through

MOUNT THE GAS DETECTOR TO THE BRACKET

