



5805001-01-1 Loss-of-Ventilation Detector Kit Installation Instructions

www.concoa.com

1-800-225-0473

The Loss-of-Ventilation Detector Kit #5805001-01-1 includes a differential pressure switch that can detect a pressure difference of up to 0.50 inches of water (0.018 PSIG) between the low pressure air flowing inside a duct toward a fan or blower and the higher pressure of the atmosphere outside the duct.

SPECIFICATIONS	
Accuracy	±2% of Full Scale
Pressure Limits	-20 Inches Hg to 25 PSIG
Temperature Limits	20°F to 120°F (-6.67°C to 48.9°C)
Power Requirements	24 VDC Regulated ±10%
Switch Type	SPDT (can be set for either Normally Open or Normally Closed operation)
Pressure Connections	1/8" NPT Female Ports
Mounting Requirements	Must be mounted in the vertical position.

The Loss-of-Ventilation Detector Kit #5805001-01-1 is provided set-up for use with the CONCOA #5851008-01-000 Emergency Shutoff Controller. The supplied cable assembly is configured for "Normally Open" operation as required by this device.

- This means:
- a) When no vacuum is detected (the normal condition for the differential pressure switch), the switch is open and current can't flow through the switch and back to the ESO controller.
 - b) When sufficient vacuum is detected as measured between the high and low set points of the pressure differential switch (ventilation has not been lost), the switch closes, and current flows through the switch and back to the ESO controller.
 - c) The ESO controller alarms when current stops flowing because the detected vacuum falls below the low set point on the pressure differential switch (ventilation has been lost).

The differential pressure switch is provided installed in a bracket for mounting the unit vertically on a flat surface, with a $\varnothing 1/8"$ hose barb swivel elbow installed in the side low pressure port of the differential pressure switch, and with the parts shown below for attachment to a gas cabinet and hookup to an existing exhaust duct:

PARTS AND ASSEMBLIES INCLUDED IN THIS KIT:

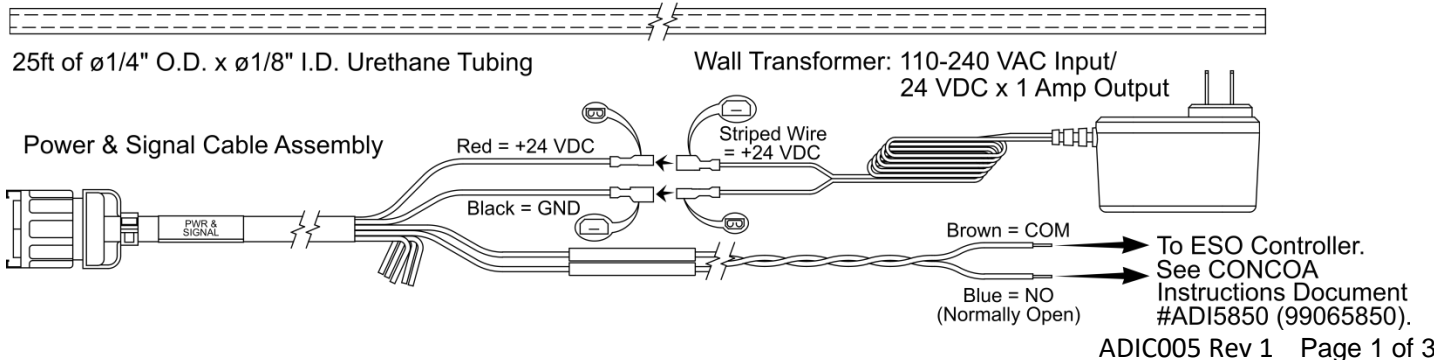
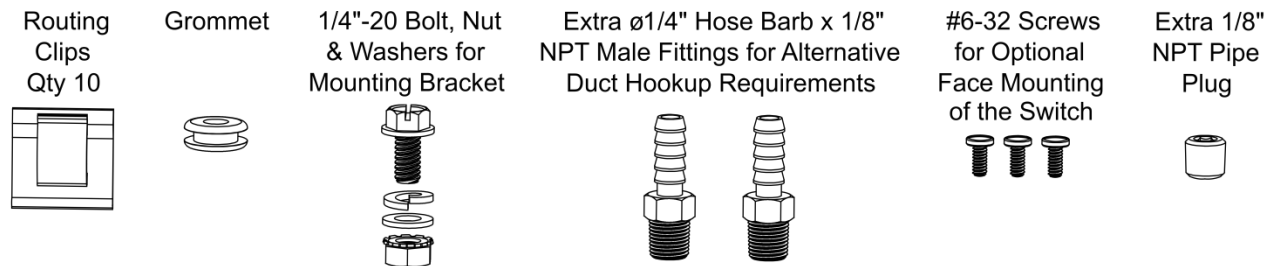

CABLE ASSEMBLY PIN ASSIGNMENTS		
PIN NO.	FUNCTION	WIRE COLOR
A	+ PWR Supply	Red
E	- PWR Supply	Black
C	Low Set Point COM	Brown
B	Low Set Point NC	Violet
D	Low Set Point NO	Blue
H	High Set Point COM	Green
J	High Set Point NC	White
F	High Set Point NO	Orange
K	Not Used	Yellow

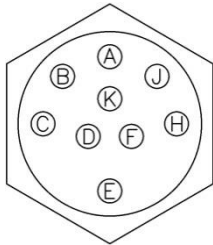

Looking at Connector On Back of Differential Pressure Switch (Appears mirror image on the connector on the cable assembly)

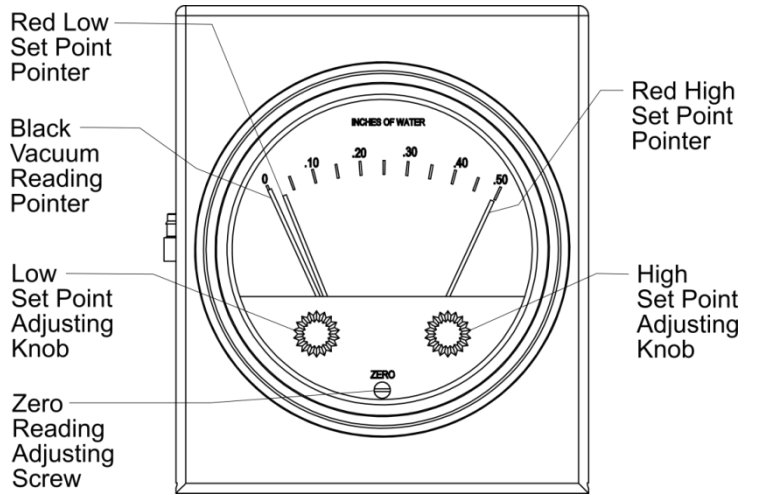

INSTALLATION:

As Illustrated:

- Bolt the pressure differential switch bracket to a flat, level surface (e.g., the top of a gas cabinet).
- Press one end of the urethane tubing onto the hose barb on the pressure differential switch.
- Using the routing clips, route the urethane tubing to a location on the duct where straight flow occurs for at least 8x the duct diameter.
- Drill a $\varnothing 7/16"$ hole in the duct on the low pressure side of the fan, and de-burr the cut edges inside and outside the hole using a de-burring tool.
- Press the grommet into the hole in the duct, and slide the other end of the urethane tubing through the grommet into the duct $1/4"$ to $1"$ deep.

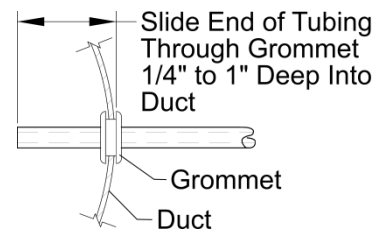
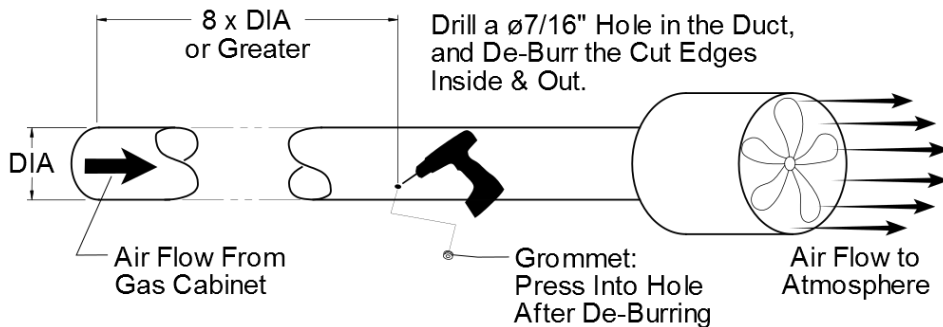
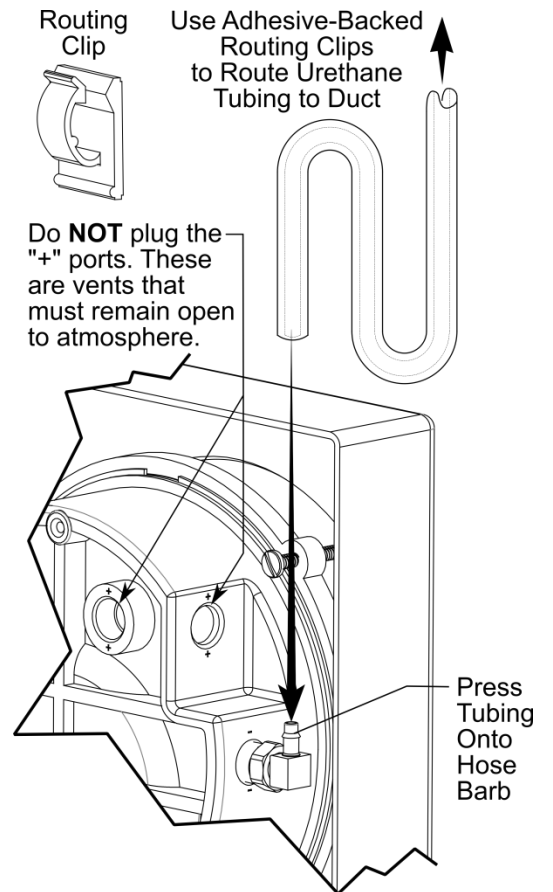
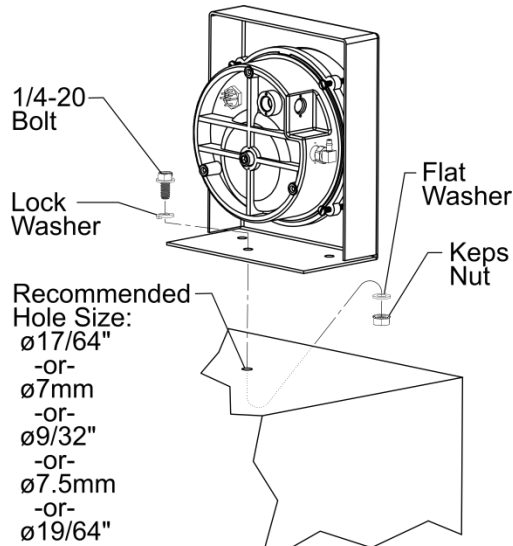

ELECTRICAL HOOKUP:

Supply 24 VDC to the differential pressure switch through the supplied cable assembly. This can be accomplished using the supplied wall transformer. For connecting the cable assembly to the CONCOA Emergency Shutdown Controller, refer to the CONCOA instructions document for the ESO Controller which is available on the company web site www.concoa.com (document #ADI5850, CONCOA part no. 99065850).

SETTING THE PRESSURE DIFFERENTIAL SWITCH:

It is the user's responsibility to determine an appropriate low set point for the pressure differential switch for the user's installation. The high set point is not used. The unit is provided with the high set point set to the maximum position (0.50 inches of water). The position of the high set point pointer has no effect as-provided.

Refer to the steps and illustrations below for recommended differential pressure switch setting instructions.

- 1) With the differential pressure switch mounted on a flat, level surface, adjust the zero screw until the black pointer is aligned with the zero tick mark.

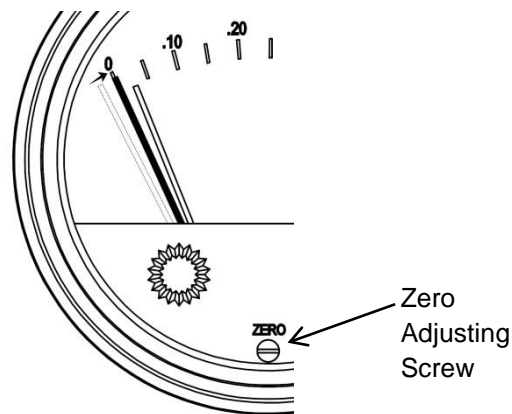

- 2) Supply 24 VDC to the pressure differential switch, and connect the urethane tubing to the switch and to the exhaust duct as described above.

- 3) Turn on the exhaust fan, and observe the vacuum reading on the differential pressure switch.

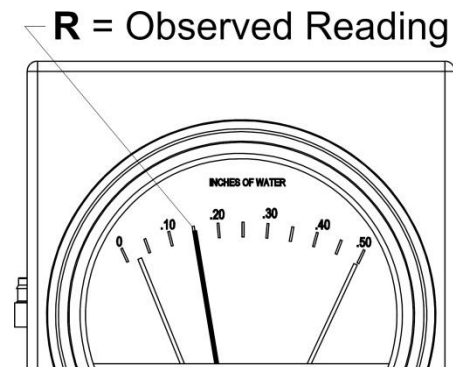

- 4) Dial the low set point pointer to "0", and then dial it back up to approximately half the observed vacuum reading.

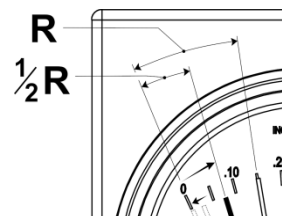

The differential pressure switch is now ready to use with the CONCOA Emergency Shutoff Controller.