

212 SERIES

The 212 Series regulators are intended for primary pressure control of non-corrosive, high purity or liquefied gases (up to grade 4.5) for applications requiring constant pressure control and delivery regardless of supply pressure variations.

- Dual Stage
- Chrome-Plated Forged Brass Body
- 316L Stainless Steel Diaphragm
- Five Port Configuration



212 2331-580 shown

Typical Applications

Argon
Nitrogen
Oxygen
Carbon dioxide
Hydrogen
Non corrosive mixtures

Features

- CAPSULE® Seat**
Increased serviceability and life
- 316L Stainless Steel Diaphragm**
No inboard diffusion
- Forged Body**
Durable, long-lasting construction
- Field-Adjustable Pressure Limit**
Safeguard downstream equipment
- Large Convoluted Diaphragm**
Smooth pressure changes
- Standard Relief Valve**
Diaphragm and gauge protection
- Chrome-Plated Forged Brass Body**
Economical high purity design
- High Flow Capacity**
Supply multiple user locations
- Pressure Ranges 0-15 to 0-200 PSIG (0-1 to 0-14 BAR)**
Broad range of applications

Materials

- Body**
Chrome-plated forged brass
- Bonnet**
Chrome-plated die-cast zinc
- Seat**
PTFE (first stage)
PTFE (second stage)
- Filter**
10-micron sintered bronze
- Diaphragm**
316L stainless steel
- Internal Seals**
PTFE

Specifications

- Maximum Inlet Pressure**
3000 PSIG (210 BAR)
3500 PSIG (240 BAR) optional
4500 PSIG (310 BAR) optional
- Temperature Range**
-40°F to 140°F (-40°C to 60°C)
- Gauges**
2 1/2" (68mm) diameter chrome-plated brass
- Ports**
1/4" FPT
- Helium Leak Integrity**
1 x 10⁻⁸ scc/sec
- Cv**
0.28
See page 206 for flow curves
- Weight (212 2331-580)**
5.1 lbs. (2.3 kg)

CRN 0H5216.5R1

200 Series Regulators



Installation Dimensions

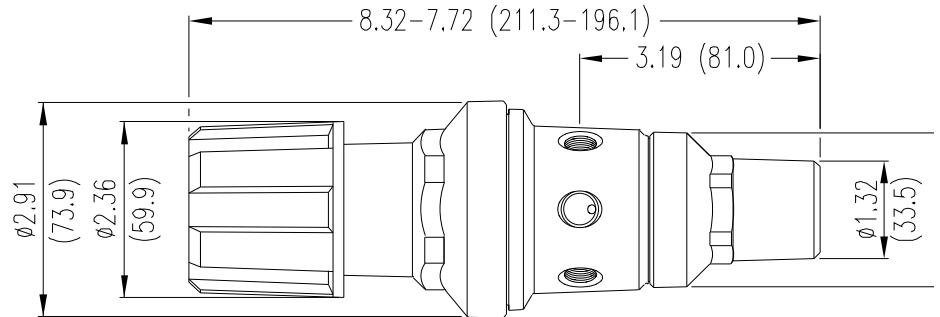
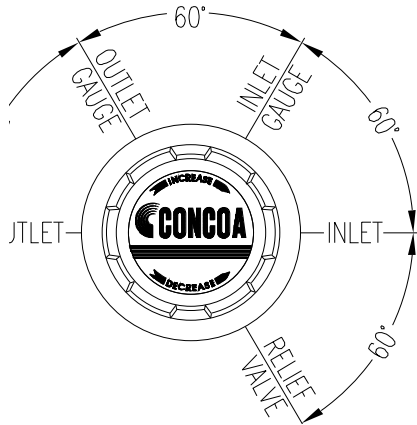

Ordering Information

212	A	B	C	D	-CON	Options	
Series 212	Outlet Pressure	Outlet Gauge	Inlet Gauge	Outlet Assemblies	Assembly Gauges	Inlet Connections	Installed Options
	1: 0-15 PSIG (0-1 BAR)	0-30 PSIG/ 0-2 BAR	0: None	0: 1/4" FPT port	0: Bare body	000: 1/4" FPT	B: Protocol alarm station with pressure switch gauges
	2: 0-40 PSIG (0-3 BAR)	0-60 PSIG/ 0-4 BAR	3: 0-4000 PSIG/ 0-275 BAR	1: 1/4" MPT	1: Standard assembly (PSIG/kPa gauges)	TF2: 1/8" tube	C: Protocol switchover station
	3: 0-120 PSIG (0-8 BAR)	0-200 PSIG/ 0-14 BAR	5: 0-1000 PSIG/ 0-70 BAR	2: 1/4" tube fitting	2: Standard assembly (BAR/PSIG gauges)	TF4: 1/4" tube	E: Protocol alarm station with intrinsically safe transducer for hazardous environments
	4: 0-200 PSIG (0-14 BAR)	0-400 PSIG/ 0-27 BAR	6: 0-400 PSIG/ 0-27 BAR	3: Diaphragm valve 1/4" tube fitting		TF6: 3/8" tube	H: Protocol switchover alarm station with pressure switch gauges
	5: 0-15 PSIG (0-1 BAR)*	0-30 PSIG/ 0-2 BAR with redline for acetylene use	8: 0-6000 PSIG/ 0-415 BAR*	4: Diaphragm valve 1/4" MPT		M06: 6mm tube	J: Protocol alarm station with standard transducer for non hazardous environments
	* Not available with 4500 PSIG (310 BAR) Max Inlet		9: 0-600 PSIG/ 0-42 BAR	5: Needle valve 1/4" MPT		CGA DIN 477 BS 341 and others available	K: Protocol switchover alarm station with standard transducer for non hazardous environments
			G: 0-4000 PSIG/ 0-275 BAR†	6: 1/8" tube fitting			M: Protocol station
			*Max inlet 4500 PSIG (310 BAR) with PCTFE seat CAPSULE®	7: 3/8" tube fitting			Q: Protocol purge station
			†Maximum inlet pressure 3500 (240 BAR) with PCTFE seat CAPSULE	8: Diaphragm valve 1/8" tube fitting			T: Tee purge
				9: Diaphragm valve 1/4" FPT			X: Protocol switchover alarm station with intrinsically safe transducer for hazardous environments
				A: 3/8" BSP RH fitting			
				B: Diaphragm valve 3/8" tube fitting			
				C: 3/8" BSP LG fitting			
				D: 6mm brass hose barb			
				G: 1/8" stainless steel tube fitting			
				H: 1/4" stainless steel tube fitting			
				M: 6mm tube fitting			
				S: Diaphragm valve 6mm tube fitting			

REGULATORS



Regulator Flow Curves

Flow Curves for 212 Series

