

327 SERIES REGULATORS



The 327 Series single stage regulators provide secondary pressure control of non-corrosive, liquefied, or high purity (up to grade 5.5) gases. Unlike most pipeline equipment, the regulator is rated to full cylinder pressure, making it ideal for point-of-use pressure control in high purity gas distribution systems. While the 327 Series regulator may be used with mildly reactive gases, it is not for use with toxic or highly corrosive gases.

Typical Applications

- Bulk Gas Distribution Systems
- Gas and Liquid Chromatography
- High Purity Carrier Gases
- Zero, Span, and Calibration Gases
- High Purity Chamber Pressurization
- Liquefied Hydrocarbon Gas Control



3273031-01-M1L shown

Features

- CAPSULE® Seat** increases serviceability and life
- 316L Stainless Steel Diaphragm** prevents inboard diffusion
- Low Wetted Surface Area** minimizes purge requirements
- Field-Adjustable Pressure Limit** safeguards downstream equipment
- Convuluted Diaphragm** provides smooth pressure changes
- Compact Design** permits easy transport and system integration
- Rear Panel-Mount** allows easy installation
- Pressure Ranges 0-15 to 0-200 PSIG (0-1 to 0-14 BAR)** facilitates a range of applications

Materials and Specifications

- Maximum Inlet Pressure (bare body):** 3000 PSIG (210 BAR)
- Body:** 316L stainless steel barstock
- Bonnet:** Chrome-plated, die-cast zinc
- Gauges:** 2 in (50 mm) diameter stainless steel internals with plated case
- Seat:** PTFE
- Filter:** 10-micron 316 stainless steel mesh
- Temperature Range:** -40°F to 140°F (-40°C to 60°C)
- Diaphragm:** 316L stainless steel
- Cv:** 0.1 See flow curves attached
- Helium Leak Integrity:** 1×10^{-8} scc/sec
- Internal Seals:** PTFE
- Ports (bare body):** 1/4 in FNPT
- Weight (327 1031-M1L):** 2.9 lbs. (1.3 kg)
- Conformances:** Cleanliness meets or exceeds CGA G-4.1; PED 2014/68/EU; ANSI/ASME B40.1; CRN OH5216

327 SERIES REGULATORS



Installation Dimensions

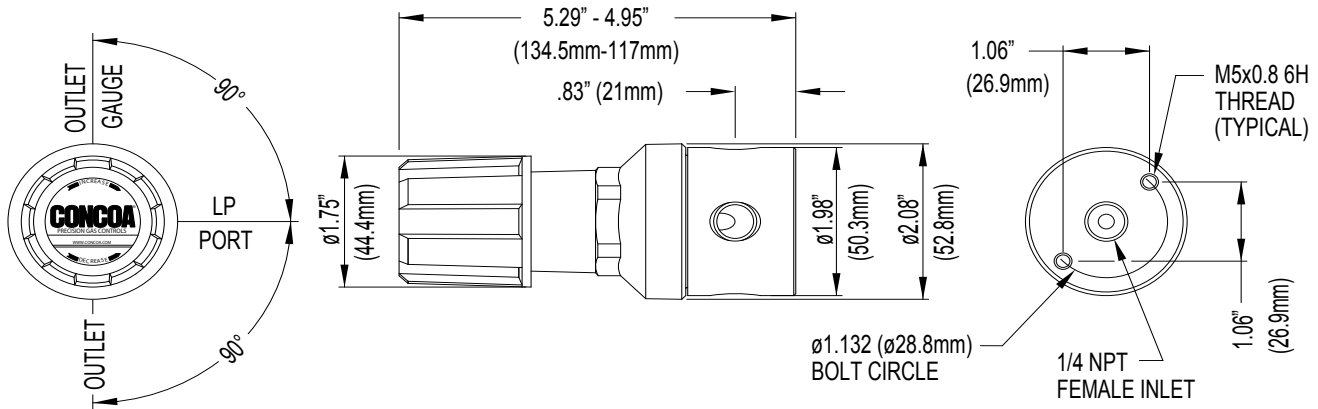

Ordering Information

327	A	B	C	D	-CON	Options	
Series 327	Outlet Pressure	Outlet Gauge	Inlet Gauge	Outlet Assemblies	Assembly Gauges	Inlet Connections	Installed Options
	1: 0-15 PSIG (0-1 BAR)	0-30 PSIG/ 0-2 BAR	0: None	0: 1/4 in FPT port	0: Bare body	000: 1/4 in FPT	None
	2: 0-30 PSIG (0-2 BAR)	0-60 PSIG/ 0-4 BAR		1: 1/4 in MPT	1: Standard assembly (PSIG/kPa gauges)	TF2: 1/8 in tube	
	3: 0-50 PSIG (0-3.5 BAR)	0-100 PSIG/ 0-7 BAR		2: 1/4 in tube fitting	2: Standard assembly (BAR/PSIG gauges)	TF4: 1/4 in tube	
	4: 0-150 PSIG (0-10 BAR)	0-200 PSIG/ 0-14 BAR		3: Diaphragm valve 1/4 in tube fitting		TF6: 3/8 in tube	
	5: 0-100 PSIG (0-7 BAR)	0-200 PSIG/ 0-14 BAR		4: Diaphragm valve 1/4 in MPT		M06: 6 mm tube	
	6: 0-200 PSIG (0-14 BAR)	0-400 PSIG/ 0-27 BAR		5: Needle valve 1/4 in MPT		CGA DIN 477 BS 341 and others available	
				6: 1/8 in tube fitting			
				7: 3/8 in tube fitting			
				8: Diaphragm valve 1/8 in tube fitting			
				9: Diaphragm valve 1/4 in FPT			
				M: 6 mm tube fitting			
				S: Diaphragm valve 6 mm tube fitting			

Related Options

Part No.	Description
835 0204	Rear panel mount kit
476 0002	Helium leak certification



Regulator Flow Curves

Flow Curves for 302, 304, 305, 307, 322, 324, 327, 401, 402, 408, 420, 422, 426, 427, 428, 429 Series

