

332 SERIES REGULATORS



The 332 Series dual stage regulators provide primary pressure control for high purity, inert gases (up to grade 5.5), including mildly reactive gases, but not toxic or highly corrosive gases. Two stages of pressure regulation minimize pressure variation arising from inlet pressure changes, such as the depletion of the supply cylinder, making the 332 series regulator ideal for applications requiring constant pressure control and delivery regardless of supply pressure variations.

Typical Applications

- EPA Protocol Gases
- Gas and Liquid Chromatography
- High Purity Carrier Gases
- Zero, Span, and Calibration Gases
- High Purity Chamber Pressurization



3323331-01-580 shown

Features

CAPSULE® Seat increases serviceability and life

316L Stainless Steel Diaphragm prevents inboard diffusion

Low Wetted Surface Area minimizes purge requirements

Field-Adjustable Pressure Limit safeguards downstream equipment

Convolute Diaphragm provides smooth pressure changes

Compact Design permits easy transport and system integration

Pressure Ranges 0-15 to 0-250 PSIG (0-1 to 0-17 BAR) facilitates a range of applications

Materials and Specifications

Maximum Inlet Pressure (bare body): 3000 PSIG (210 BAR); 4500 PSIG (310 BAR) optional

Body: 316L stainless steel barstock

Bonnet: Chrome-plated, die-cast zinc

Gauges: 2 in (50 mm) diameter stainless steel internals with plated case

Seats: PCTFE (first stage); PTFE (second stage)

Filter: 10-micron 316 stainless steel mesh

Temperature Range: -40°F to 140°F (-40°C to 60°C)

Diaphragm: 316L stainless steel

Cv: 0.1 See flow curves attached

Helium Leak Integrity: 1×10^{-8} scc/sec

Internal Seals: PTFE

Ports (bare body): 1/4 in FNPT

Weight (332 2331-580): 4.2 lbs. (1.9 kg)

Conformances: Cleanliness meets or exceeds CGA G-4.1; PED 2014/68/EU; ANSI/ASME B40.1; CRN OH5216

332 SERIES REGULATORS



Installation Dimensions

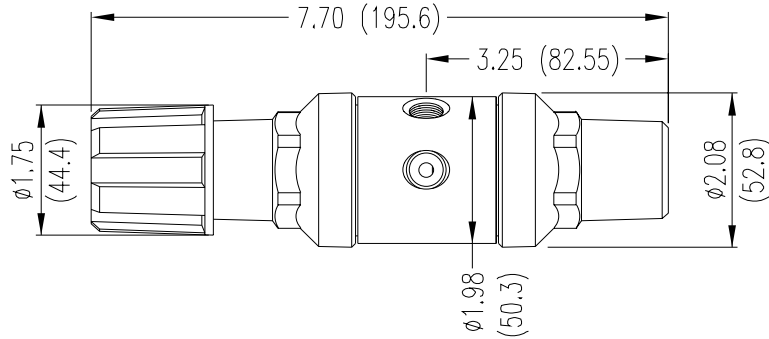
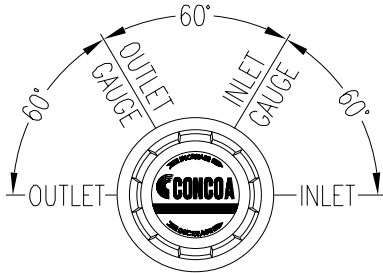

Ordering Information

332	A	B	C	D	-CON	Options	
Series 332	Outlet Pressure	Outlet Gauge	Inlet Gauge	Outlet Assemblies	Assembly Gauges	Inlet Connections	Installed Options
	1: 0-15 PSIG (0-1 BAR)	30 in -0-30 PSIG/ -1-0-2 BAR	0: None	0: 1/4 in FPT port	0: Bare body	000: 1/4 in FPT	B: Protocol alarm station with pressure switch gauges
	2: 0-50 PSIG (0-3.5 BAR)	30 in -0-100 PSIG/ -1-0-7 BAR	3: 0-4000 PSIG/ 0-278 BAR	1: 1/4 in MPT	1: Standard assembly (PSIG/kPa gauges)	TF2: 1/8 in tube	C: Protocol switchover station
	3: 0-100 PSIG (0-7 BAR)	30 in -0-200 PSIG/ -1-0-14 BAR	5: 0-1000 PSIG/ 0-70 BAR	2: 1/4 in tube fitting	2: Standard assembly (BAR/PSIG gauges)	TF4: 1/4 in tube	E: Protocol alarm station with intrinsically safe transducer for hazardous environments
	4: 0-250 PSIG (0-17 BAR)	0-400 PSIG/ 0-27 BAR	6: 0-300 PSIG/ 0-21 BAR	3: Diaphragm valve 1/4 in tube fitting		TF6: 3/8 in tube	H: Protocol switchover alarm station with pressure switch gauges
	7: 0-150 PSIG (0-10 BAR)	30 in -0-200 PSIG/ -1-0-14 BAR	7: 0-400 PSIG/ 0-27 BAR	4: Diaphragm valve 1/4 in MPT		M06: 6 mm tube	J: Protocol alarm station with standard transducer for non-hazardous environments
			8: 0-6000 PSIG/ 0-415 BAR*	5: Needle valve 1/4 in MPT		CGA DIN 477 BS 341 and others available	K: Protocol switchover alarm station with standard transducer for non-hazardous environments
			G: 0-4000 PSIG/ 0-275 BAR†	6: 1/8 in tube fitting			M: Protocol station
			Maximum inlet pressure 4500 PSIG (310 BAR) with PCTFE Seat CAPSULE®	7: 3/8 in tube fitting			Q: Protocol purge station
			†Maximum inlet pressure 3500 PSIG (240 BAR) with PCTFE seat CAPSULE	8: Diaphragm valve 1/8 in tube fitting			T: Tee purge*
				9: Diaphragm valve 1/4 in FPT			X: Protocol switchover alarm station with intrinsically safe transducer for hazardous environments
				M: 6 mm tube fitting			*Not available with 4500 PSIG (310 BAR) max inlet pressure
				S: Diaphragm valve 6 mm tube fitting			

Flow Curves for 312, 315, 332, 411, 412, 414, 415, 430, 432 Series

