

SWITCHOVER & MANIFOLD FLOOR STANDS



CONCOA Manifold and Switchover Floor Stands provide a convenient method to mount manifolds and switchovers where a permanent structure is unavailable. Switchover floor mount stations are designed to mount a 526 or 527 Series switchover system and two cylinders in areas where wall mounting is inconvenient. The switchover stations are pre-drilled for easy mounting and include cylinder brackets with straps to secure the cylinders in place, providing secure gas cylinder storage and easy-to-reach control mounted panels for gas distribution. Models 518 1625 and 518 1725 offer a unique header plate to mount single cylinder per side switchover configurations. For safety, the switchover station must be secured to a floor or pad. Each manifold and switchover floor stand model comes with the necessary hardware to safely secure compressed gas cylinders that otherwise are unable to support themselves.

Typical Applications

- Medical or Industrial Gas Storage and Use Areas
- Pharmaceutical and Forensic Gas Industry
- Laboratory, Research, or Process Plants
- Modified Atmosphere Packaging (MAP)
- Manufacturing Systems



5181725-01-001 shown with 526 switchovers (sold separately)

5181610 shown

Features

- **Powder-Coated Painted Steel Construction** ensures chemical resistance and long service life
- **Steel Frame and Strap Design** restrains various sized cylinders safely and securely
- **Bumper Guard Edging** provides extra grip and protects cylinders from damage

Materials and Specifications

- **Stand Material:** Powder-coated steel
- **Cylinder Bracket Material:** 11-gauge, hot rolled steel
- **Strap Material:** 1.5 in x 54 in polypropylene with plated spring buckle

SWITCHOVER & MANIFOLD FLOOR STANDS



Installation Dimensions

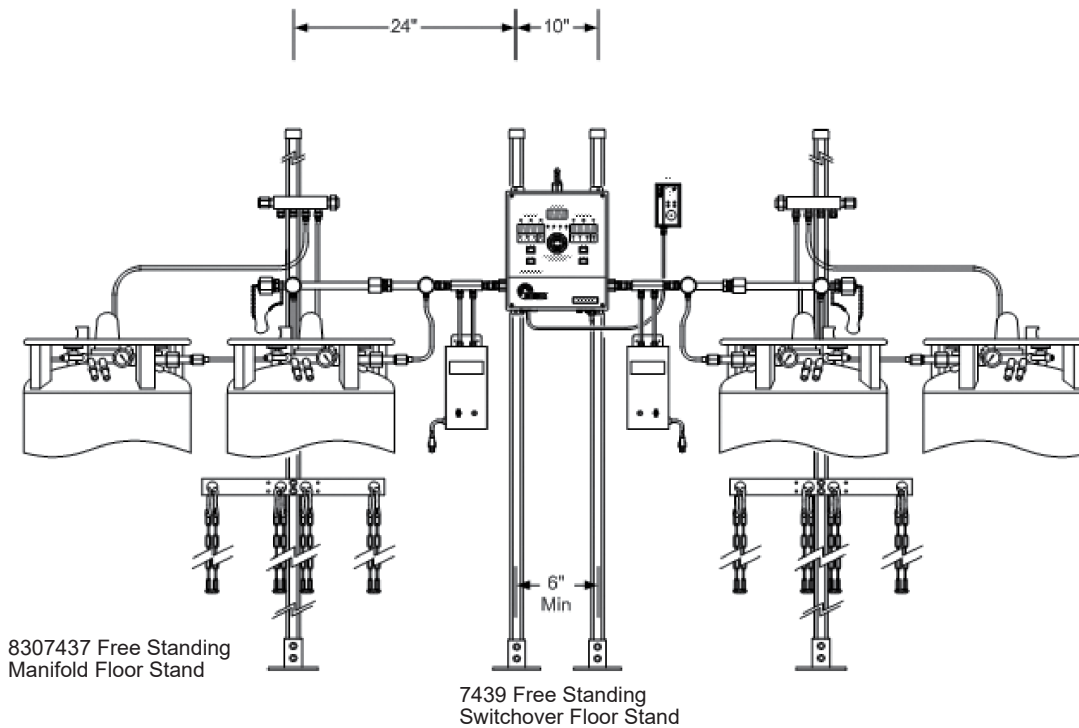

Ordering Information

Part No.	Description	Dimensions (W x D x H)
518 1610	Cylinder Floor Mount Stand Holds 1-Cylinder in the Vertical Position, with Top and Bottom Tiedown Straps	18 in x 13.75 in x 72 in (457 mm x 349 mm x 1829 mm)
518 1624	Single Switchover Floor Stand with Storage for Two 12 in Cylinders, with Top and Bottom Tiedown Straps	28 in x 10.5 in x 72 in (711 mm x 267 mm x 1829 mm)
518 1625	Single Switchover Floor Stand with Storage for Two 12 in Cylinders, with Top Tiedown Straps	28 in x 10.5 in x 72 in (711 mm x 267 mm x 1829 mm)
518 1645	Single Switchover Floor Mount Process Station for 4-Cylinder Storage, with Top and Bottom Tiedown Straps	52 in x 14 in x 72 in (1321 mm x 356 mm x 1829 mm)
518 1725-01-001	6-Cylinder Floor Mount Process Station with Back-to-Back Configuration of 3-Cylinders per Side	44 in x 23 in x 72 in (1118 mm x 584 mm x 1829 mm)
830 7437	Manifold Extension Floor Stand Designed to Provide Support Every 24 Inches	Base 6 in x 6 in x 84 in height (152 mm x 152 mm x 2134 mm)
830 7439	AutoSwitch Floor Stand Designed to Provide Support with Dual Vertical Posts	Base 12 in x 12 in min. x 84 in height (305 mm x 305 mm x 2134 mm)