

# SWITCHOVER & MANIFOLD FLOOR STANDS



CONCOA Floor Stands provide convenient and secure mounting for gas supply switchovers and gas cylinder manifolds. Switchover floor mount stations are designed to mount a 526 or 527 Series pressure regulator switchover and two cylinders in areas where wall mounting is inconvenient. The switchover stations are pre-drilled for easy mounting and include cylinder brackets with straps to secure the cylinders in place, providing secure gas cylinder storage and easy-to-reach control mounted panels for gas manifold systems. Models 518 1625 and 518 1725 offer a unique header plate to mount single cylinder per side switchover configurations. For safety, the gas cylinder floor stand must be secured to the floor or to a pad. Each cylinder floor stand model comes with the necessary hardware to safely secure the compressed gas cylinders.

## Typical Applications

- Medical or Industrial Gas Storage and Use Areas
- Pharmaceutical and Forensic Gas Industry
- Laboratory, Research, or Process Plants
- Modified Atmosphere Packaging (MAP)
- Manufacturing Systems



*518 1725-01-001 shown with 526 switchovers (sold separately)*

*518 1610 shown*

## Features

**Powder-Coated Painted Steel Construction** ensures chemical resistance and long service life

**Steel Frame and Strap Design** restrains various sized cylinders safely and securely

**Bumper Guard Edging** provides extra grip and protects cylinders from damage

## Materials and Specifications

**Stand Material:** Powder-coated steel

**Cylinder Bracket Material:** 11-gauge, hot rolled steel

**Strap Material:** 1.5 in x 54 in polypropylene with plated spring buckle

# SWITCHOVER & MANIFOLD FLOOR STANDS



## Installation Dimensions

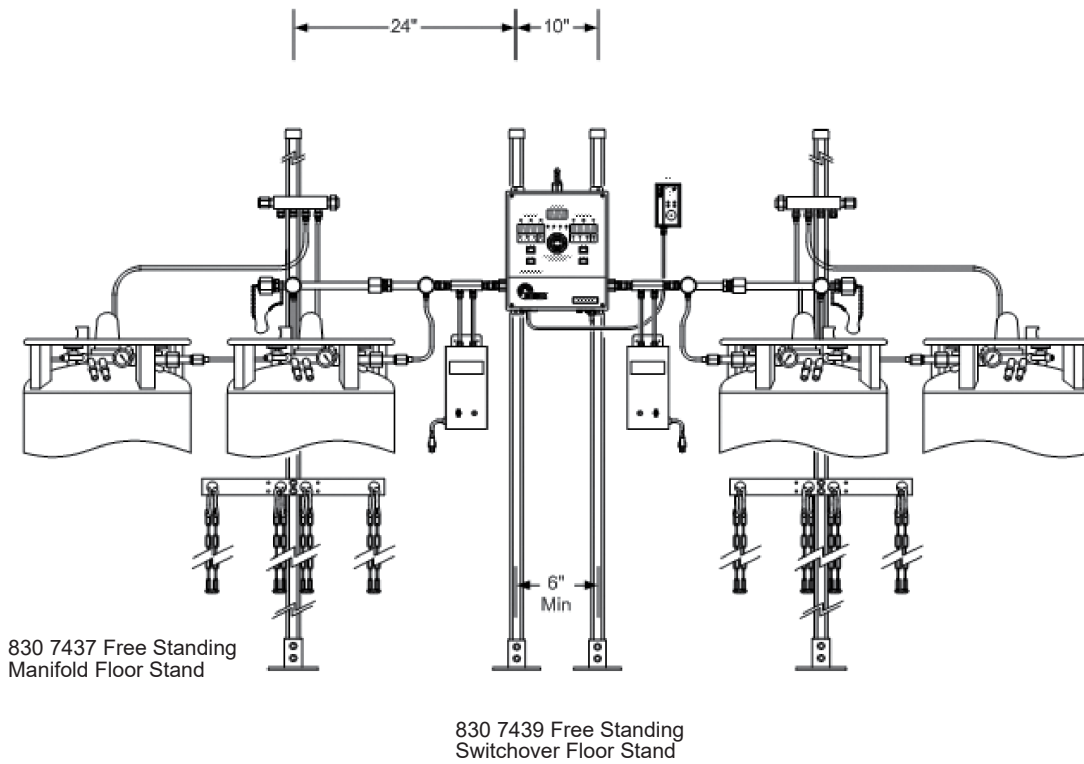

## Ordering Information

Part No.	Description	Dimensions (W x D x H)
518 1610	Cylinder Floor Mount Holds 1-Cylinder in the Vertical Position with Top and Bottom Tiedown Straps	18 in x 13.75 in x 72 in (457 mm x 349 mm x 1829 mm)
518 1625	Single Switchover Floor Mount with Storage for Two 12 in Cylinders with Top Tiedown Straps	28 in x 10.5 in x 72 in (711 mm x 267 mm x 1829 mm)
518 1645	Single Switchover Floor Mount Station for 4-Cylinder Storage with Top and Bottom Tiedown Straps	52 in x 14 in x 72 in (1321 mm x 356 mm x 1829 mm)
518 1725-01-001	6-Cylinder Floor Mount Process Station. Back-to-Back Configuration of 3-Cylinders per Side	44 in x 23 in x 72 in (1118 mm x 584 mm x 1829 mm)
830 7437	Manifold Extension Floor Stand Designed to Provide Support Every 24 Inches	Base 6 in x 6 in x 84 in height (152 mm x 152 mm x 2134 mm)
830 7439	AutoSwitch Floor Stand Designed to Provide Support with Dual Vertical Posts	Base 12 in x 12 in min. x 84 in height (305 mm x 305 mm x 2134 mm)